

Model Name: PE4H
Product Name: PCI-E 16X to Excard adapter
Ver 1.0a

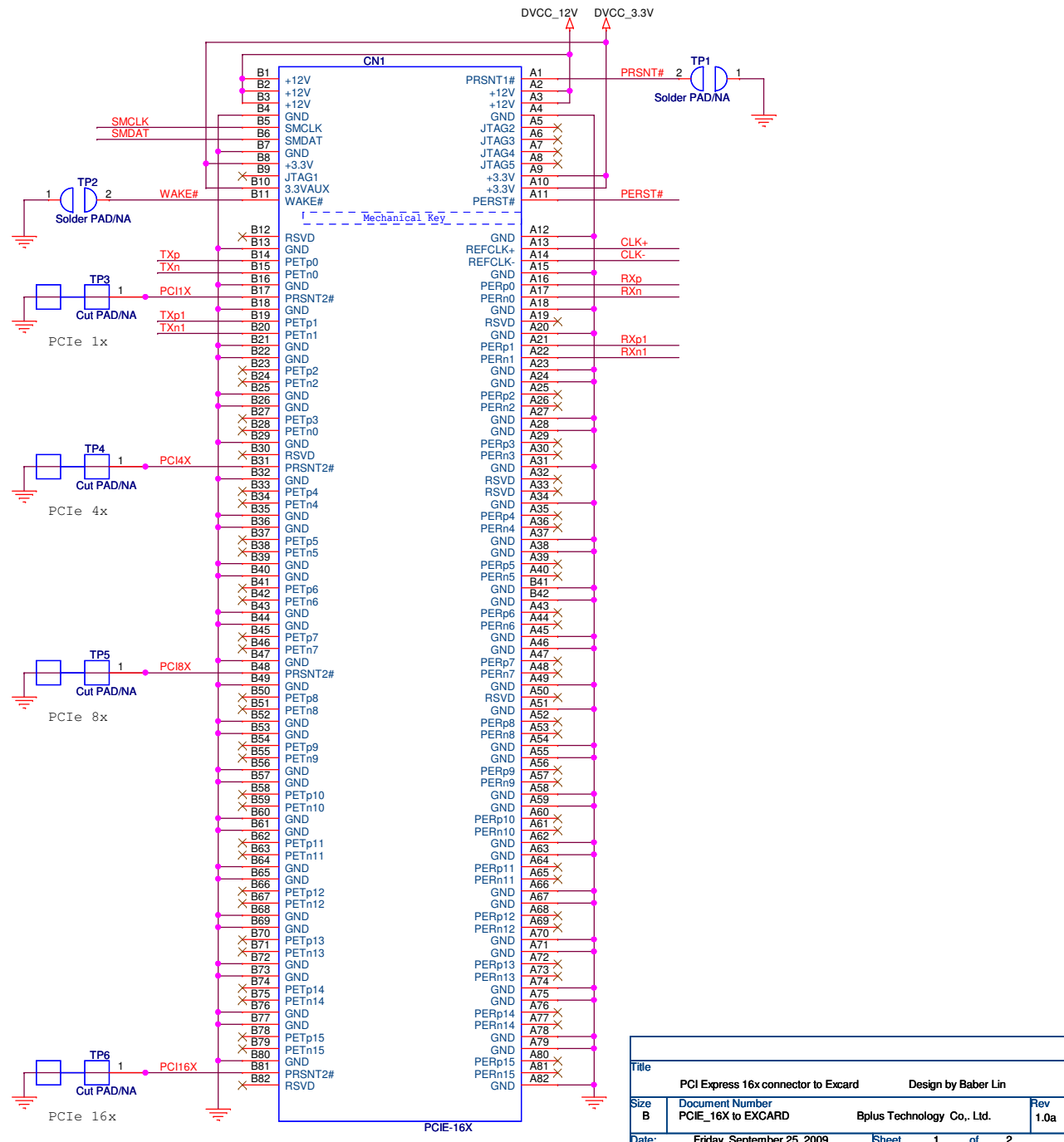
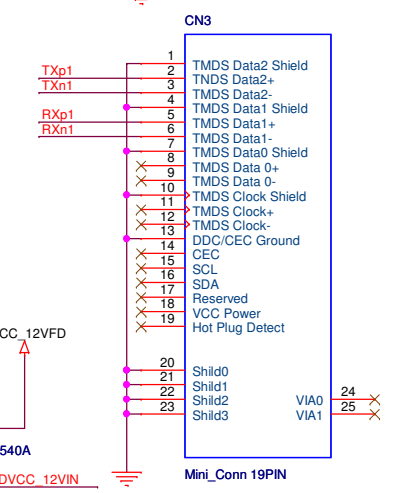
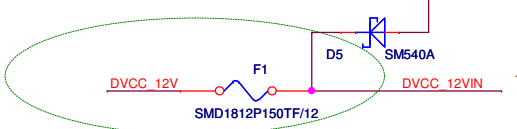
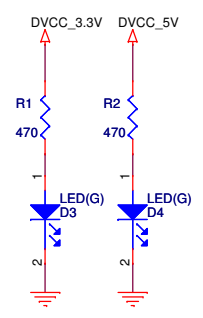
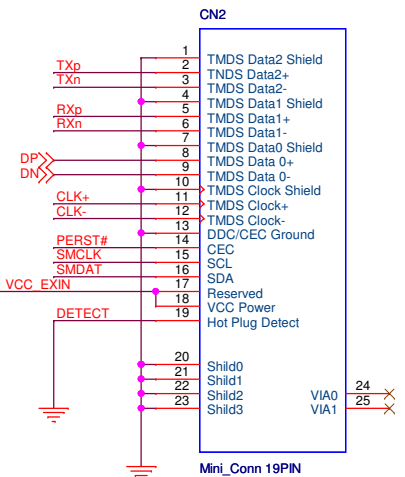
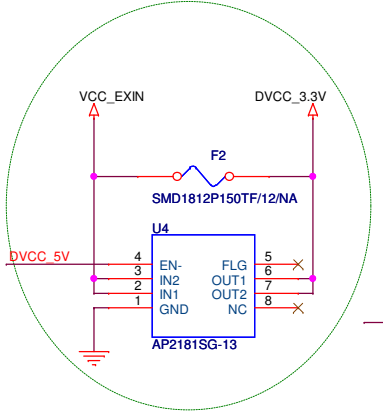

Title		PCI Express 16x connector to Excard		Design by Baber Lin	
Size	Document Number	Bplus Technology Co., Ltd.		Rev	1.0a
B	PCIE_16X to EXCARD				
Date:	Friday, September 25, 2009	Sheet	1	of	2

Product Name: PCI-E 16X to Excard adapter

Ver 1.0a

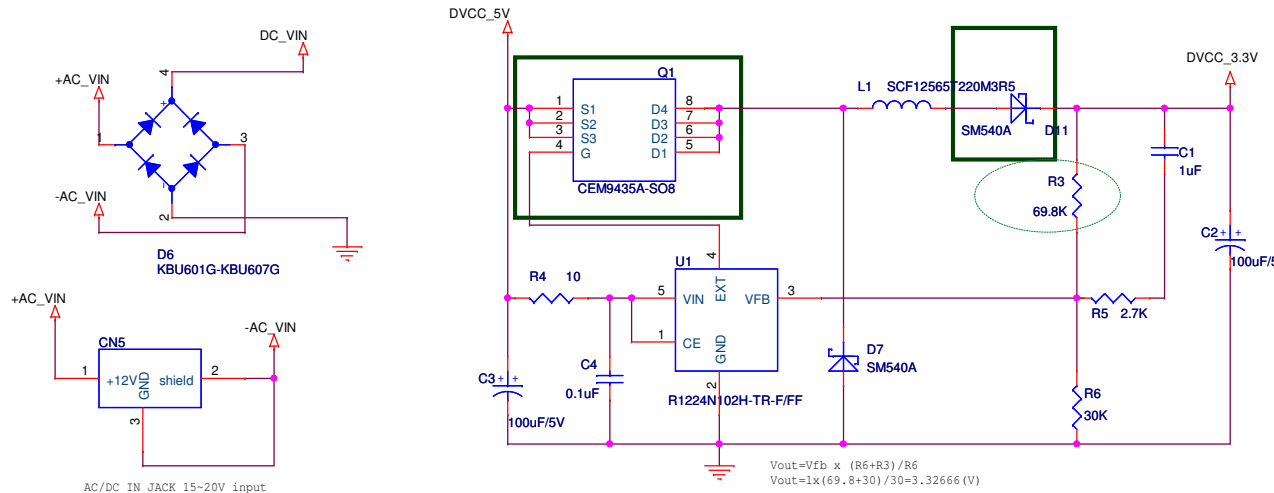
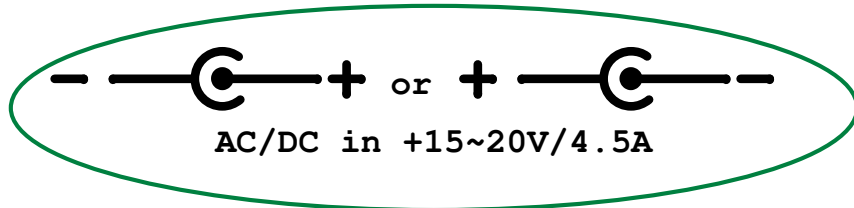

5V to 3.3V/3A DCDC circuit diagram

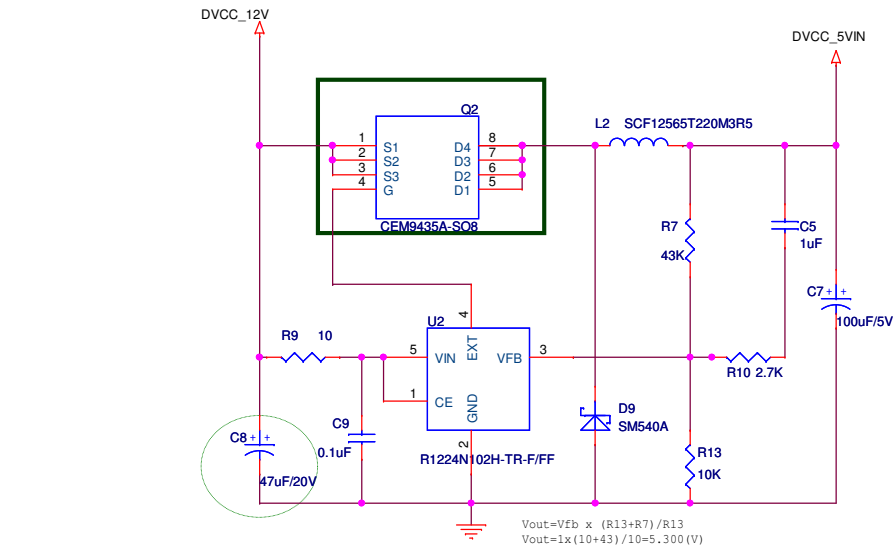

12V to 5V/3A DCDC circuit diagram

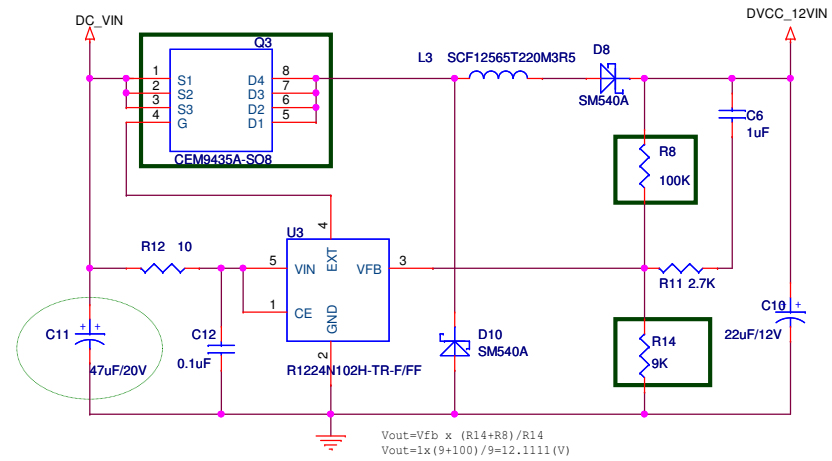

12V~20V to 12V/3A DCDC circuit diagram

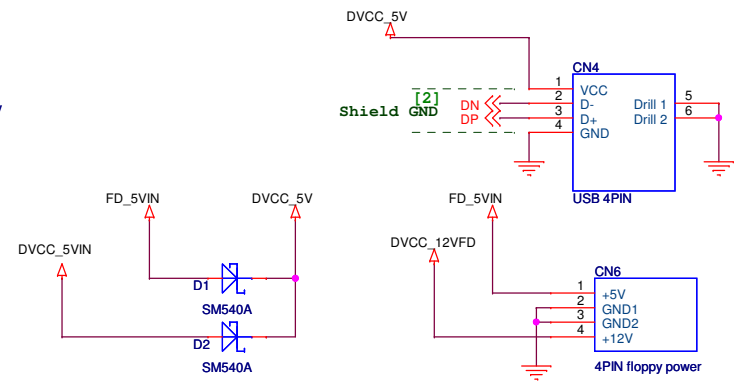

Title			
PCI Express 16x connector to Excard		Design by Mike Mao	
Size	Document Number	Bplus Technology Co., Ltd.	Rev
B	PCIE_16X to EXCARD		1.0a
Date:	Wednesday, September 30, 2009	Sheet	2 of 2