

MiniCard to PCI-E Adapter Ver2.0

Model:MP2

- [1] Impedance control required for CLK+ CLK- PETXP PETXN PERXP PERXN : 100ohm
- [2] Impedance control required for DP DN : 90ohm

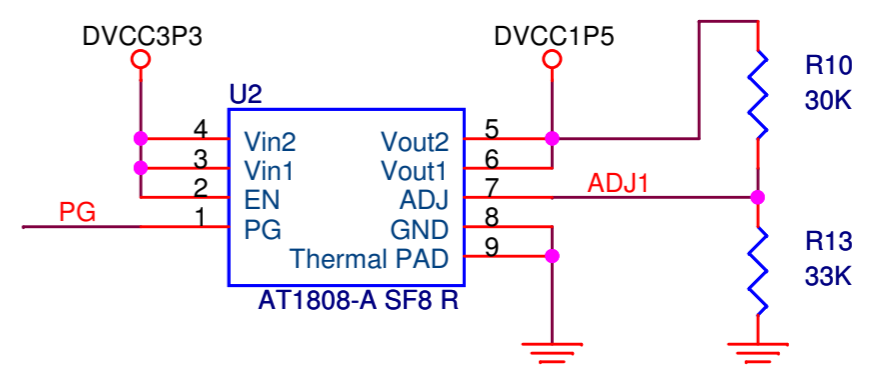
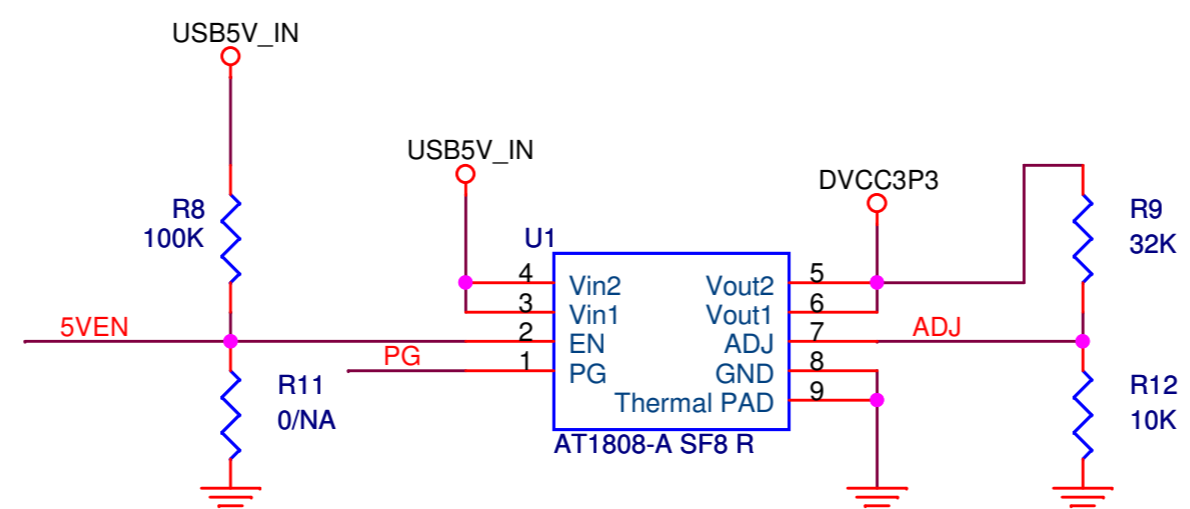
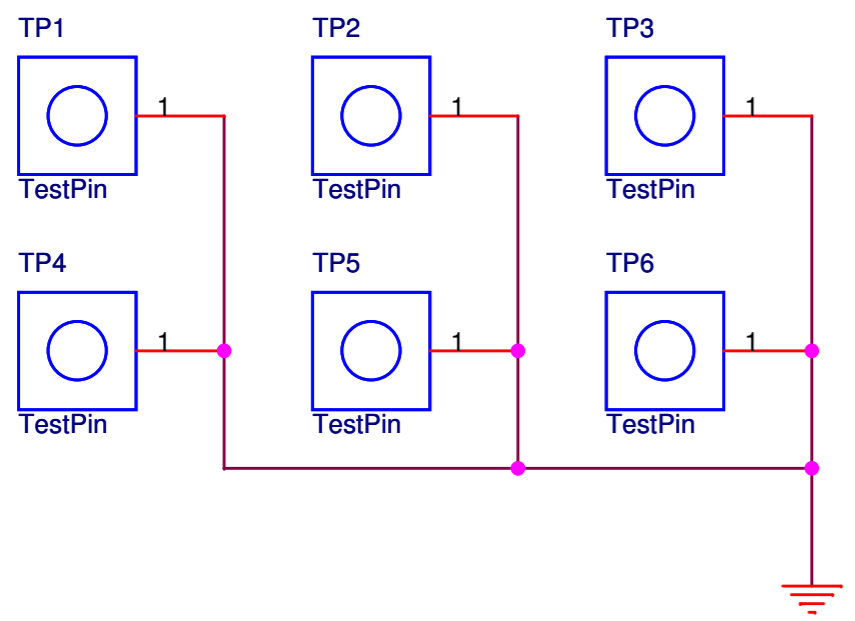
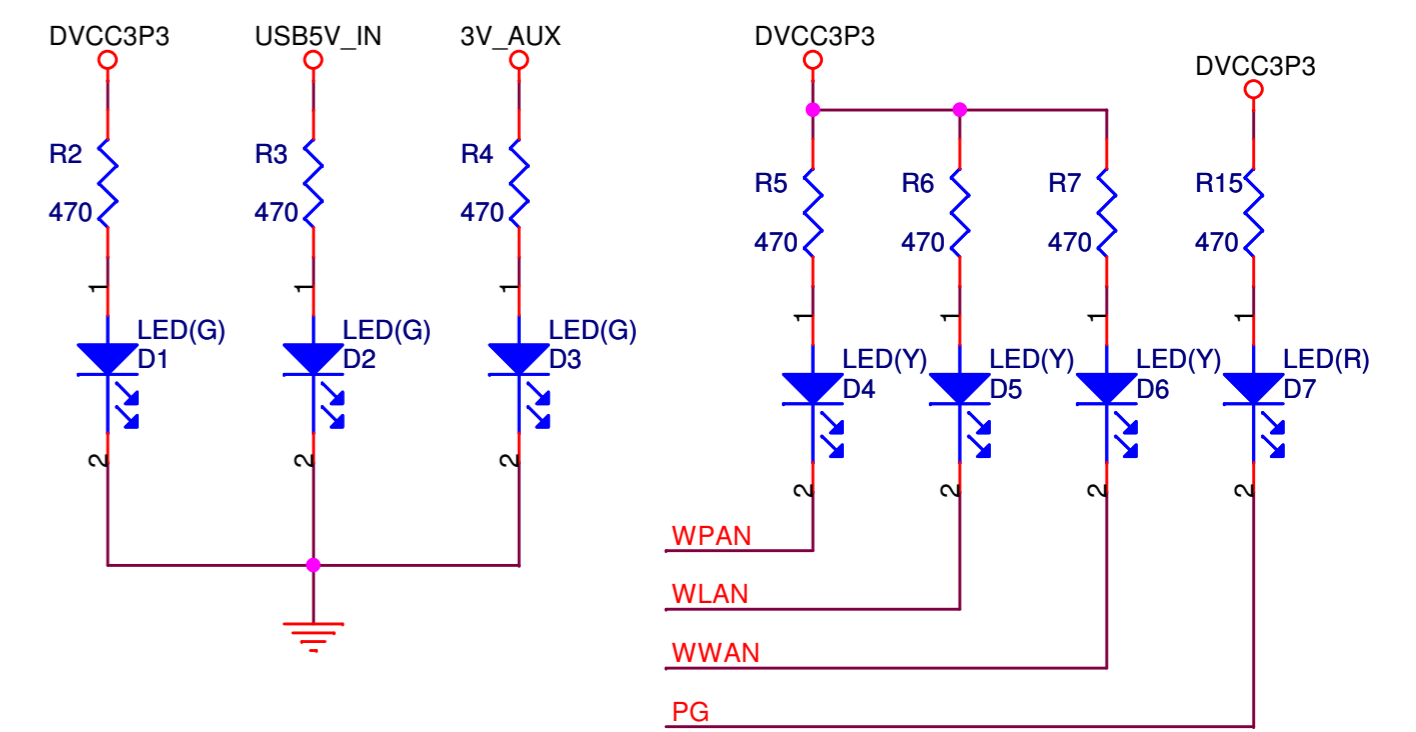
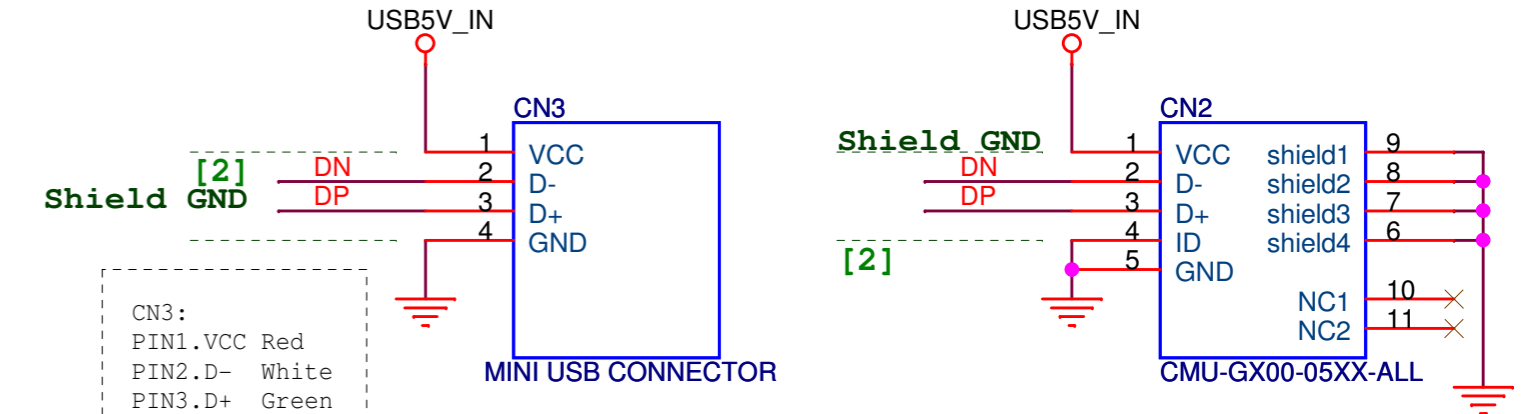
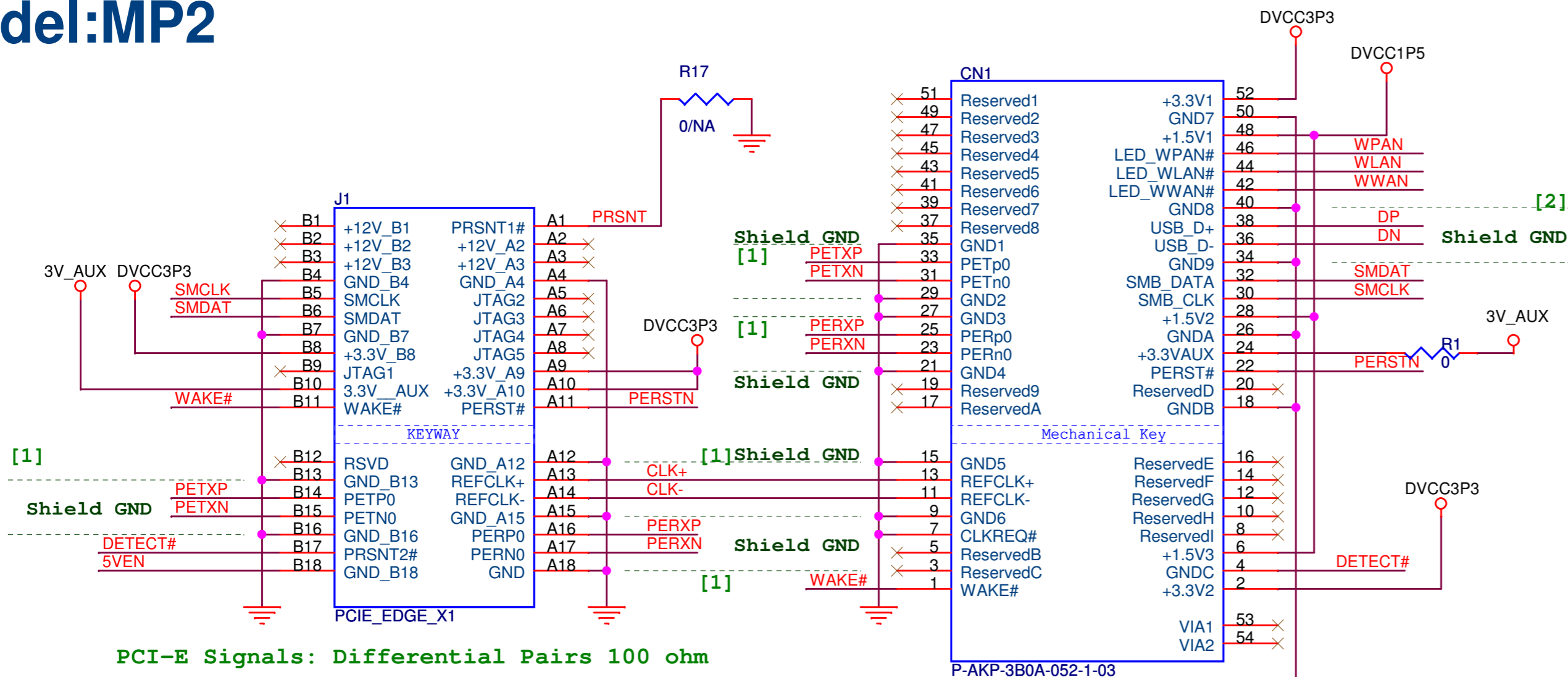

LED	Description
D1	DVCC3P3
D2	USB5V_IN
D3	3V_AUX
D4	WPAN
D5	WLAN
D6	WWAN
D7	POWER_ALARM

$$V_{out} = 0.8 (R9 + R12) / R12$$

$$V_{out} = 0.8 (32K + 10K) / 10K = 3.36V$$

$$V_{out} = 0.8 (R10 + R13) / R13$$

$$V_{out} = 0.8 (30K + 33K) / 33K = 1.527V$$

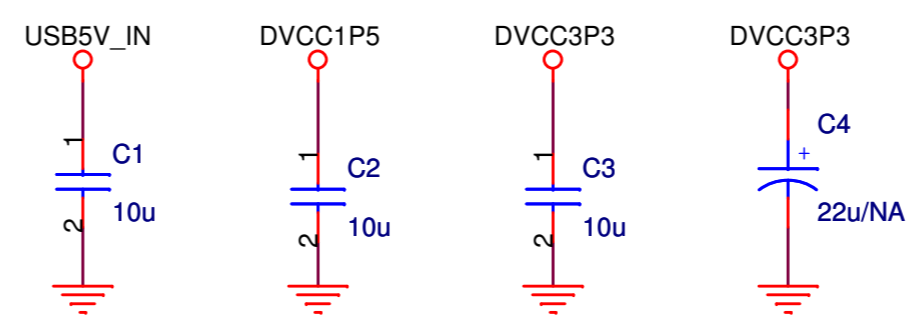
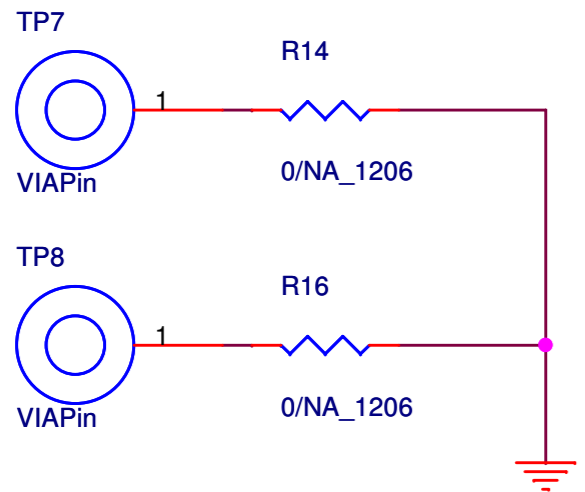

MP2			
Title		Gerry Chen	
MiniCard to PCI-E Adapter Ver2.0			
Size	Document Number	Aeneas Electronics Co., Ltd.	Rev
B	PCI-E Add-in Card		2.0
Date:	Friday, April 10, 2009	Sheet	1 of 1