

Custom PATA/SATA mPCIe to PATA/SATA Adapter Ver1.0a

[1] Impedance control required for CLK+ CLK- PETXP PETXN PERXP PERXN : 100ohm
 [2] Impedance control required for DP DN : 90ohm

Model:MP2S

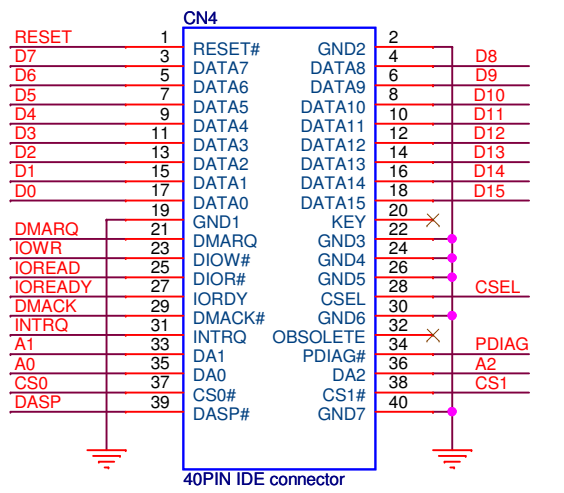
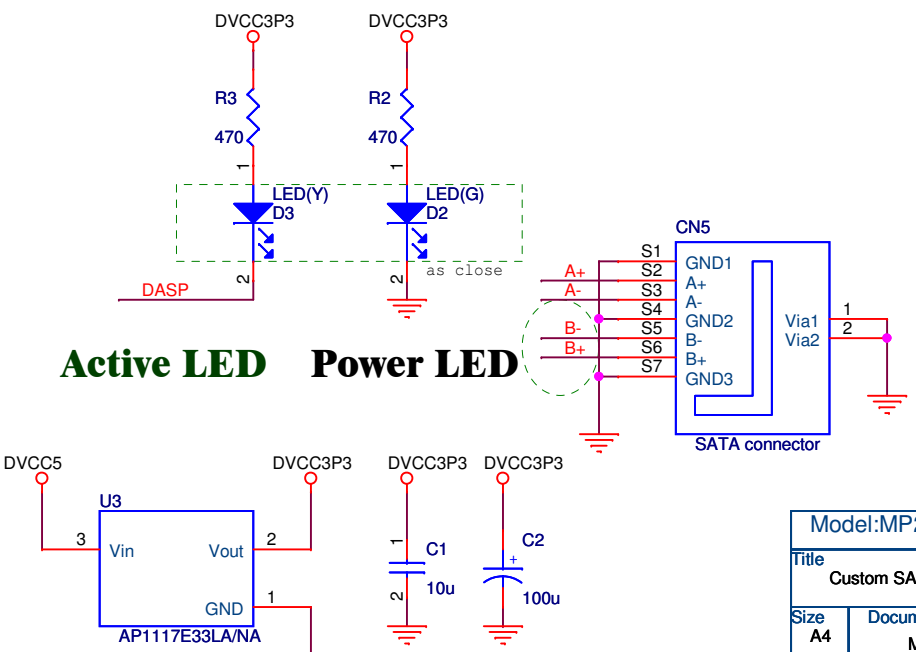
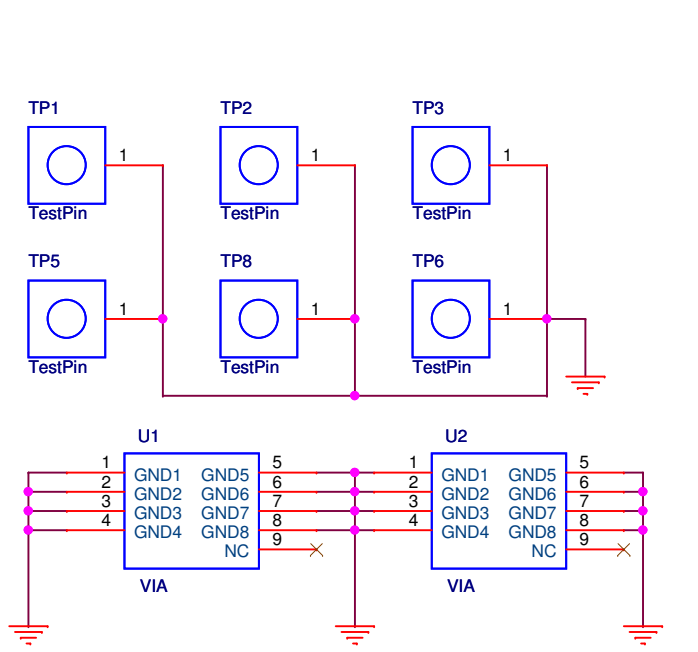
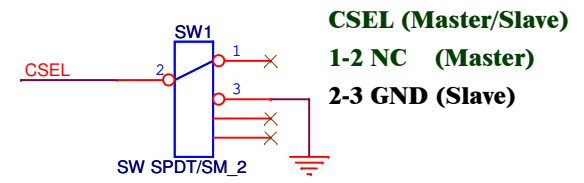
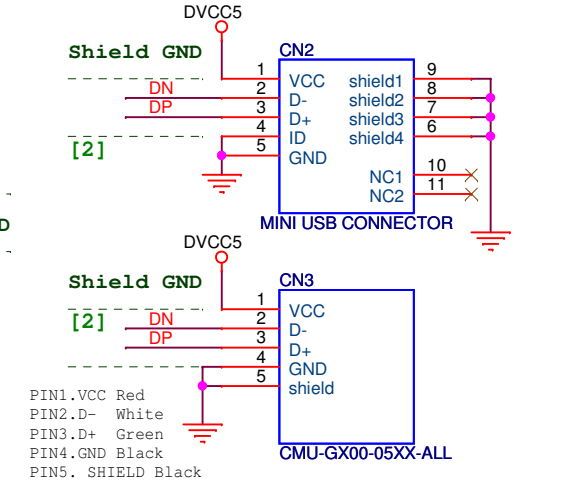
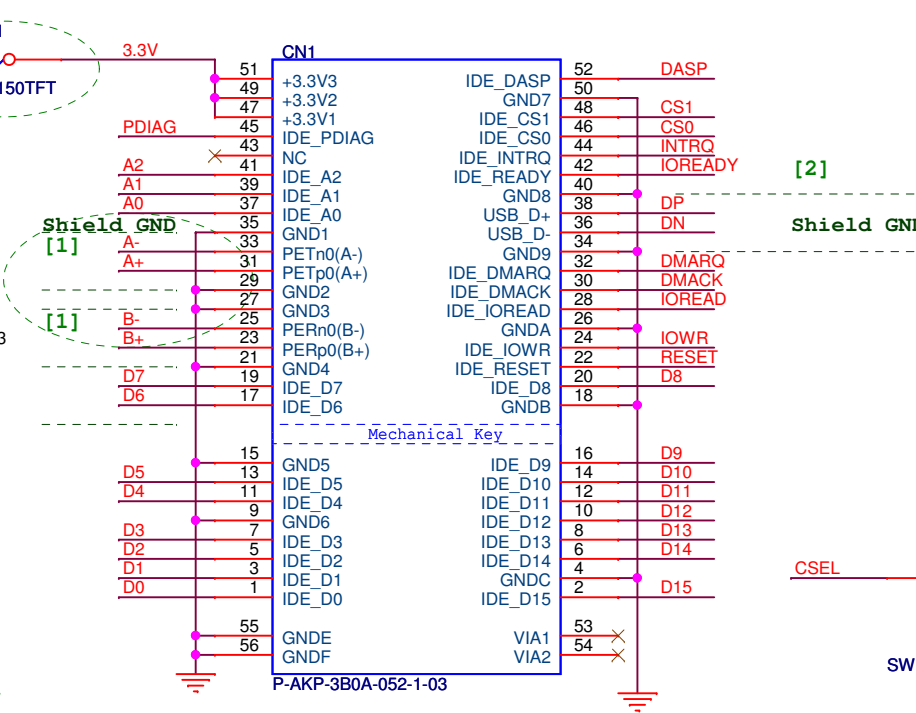
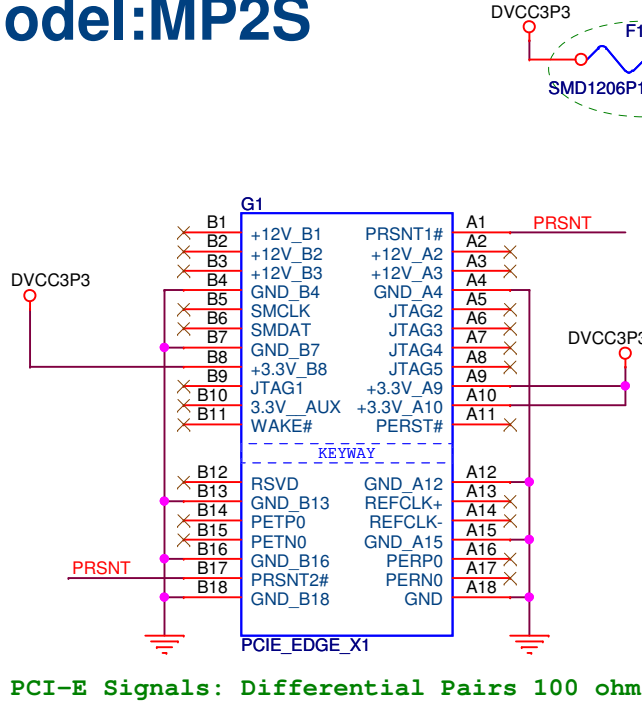

Model:MP2S			
Title		Custom SATA/PATA mPCIe to SATA/PATA Adapter by Gerry Chen	
Size	Document Number	Rev	
A4	MP2S	1.0a	
Date:	Tuesday, September 22, 2009	Sheet	1 of 1