

FEATURES

- Suitable for modem speeds up to V.90 (56 kbps).
- Total Harmonic Distortion rated -88 dB typ. @ 600 Hz, -10 dBm and -82 dB typ. @ 150 Hz, -3 dBm.
- Insertion Loss rated 1.90 dB typ. @ 1000 Hz.
- Complies with IEC60950 Supplementary safety norms.
- Matches 600 Ohm and complex impedance telephone lines.
- Uses minimal external components for impedance matching for pan-European CTR21 lines.
- Reflects 600 Ohms on Primary with 374 Ohms Secondary Load to match 600-ohm lines (external components recommended, but optional).
- Small PCB footprint (20.3 mm x 26.0 mm).
- Low-Profile (12.2 mm).
- Industry-standard pin configuration.

DESCRIPTION

The REMtech Magnetics MIT-4262 is a “Dry” Modem Isolation Transformer suitable for up to V.90 (56 kbps) consumer and internet analog modem applications compliant with Worldwide safety norms.

MIT-4262 can serve as a “drop-in” replacement for MIT-3262 to meet upcoming IEC60950 Supplementary worldwide safety on 600-Ohm lines.

MIT-4262 offers award-winning performance in Conexant-based modem designs at a very competitive price.

PRODUCT COMPLIANCE

- UL / C-UL recognized file number: E171120
- BSI certificate number(s): 8047, 8048
- BAPT certificate of recognition: 1905

NOMENCLATURE (Fig. 1)

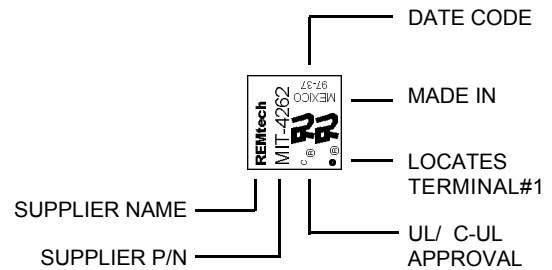

MECHANICAL DIMENSIONS (Fig. 2)

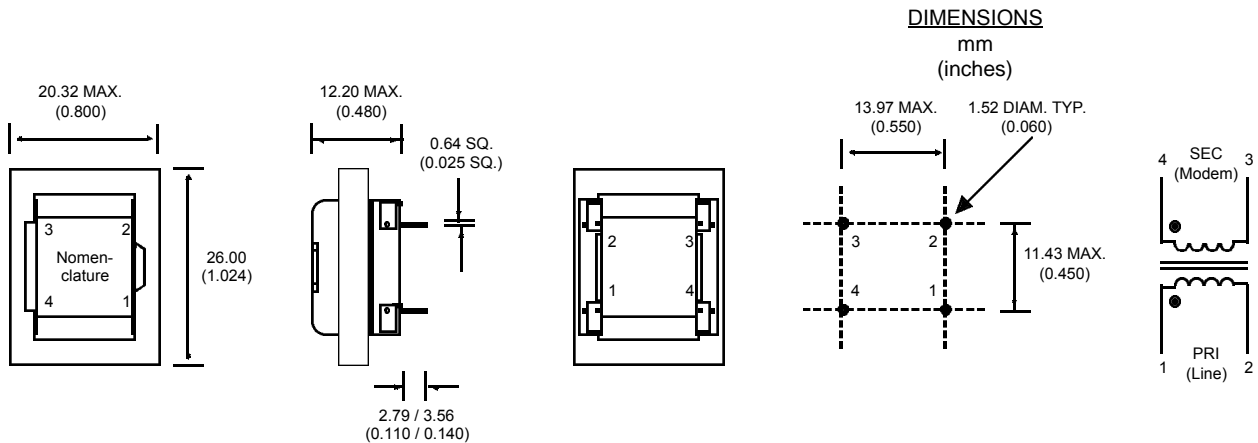

Literature Number: DSA.MIT-4262
© Copyright 2000, REMtech Corporation
All rights reserved. Printed in U.S.A.
9/00

ELECTRICAL PERFORMANCE SPECIFICATIONS

Electrical Performance Specifications (T_A = 25 °C unless otherwise specified)

PARAMETERS	CONDITIONS	MIN	TYP	MAX	UNITS
Impedance	Reflected on Primary With Load on Secondary	-	600	-	Ohms
		-	374	-	Ohms
Total Harmonic Distortion	@ 600 Hz, -10 dBm @ 150 Hz, -3 dBm	-	-88	-82	dB
		-	-82	-75	dB
Insertion Loss	Per IEEE method; @ 1000 Hz	-	1.90	2.25	dB
Return Loss	200 Hz - 4000 Hz Per 600 Ohm Match (Fig. 3) Per CTR21 Pan-Euro Match (Fig. 10)	20	-	-	dB
		22	-	-	dB
Dielectric Breakdown Isolation Production methods applied:	Safety Standard tested 1 Min. HiPot Voltage Duration Trip Leakage Current	1500	-	-	Vrms
		1875	-	-	Vrms
		2	-	-	Sec
		-	-	200	µA
Frequency Response	200 Hz - 4000 Hz	-	±0.25	-	dB
Longitudinal Balance	Per FCC part 68.310 60 Hz - 1000 Hz 1000 Hz - 4000 Hz	60	-	-	dB
		40	-	-	dB
DC Resistance @ 20°C, ±10%	Primary Winding Secondary Winding	-	108	-	Ohms
		-	120	-	Ohms
DC Current in Primary	-	-	0	-	mADC
Turns Ratio	Primary to Secondary; ±2%	-	1:1	-	Turns
Operating Temperature	-	-40	-	105	°C
Storage Temperature	-	-40	-	125	°C
Soldering Temperature	10 Sec. Max.	-	-	260	°C

600 OHM MATCH (Fig. 3)

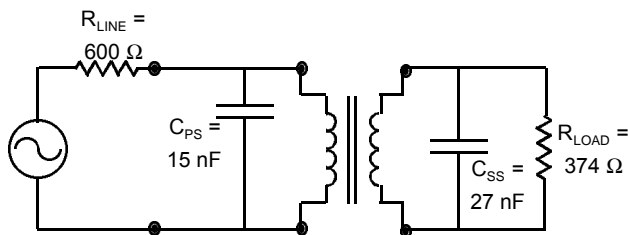

SCHEMATIC EQUIVALENT (Fig. 4)

(Typical Transformer Model @ 1 V, 1 kHz)

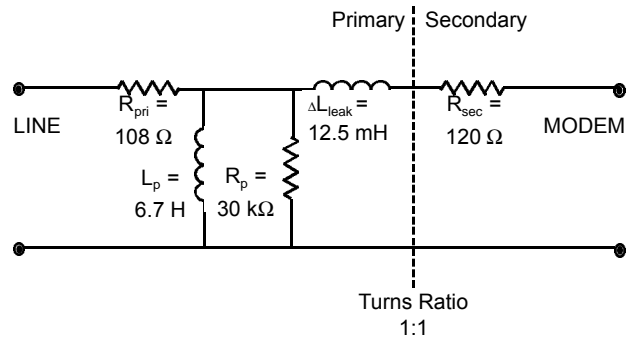

REMtech Corporation makes no assertion or warranty that the circuitry and the uses thereof disclosed herein are non-infringing on any valid US or foreign patents. REMtech assumes no liability as a result of the use of said specifications and reserves the right to make changes to specifications without notice. REMtech does not authorize or warrant any REMtech device for use in life support devices and/or systems. Contact your nearest REMtech Sales Office for the latest specifications.

Literature Number: DSB.MIT-4262
© Copyright 2000, REMtech Corporation
All rights reserved. Printed in U.S.A.
9/00

STANDARD PACKAGING (Fig. 9)

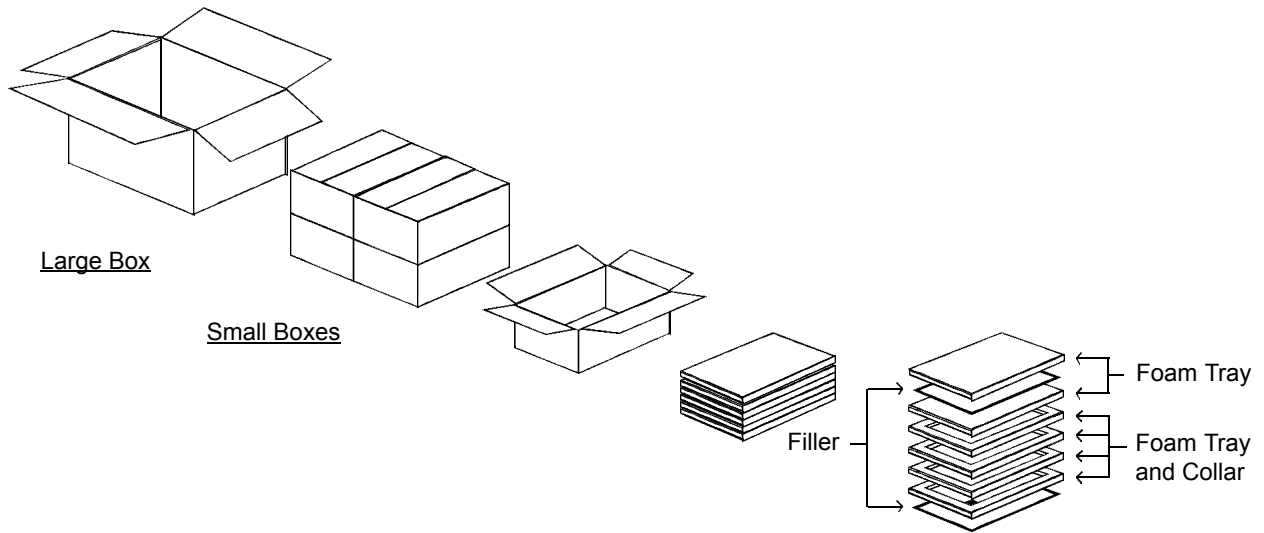

Packaging

Material	Contents	#Transformers
Large Box	4 Small Boxes	1280
Small Box	4 Trays	320
Tray	80 Transformers	80
---	Transformer	1

PAN-EUROPEAN CTR21 MATCH (Fig. 10)

(Application circuits available on request for specific national match requirements.)

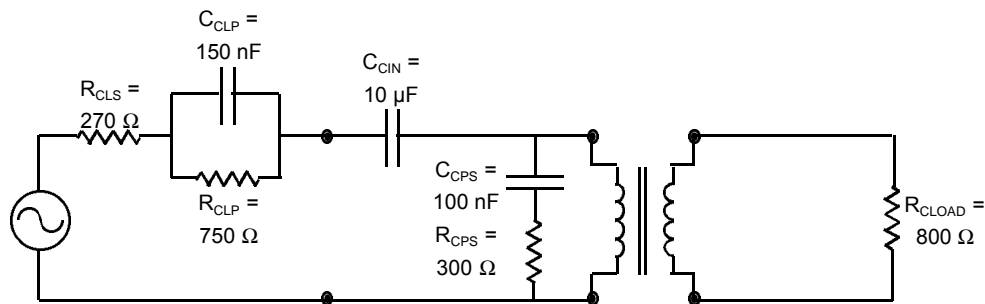

Literature Number: DSC.MIT-4262
 © Copyright 2000, REMtech Corporation
 All rights reserved. Printed in U.S.A.
 9/00

PERFORMANCE DATA

TOTAL HARMONIC DISTORTION (Fig. 5)

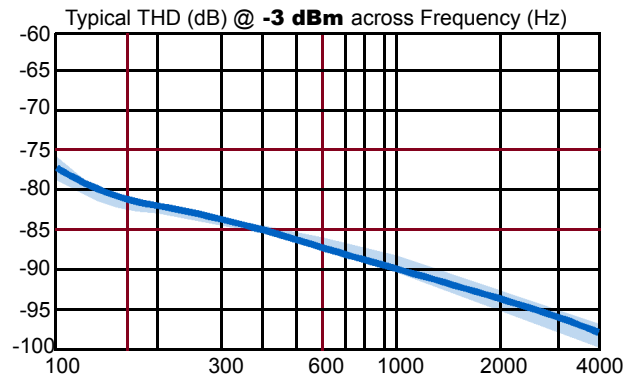
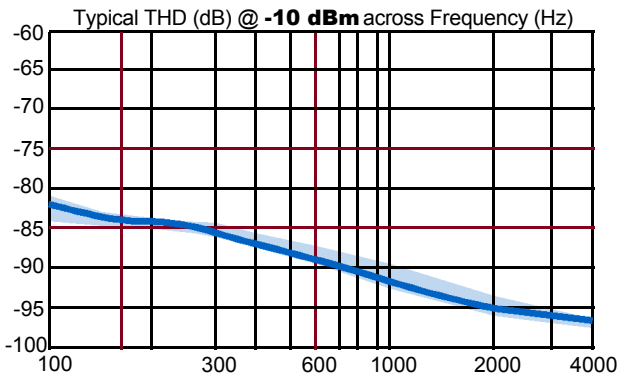

INSERTION LOSS (Fig. 6)

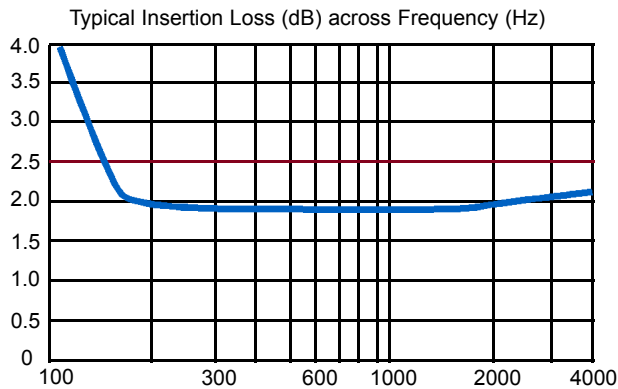

FREQUENCY RESPONSE (Fig. 7)

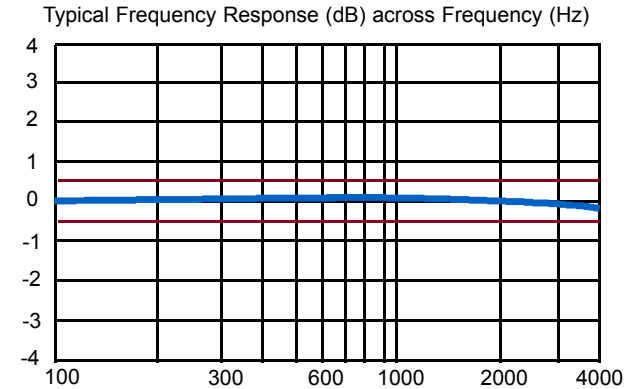

RETURN LOSS (Fig. 8)

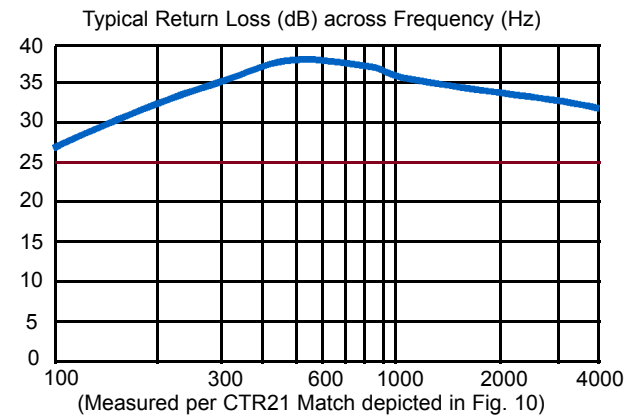
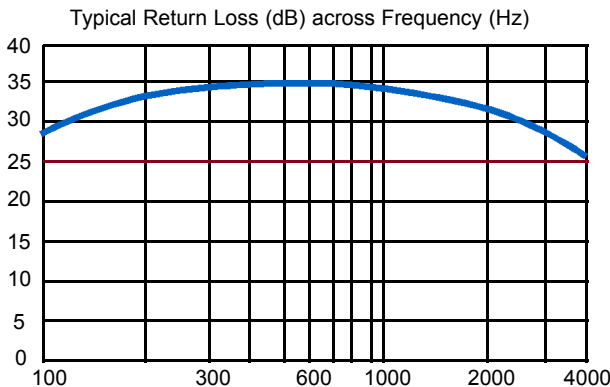

REMtech Corporation makes no assertion or warranty that the circuitry and the uses thereof disclosed herein are non-infringing on any valid US or foreign patents. REMtech assumes no liability as a result of the use of said specifications and reserves the right to make changes to specifications without notice. REMtech does not authorize or warrant any REMtech device for use in life support devices and/or systems. Contact your nearest REMtech Sales Office for the latest specifications.

Literature Number: DSD.MIT-4262
 © Copyright 2000, REMtech Corporation
 All rights reserved. Printed in U.S.A.
 9/00

ADDITIONAL DATA
RETURN LOSS (Fig. 8)

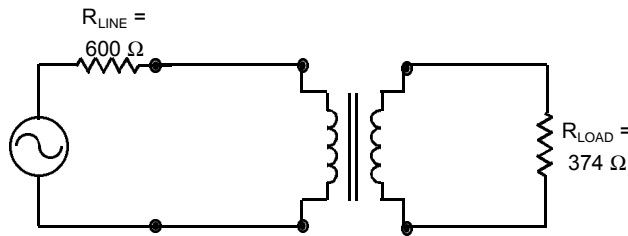
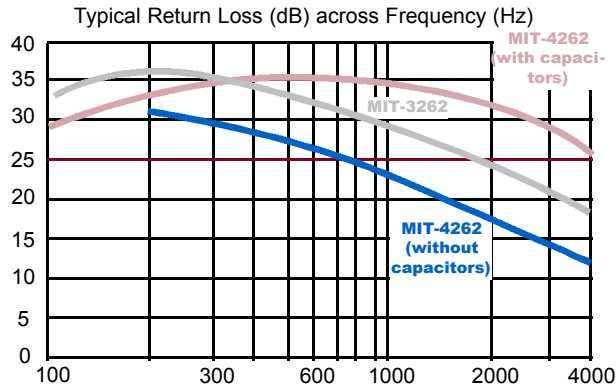

Customers may expect to use MIT-4262 as a “drop-in” upgrade to MIT-3262 in order to meet upcoming IEC60950 Supplementary worldwide safety standards. In Europe this standard is known as EN60950 Supplementary. In the US, this standard is known as UL1950, and it applies to all new system models introduced as of April 1, 2000. (Previous models continue to 2004.)

MIT-3262 boards typically will not include the extra capacitors recommended for best Return Loss results with MIT-4262, as depicted by the 600 Ohm Match (Fig. 3) circuit model.

Return Loss results depicted (to the left in blue) can be achieved according to the 600 Ohm Match circuit model shown. (This circuit model is identical to that indicated with the MIT-3262 specification.)

MIT-4262 distortion ratings remain excellent for 56K modems. However, Total Harmonic Distortion ratings for MIT-3262 are 4 to 8 dB better than MIT-4262. Other electrical specifications are nearly identical when comparing MIT-3262 to MIT-4262.