LOW NOISE 150mA LDO REGULATOR

NO.EA-211-090402

OUTLINE

The RP113Q Series are CMOS-based voltage regulator ICs with high output voltage accuracy, extremely low supply current, low ON-resistance, and high ripple rejection. Each of these ICs consists of a voltage reference unit, an error amplifier, resistor-net for voltage setting, a current limit circuit, and a chip enable circuit.

These ICs perform with low dropout voltage and a chip enable function. The line transient response and load transient response of the RP113Q Series are excellent, thus these ICs are very suitable for the power supply for hand-held communication equipment.

The output voltage of these ICs is fixed with high accuracy.

The electrical specifications of the RP113Q Series are completely same as the RP103x Series. Only the difference is the package for the RP113Qxx2. The package of RP113Q Series is small 5-pin SC-88A.

The pin layout of the RP113Qxx2 is different from the RP103Qxx2. Depending on the preference of the package or pinout, various options are available among RP113Q and RP103x Series.

FEATURES

- Supply Current Typ. 36 μ A
- Standby Mode Typ. 0.1 μ A
- Dropout Voltage..... Typ. 0.21V ($I_{OUT}=150\text{mA}$, $V_{OUT}=2.8\text{V}$)
- Ripple Rejection Typ. 75dB ($f=1\text{kHz}$)
- Temperature-Drift Coefficient of Output Voltage Typ. $\pm 30\text{ppm}/^\circ\text{C}$
- Line Regulation Typ. 0.02%/V
- Output Voltage Accuracy $\pm 1.0\%$
- Package SC-88A
- Input Voltage Range..... 1.7V to 5.25V
- Output Voltage..... 1.2V to 3.3V (For Standard Voltage, please refer to MARK INFORMATIONs to be described.)
- Built-in Fold Back Protection Circuit..... Typ. 40mA (Current at short mode)
- Ceramic capacitors are recommended to be used with this IC 0.47 μ F or more

APPLICATIONS

- Power source for portable communication equipment.
- Power source for electrical appliances such as cameras, VCRs and camcorders.
- Power source for battery-powered equipment.
- Power source for home appliances.

BLOCK DIAGRAMS

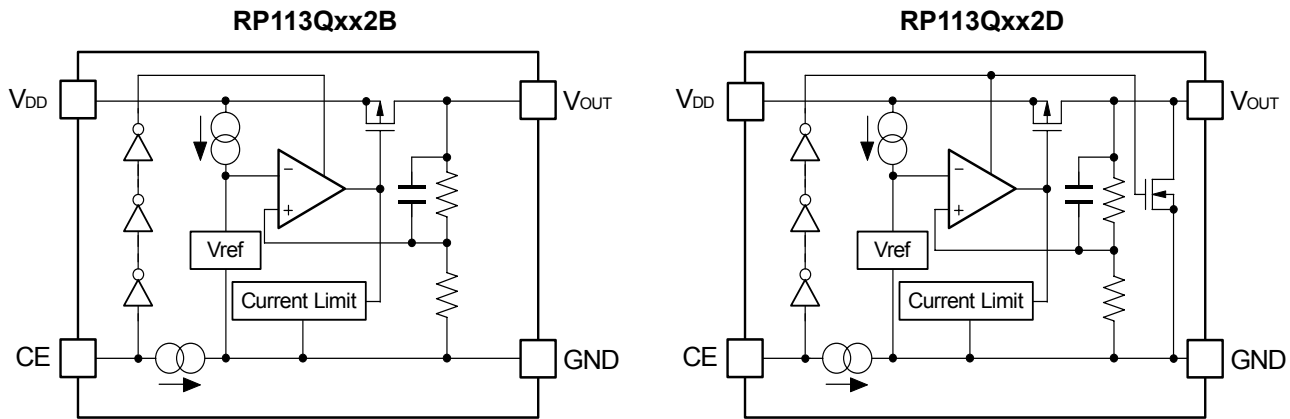

SELECTION GUIDE

The output voltage, auto discharge function*, and the taping type for the ICs can be selected at the user's request.

The selection can be made with designating the part number as shown below;

RP113Q $\overset{\uparrow}{a}$ $\overset{\uparrow}{b}$ $\overset{\uparrow}{c}$ $\overset{\uparrow}{d}$ $\overset{\uparrow}{e}$ xx2x-xx-x ←Part Number

Code	Contents
a	Designation of Package Type; Q: SC-88A
b	Setting Output Voltage (V_{OUT}): 1.2V to 3.3V (For Standard Voltage, please refer to MARK INFORMATIONs to be described.)
c	Designation of Mask Option B: active high, without auto discharge function* at OFF state. D: active high, with auto discharge function* at OFF state.
d	Designation of Taping Type: Ex. TR (Refer to Taping Specifications; TR type is the standard direction.)
e	Designation of composition of pin plating: -F : Lead free solder plating (SC-88A)

*) When the mode is into standby with CE signal, auto discharge transistor turns on, and it makes the turn-off speed faster than normal type.

PIN CONFIGURATIONS

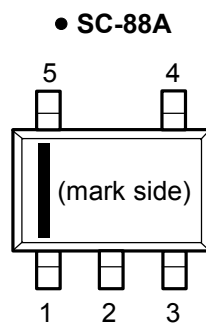

PIN DESCRIPTIONS

• SC-88A

Pin No.	Symbol	Description
1	V_{DD}	Input Pin
2	GND	Ground Pin
3	CE	Chip Enable Pin ("H" Active)
4	NC	No Connection
5	V_{OUT}	Output Pin

ABSOLUTE MAXIMUM RATINGS

Symbol	Item	Rating	Unit
V_{IN}	Input Voltage	6.0	V
V_{CE}	Input Voltage (CE Pin)	6.0	V
V_{OUT}	Output Voltage	-0.3 to $V_{IN}+0.3$	V
I_{OUT}	Output Current	180	mA
P_D	Power Dissipation* (SC-88A)	380	mW
T_{opt}	Operating Temperature Range	-40 to 85	°C
T_{stg}	Storage Temperature Range	-55 to 125	°C

*) For Power Dissipation, please refer to PACKAGE INFORMATION to be described.

ABSOLUTE MAXIMUM RATINGS

Electronic and mechanical stress momentarily exceeded absolute maximum ratings may cause the permanent damages and may degrade the life time and safety for both device and system using the device in the field.

The functional operation at or over these absolute maximum ratings is not assured.

RECOMMENDED OPERATING CONDITIONS (ELECTRICAL CHARACTERISTICS)

All of electronic equipment should be designed that the mounted semiconductor devices operate within the recommended operating conditions. The semiconductor devices cannot operate normally over the recommended operating conditions, even if when they are used over such conditions by momentary electronic noise or surge. And the semiconductor devices may receive serious damage when they continue to operate over the recommended operating conditions.

ELECTRICAL CHARACTERISTICS

• RP113Qxx2B/D

V_{IN} =Set $V_{OUT}+1V$ for V_{OUT} options greater than 1.5V. $V_{IN}=2.5V$ for $V_{OUT} \leq 1.5V$.

$I_{OUT}=1mA$, $C_{IN}=C_{OUT}=0.47\mu F$, unless otherwise noted.

 values indicate $-40^{\circ}C \leq T_{opt} \leq 85^{\circ}C$, unless otherwise noted.

$T_{opt}=25^{\circ}C$

Symbol	Item	Conditions	Min.	Typ.	Max.	Unit	
V_{OUT}	Output Voltage	$T_{opt}=25^{\circ}C$	$V_{OUT} > 2.0V$	$\times 0.99$		$\times 1.01$	V
			$V_{OUT} \leq 2.0V$	-20		+20	mV
		$-40^{\circ}C \leq T_{opt} \leq 85^{\circ}C$	$V_{OUT} > 2.0V$	$\times 0.985$		$\times 1.015$	V
			$V_{OUT} \leq 2.0V$	-30		+30	mV
I_{OUT}	Output Current		150			mA	
$\Delta V_{OUT}/\Delta I_{OUT}$	Load Regulation	$1mA \leq I_{OUT} \leq 150mA$		10	30	mV	
V_{DIF}	Dropout Voltage	$I_{OUT}=150mA$	$1.2V \leq V_{OUT} < 1.5V$		0.50	0.62	V
			$1.5V \leq V_{OUT} < 1.7V$		0.38	0.47	
			$1.7V \leq V_{OUT} < 2.0V$		0.34	0.42	
			$2.0V \leq V_{OUT} < 2.5V$		0.28	0.36	
			$2.5V \leq V_{OUT} < 2.8V$		0.22	0.30	
			$2.8V \leq V_{OUT} \leq 3.3V$		0.21	0.27	
I_{SS}	Supply Current	$I_{OUT}=0mA$		36	50	μA	
$I_{standby}$	Standby Current	$V_{CE}=0V$		0.1	1.0	μA	
$\Delta V_{OUT}/\Delta V_{IN}$	Line Regulation	Set $V_{OUT}+0.5V \leq V_{IN} \leq 5.0V$		0.02	0.10	%/V	
RR	Ripple Rejection	$f=1kHz$, Ripple 0.2Vp-p $V_{IN}=\text{Set } V_{OUT}+1V$, $I_{OUT}=30mA$ (In case that $V_{OUT} \leq 2.0V$, $V_{IN}=3.0V$)		75		dB	
V_{IN}	Input Voltage*		1.7		5.25	V	
$\Delta V_{OUT}/\Delta T_{opt}$	Output Voltage Temperature Coefficient	$-40^{\circ}C \leq T_{opt} \leq 85^{\circ}C$		± 30		ppm/ $^{\circ}C$	
I_{lim}	Short Current Limit	$V_{OUT}=0V$		40		mA	
I_{PD}	CE Pull-down Current			0.3		μA	
V_{CEH}	CE Input Voltage "H"		1.1			V	
V_{CEL}	CE Input Voltage "L"				0.3	V	
en	Output Noise	BW=10Hz to 100kHz $I_{OUT}=30mA$		60		μV_{rms}	
R_{LOW}	Low Output Nch Tr. ON Resistance (of D version)	$V_{IN}=4.0V$ $V_{CE}=0V$		30		Ω	

*) The maximum Input Voltage of the ELECTRICAL CHARACTERISTICS is 5.25V. In case of exceeding this specification, the IC must be operated on condition that the Input Voltage is up to 5.5V and the total operating time is within 500hrs.

All of unit are tested and specified under load conditions such that $T_j \approx T_{opt}=25^{\circ}C$ except for Output Noise, Ripple Rejection and Output Voltage Temperature Coefficient.

TYPICAL APPLICATION

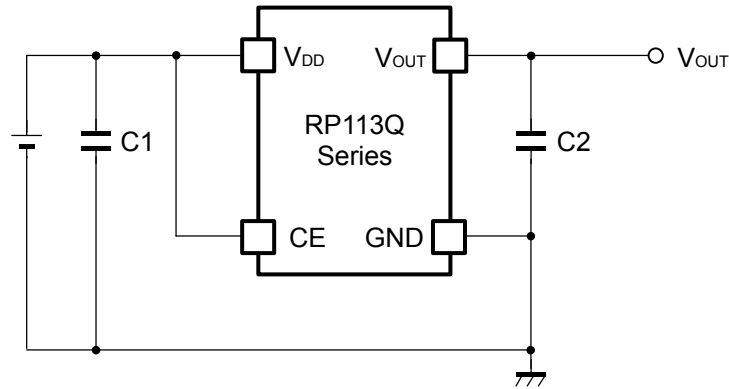

(External Components)

C2 0.47 μ F MURATA: GRM155B30J474KE18B

TECHNICAL NOTES

When using these ICs, consider the following points:

Phase Compensation

In these ICs, phase compensation is made for securing stable operation even if the load current is varied. For this purpose, use a capacitor C2 with good frequency characteristics and ESR (Equivalent Series Resistance). (Note: If additional ceramic capacitors are connected with parallel to the output pin with an output capacitor for phase compensation, the operation might be unstable. Because of this, test these ICs with as same external components as ones to be used on the PCB.)

PCB Layout

Make V_{DD} and GND lines sufficient. If their impedance is high, noise pickup or unstable operation may result. Connect a capacitor C1 with a capacitance value as much as 0.47 μ F or more between V_{DD} and GND pin, and as close as possible to the pins.

Set external components, especially the output capacitor C2, as close as possible to the ICs, and make wiring as short as possible.

TEST CIRCUITS

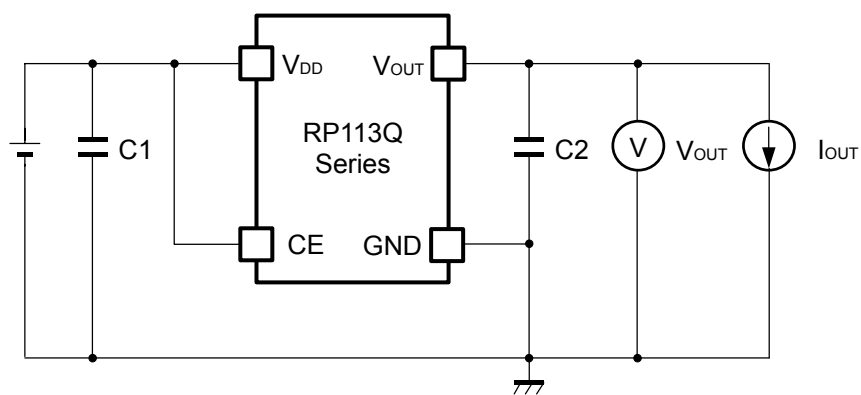

C1=Ceramic 0.47 μ F
C2=Ceramic 0.47 μ F

Basic Test Circuit

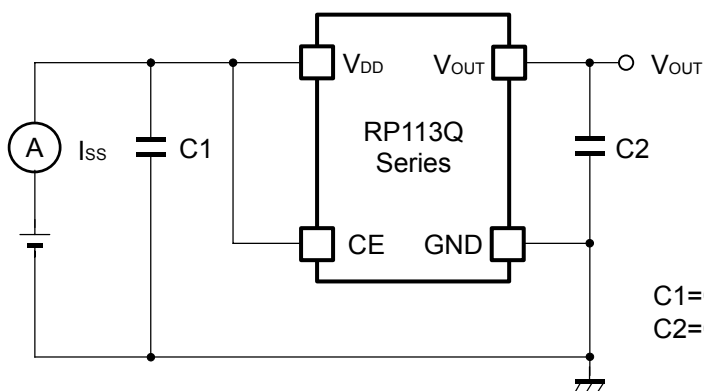

C1=Ceramic 0.47 μ F
C2=Ceramic 0.47 μ F

Test Circuit for Supply Current

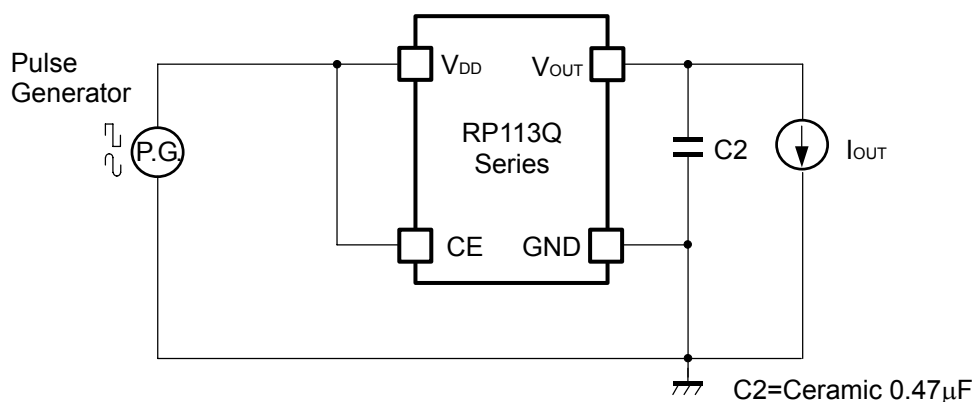

C2=Ceramic 0.47 μ F

Test Circuit for Ripple Rejection

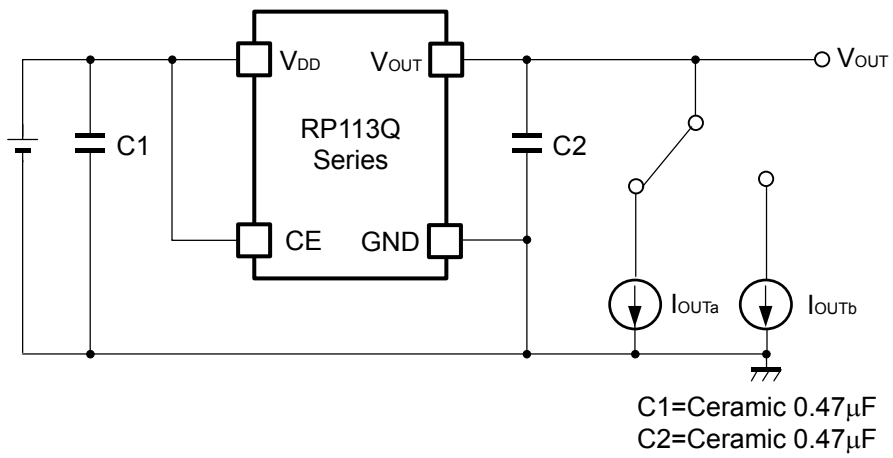

Test Circuit for Load Transient Response

TYPICAL CHARACTERISTICS

1) Output Voltage vs. Output Current ($C_1=0.47\mu\text{F}$, $C_2=0.47\mu\text{F}$, $T_{opt}=25^\circ\text{C}$)

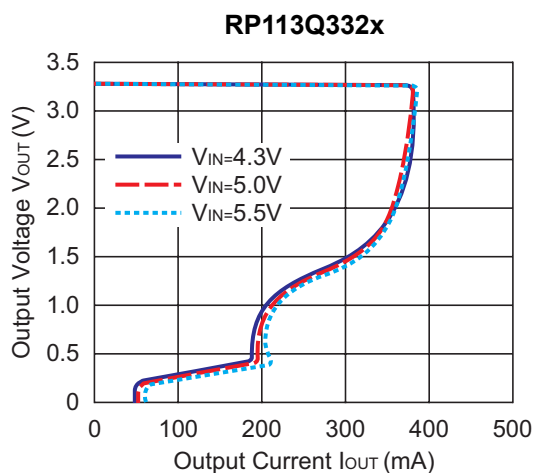
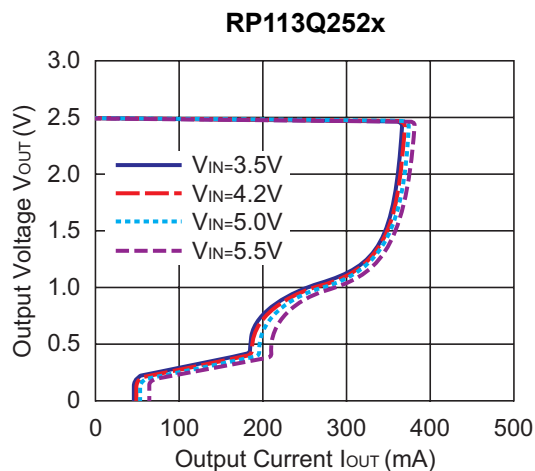
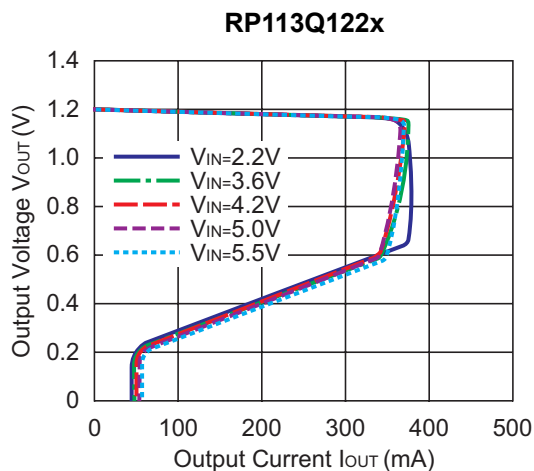

2) Output Voltage vs. Input Voltage ($C_1=0.47\mu\text{F}$, $C_2=0.47\mu\text{F}$, $T_{opt}=25^\circ\text{C}$)

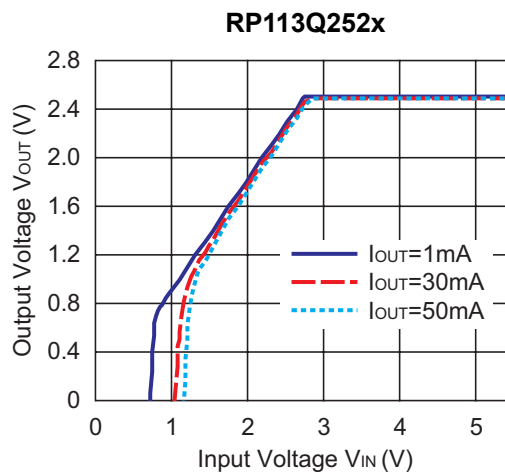
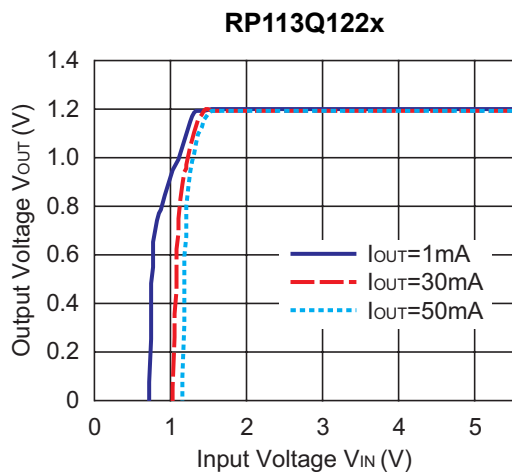

RP113Q332x

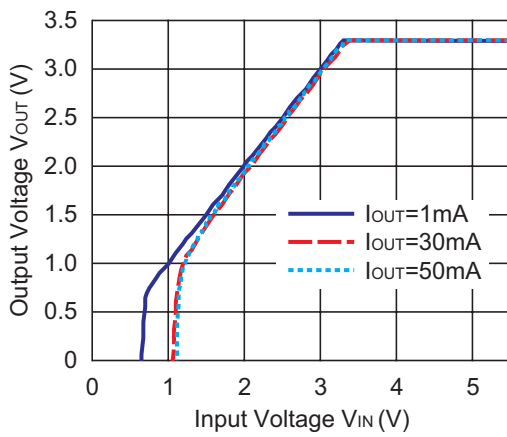

3) Supply Current vs. Input Voltage (C1=0.47μF, C2=0.47μF, Topt=25°C)

RP113Q122x

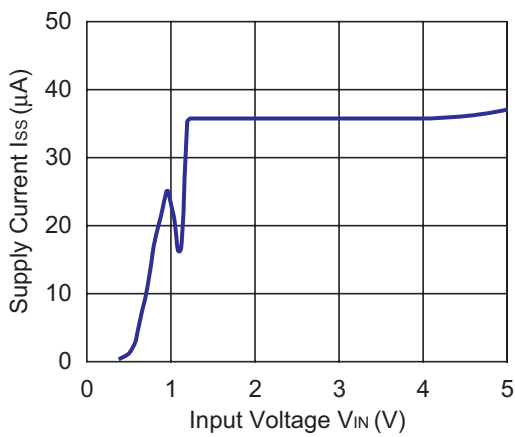

RP113Q252x

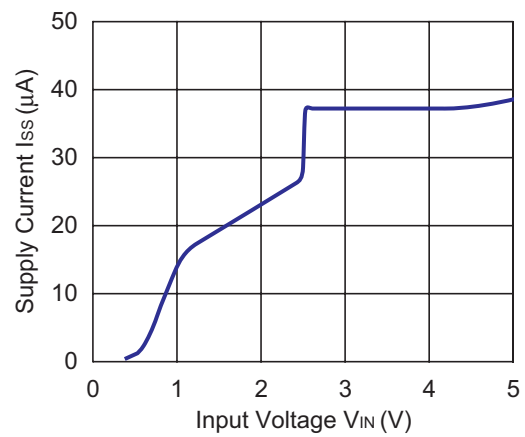

RP113Q332x

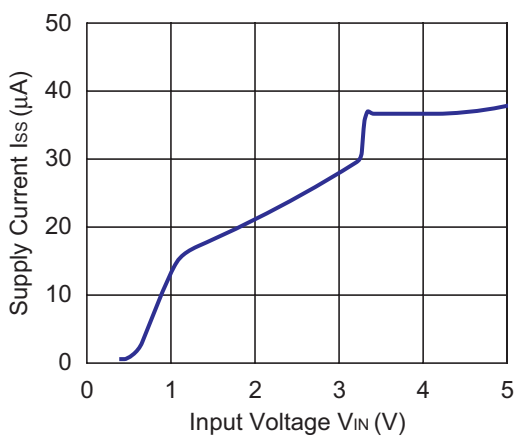

4) Output Voltage vs. Temperature (C1=0.47μF, C2=0.47μF, I_{OUT}=1mA)

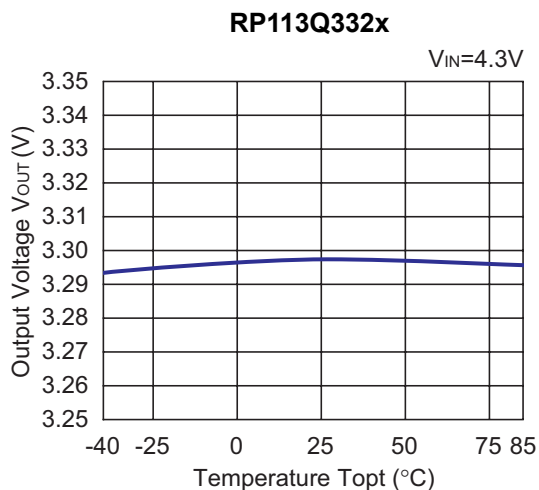
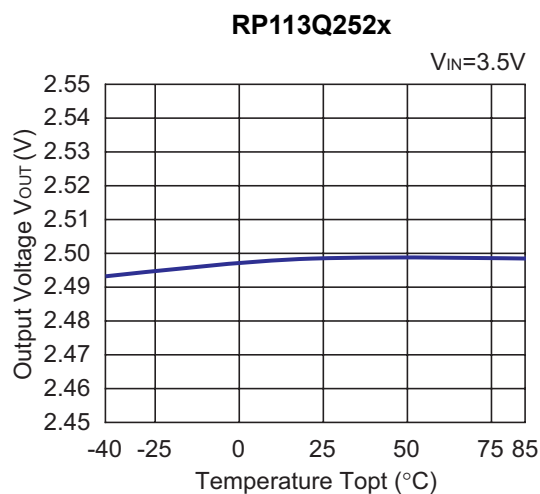
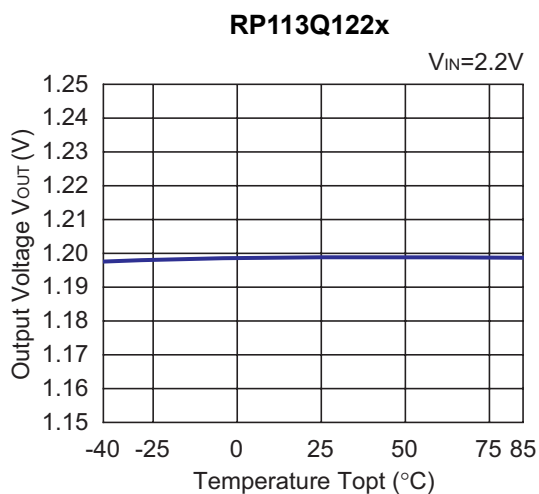

5) Supply Current vs. Temperature (C1=0.47μF, C2=0.47μF, I_{OUT}=0mA)

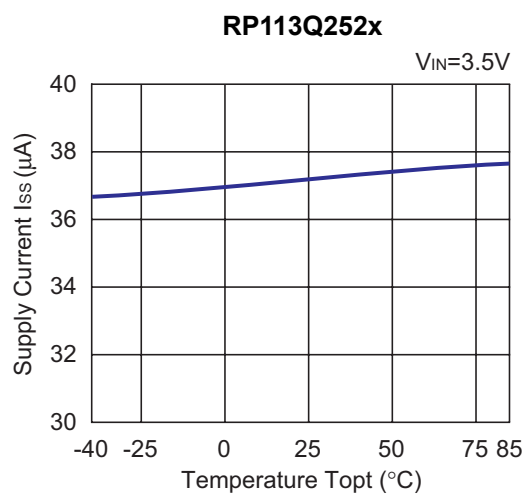
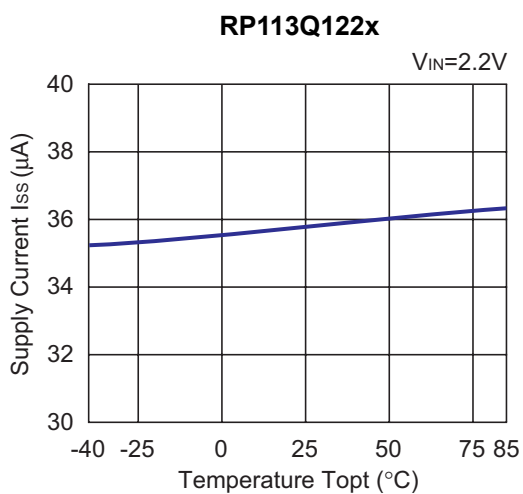

RP113Q332x

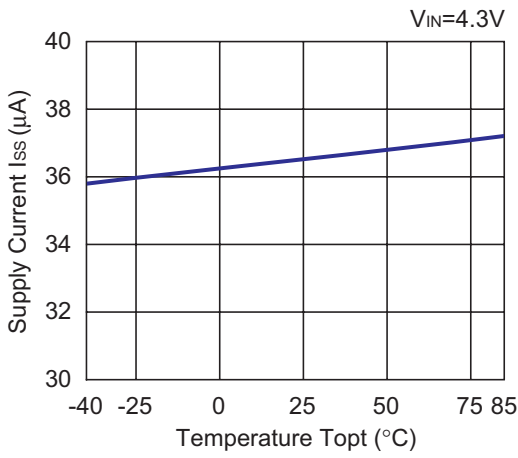

6) Dropout Voltage vs. Output Current ($C1=0.47\mu F$, $C2=0.47\mu F$)

RP113Q122x

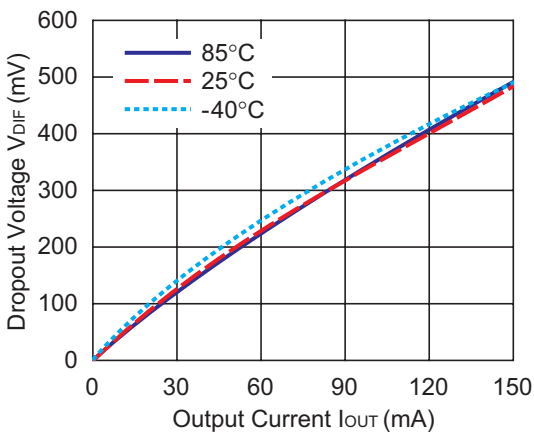

RP113Q252x

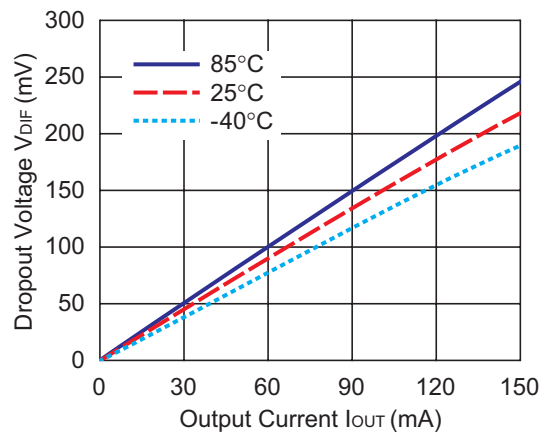

RP113Q332x

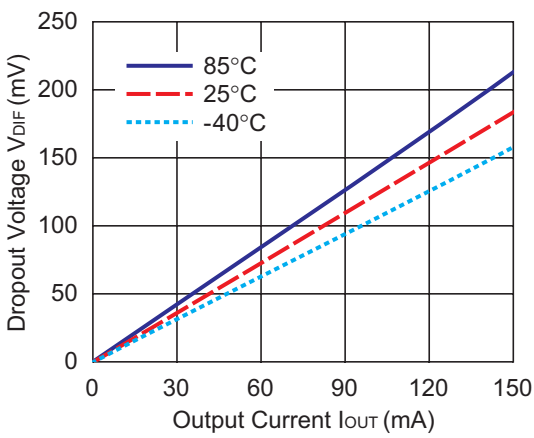

7) Dropout Voltage vs. Set Output Voltage (C1=0.47μF, C2=0.47μF, T_{opt}=25°C)

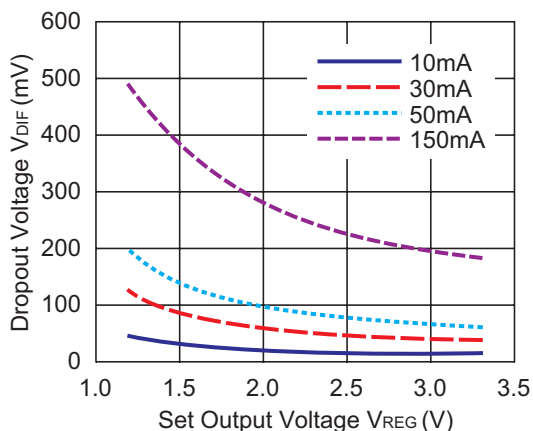

8) Ripple Rejection vs. Input Bias Voltage (C1=0.47μF, C2=0.47μF, Ripple=0.2Vp-p, T_{opt}=25°C)

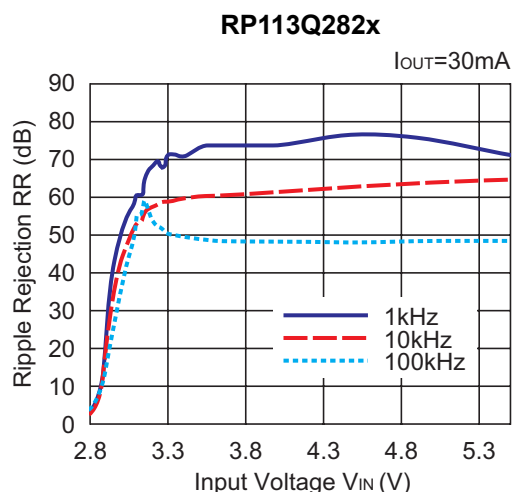
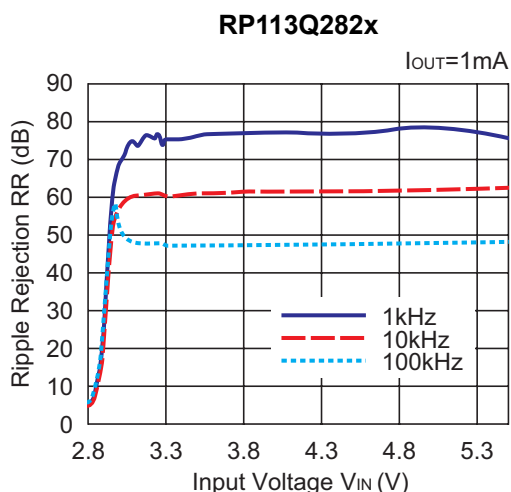

9) Ripple Rejection vs. Frequency (C1=none, C2=0.47μF, Ripple=0.2Vp-p)

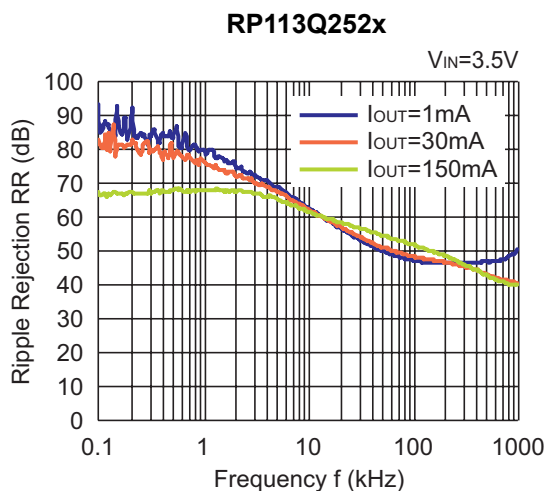
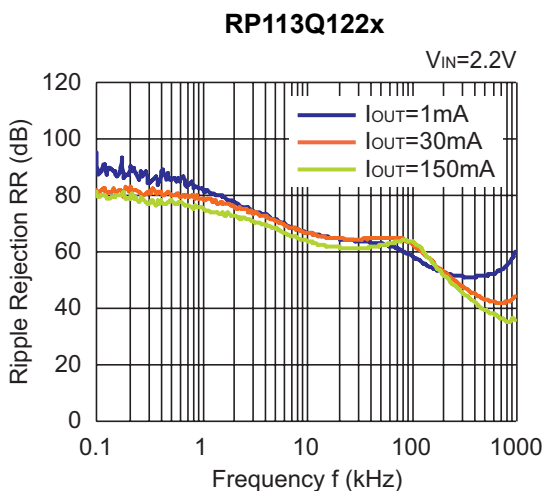

RP113Q332x

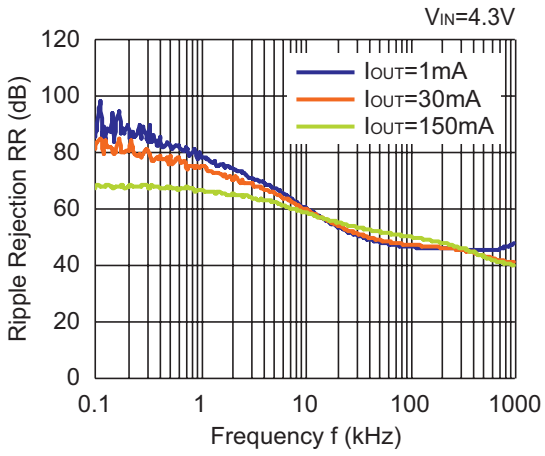

10) Input Transient Response ($C1=none$, $C2=0.47\mu F$, $I_{OUT}=30mA$, $t_r=t_f=5\mu s$, $T_{opt}=25^\circ C$)

RP113Q122x

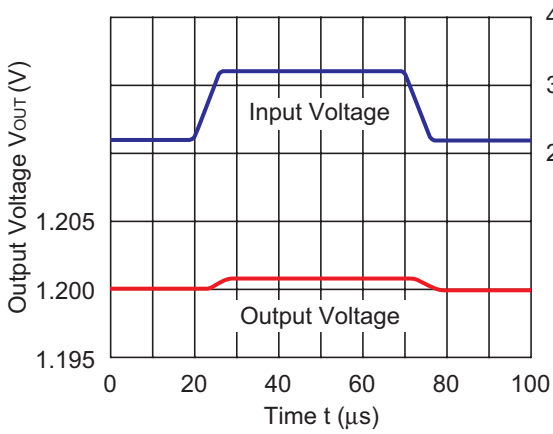

RP113Q252x

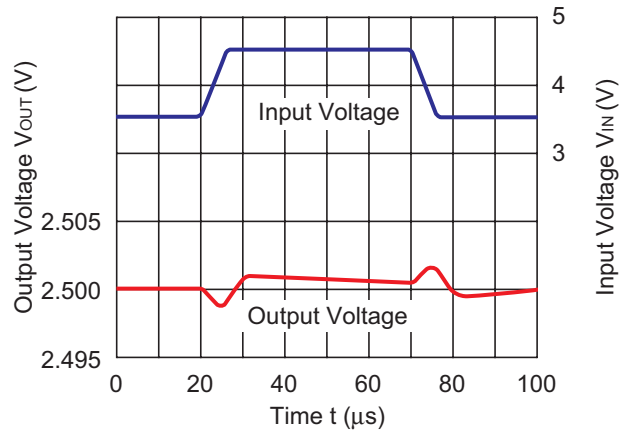

RP113Q332x

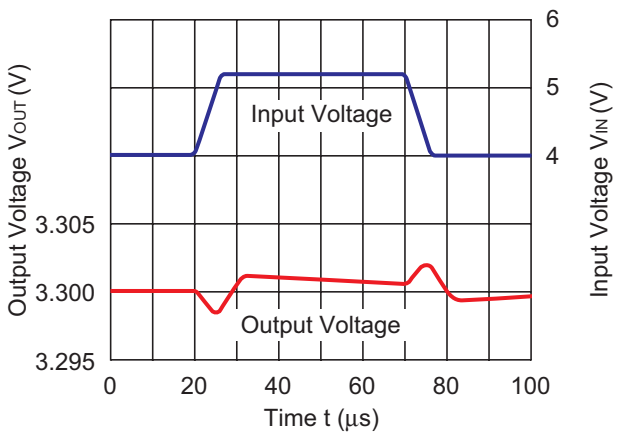

11) Load Transient Response ($C1=0.47\mu\text{F}$, $C2=0.47\mu\text{F}$, $T_{\text{opt}}=25^\circ\text{C}$)

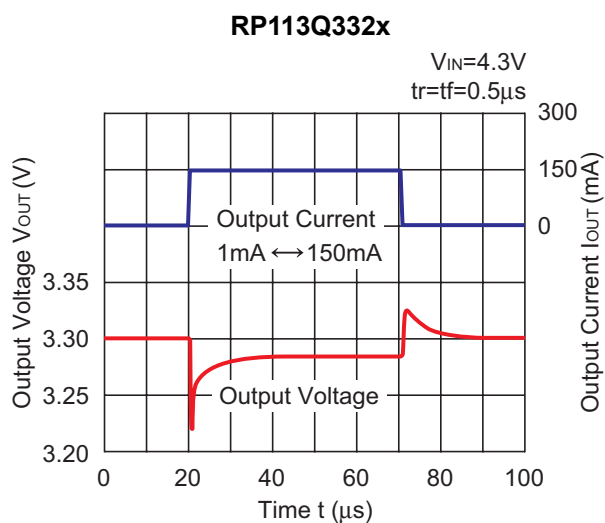
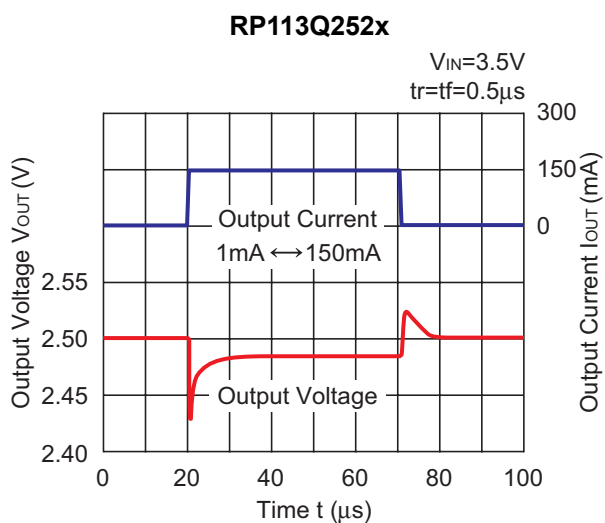
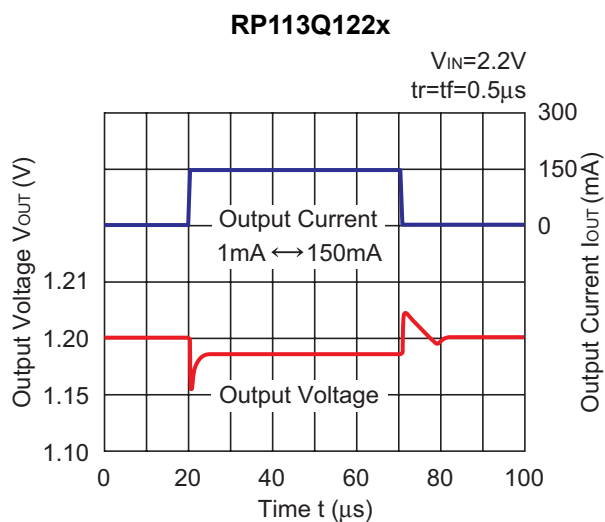
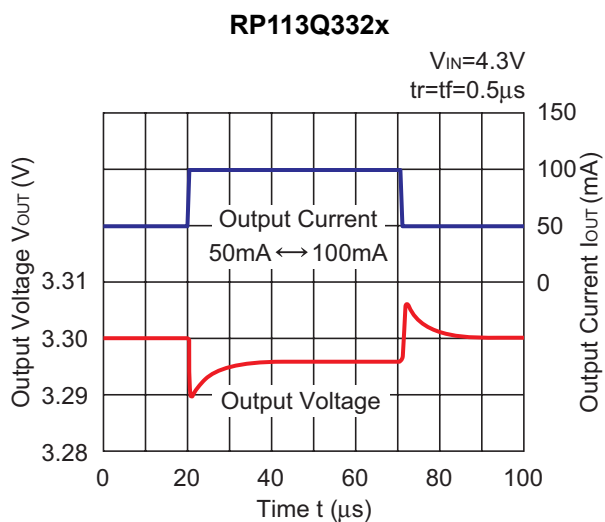
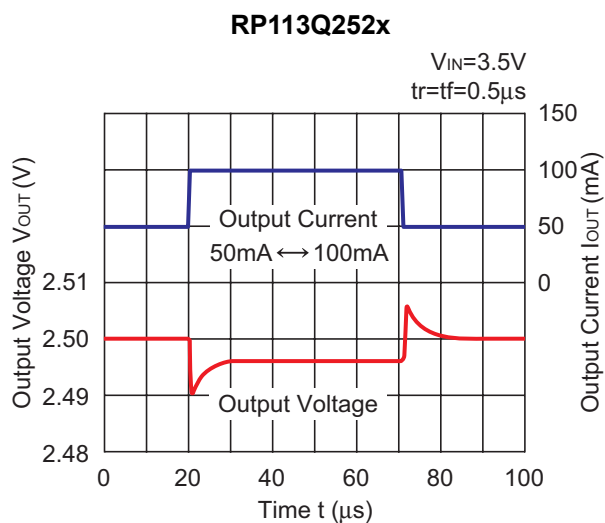
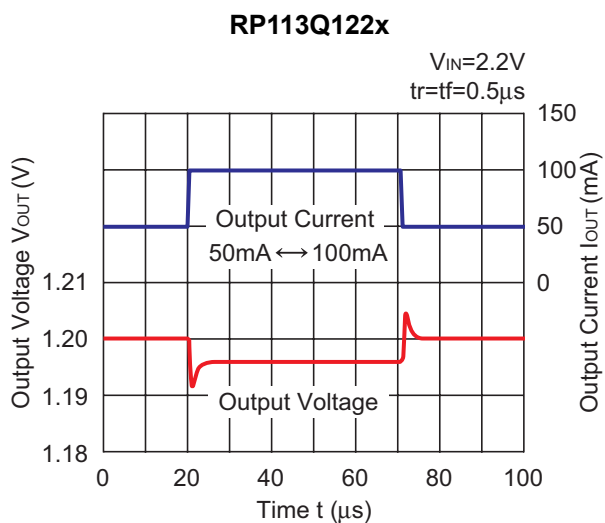

12) Turn On Speed with CE pin ($C1=0.47\mu\text{F}$, $C2=0.47\mu\text{F}$, $T_{opt}=25^\circ\text{C}$)

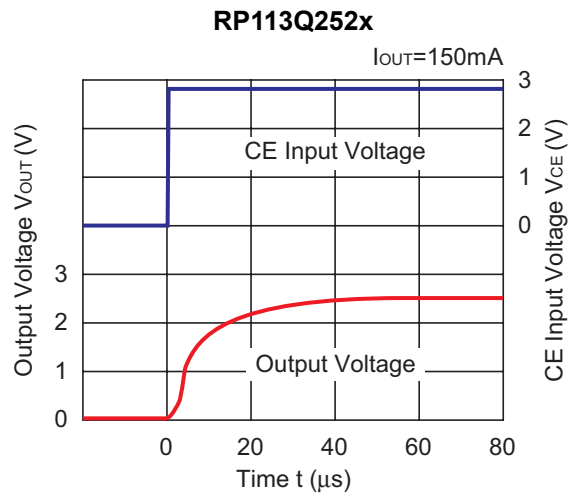
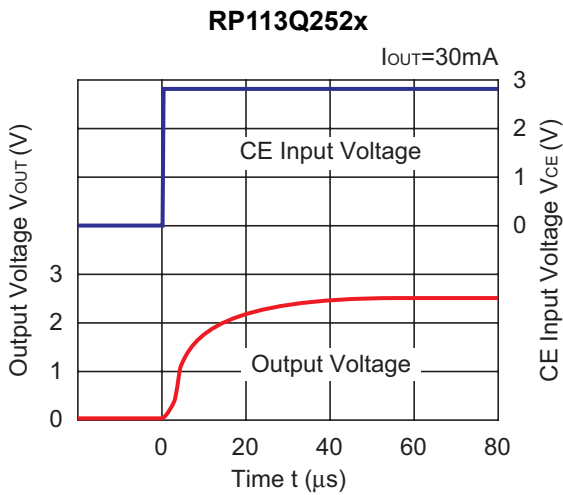
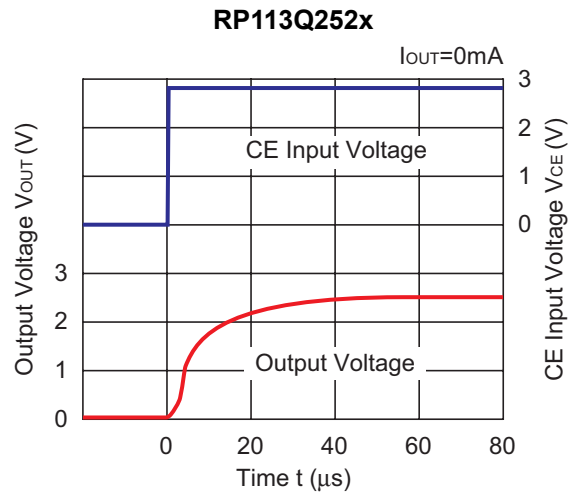
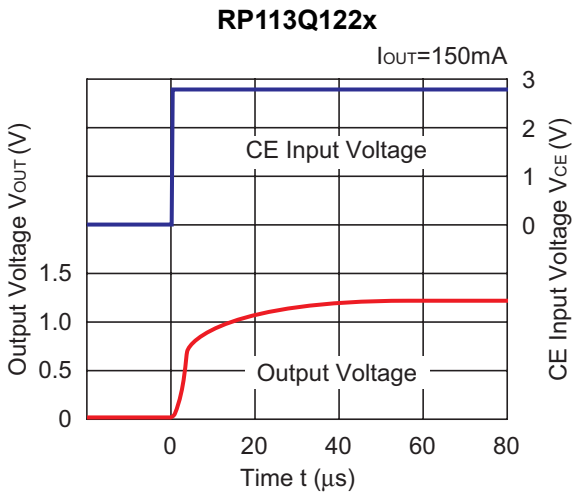
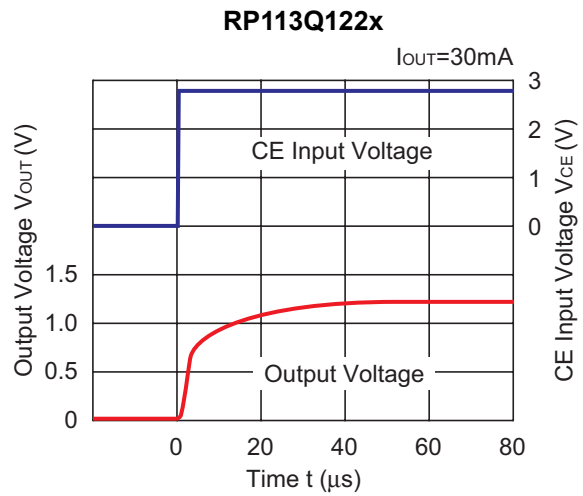
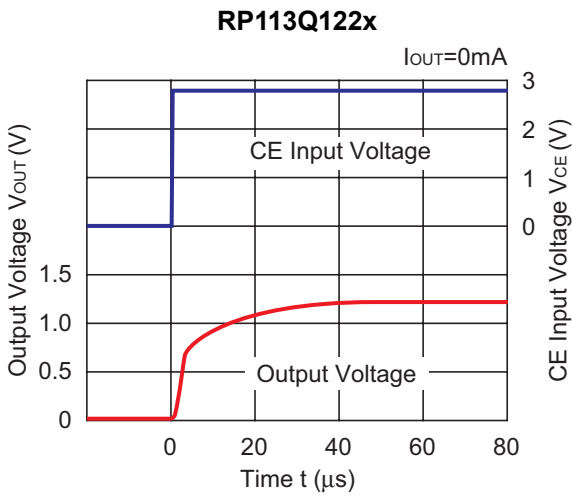

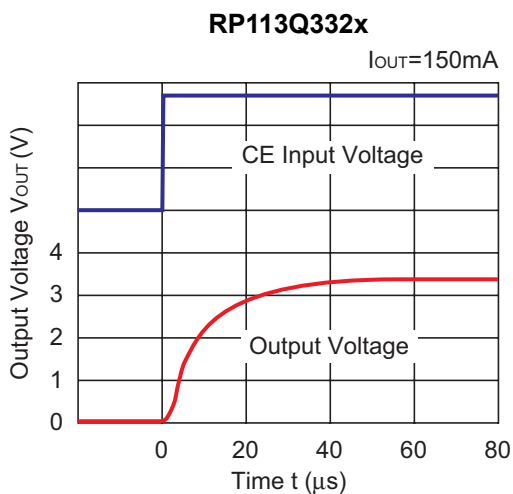
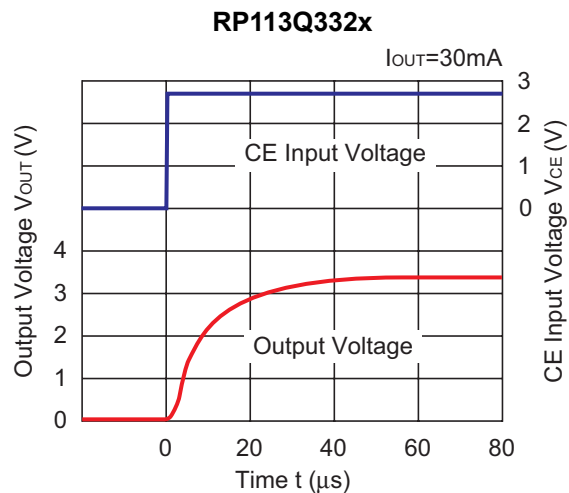
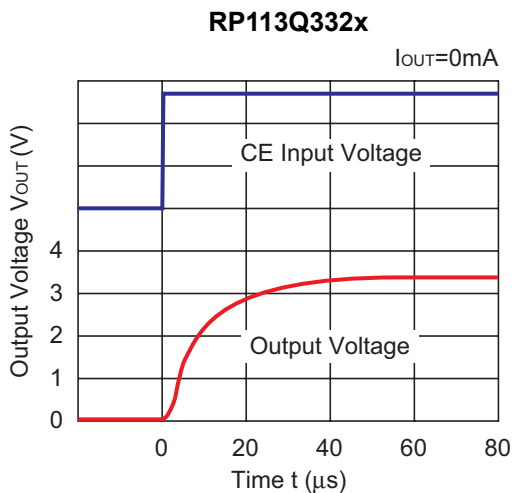

13) Turn Off Speed with CE pin (D Version) ($C1=0.47\mu F$, $C2=0.47\mu F$, $T_{opt}=25^{\circ}C$)

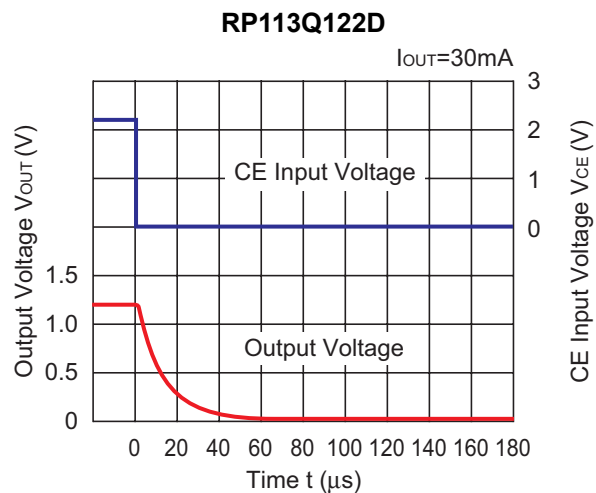
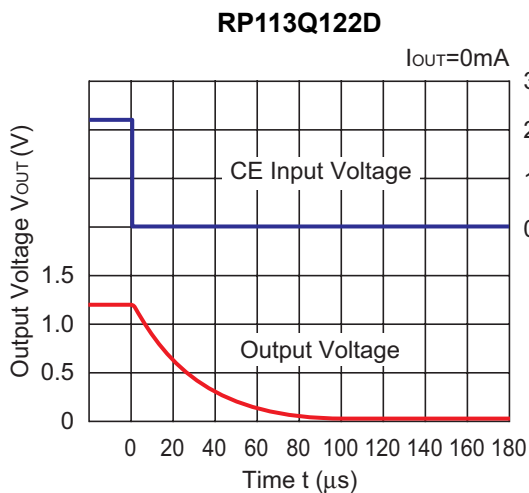

RP113Q122D

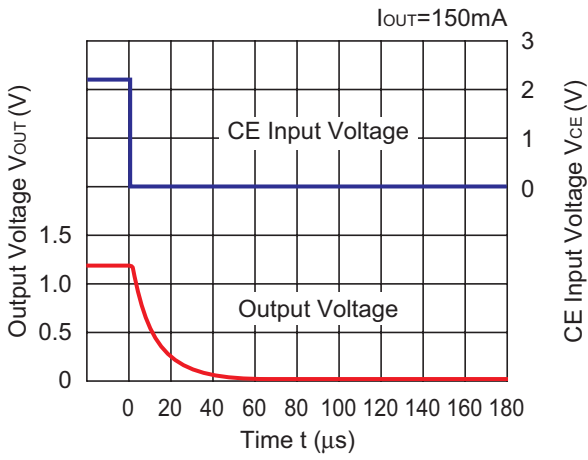

RP113Q252D

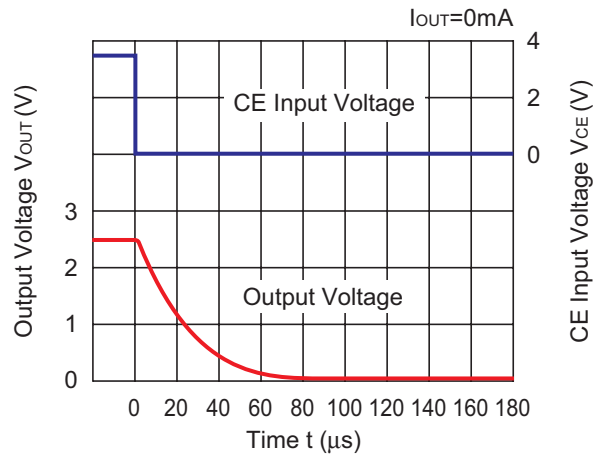

RP113Q252D

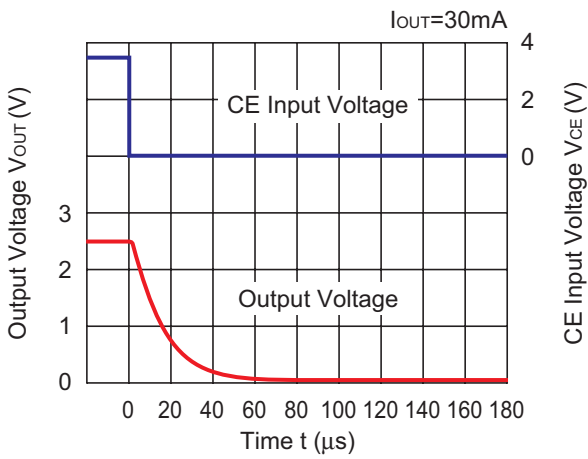

RP113Q252D

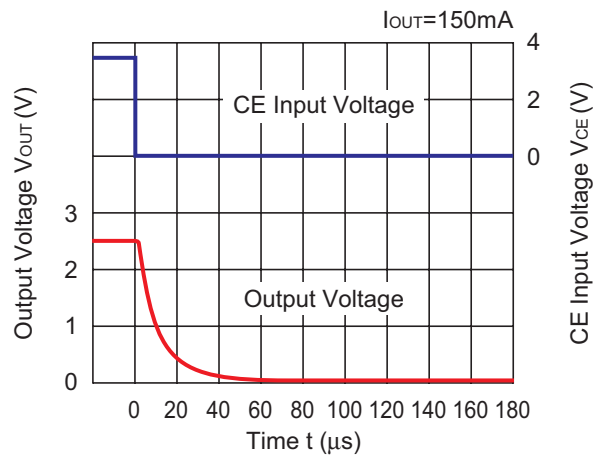

RP113Q332D

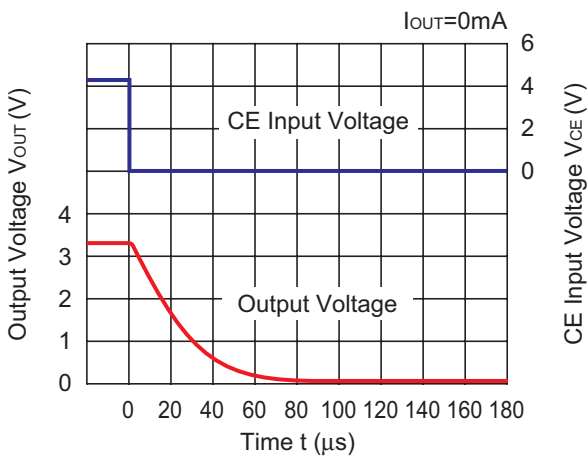

RP113Q332D

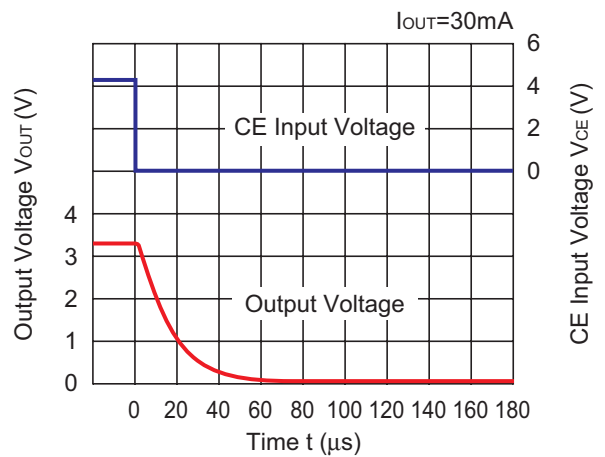

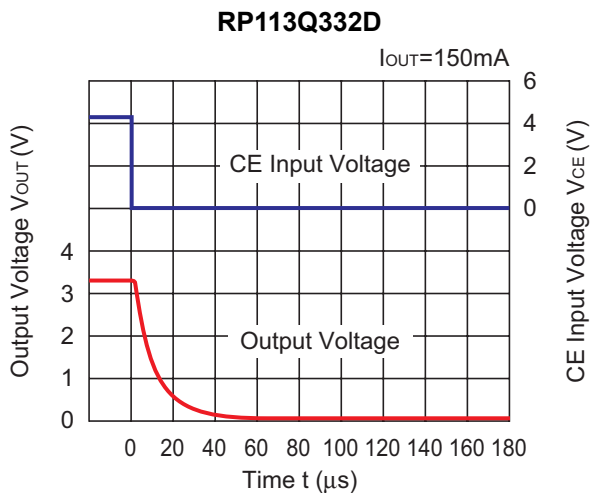

14) Dropout Voltage vs. Temperature ($C1=0.47\mu F$, $C2=0.47\mu F$)

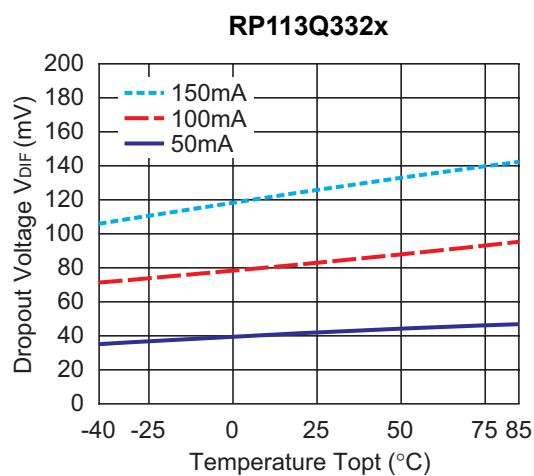
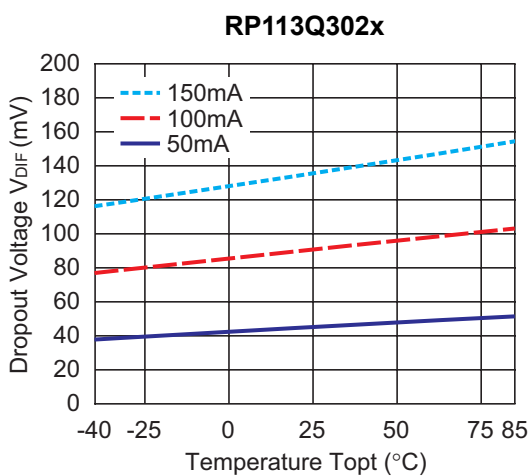
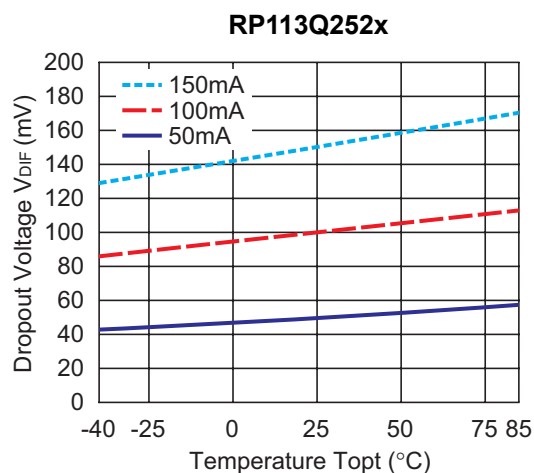
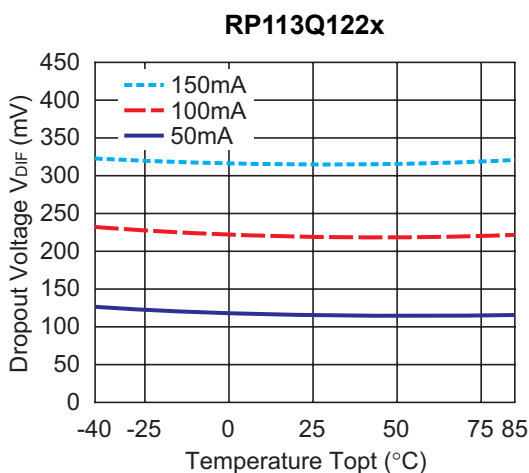

ESR vs. Output Current

When using these ICs, consider the following points:

The relations between I_{OUT} (Output Current) and ESR of an output capacitor are shown below.

The conditions when the white noise level is under $40\mu\text{V}$ (Avg.) are marked as the hatched area in the graph.

Measurement conditions

Frequency Band : 10Hz to 2MHz

Temperature : -40°C to 85°C

