

OUTLINE

The R1285L 2ch DC/DC converter is designed for OLED Display power source. It contains a step up DC/DC converter and an inverting DC/DC converter to generate two required voltages by OLED Display.

Step up DC/DC converter generates boosted output voltage to 4.6V ~ 5.0V. Inverting DC/DC converter generates negative voltage -2.0V ~ -6.0V independently. Each of the R1285 series consists of an oscillator, a PWM control circuit, a voltage reference, error amplifiers, over current protection circuits, short protection circuits, an under voltage lockout circuit (UVLO), a complete shutdown switch and an Nch driver for boost operation, a Pch driver for inverting, and so on. A high efficiency boost and inverting DC/DC converter can be composed with external inductors, diodes, capacitors and resistors. Start up sequence is internally made.

FEATURES

- Operating Voltage ••••• 2.3V ~ 4.8V
- Step Up DC/DC (CH1)
 - Internal Pch MOSFET for complete shutdown (Ron=300mΩTyp.)
 - Internal Nch MOSFET Driver (Ron=300mΩTyp.)
 - Output Voltage (V_{OUTP}) ••••• 4.6V ~ 5.0V (0.2VStep)
 - Auto Discharge function for positive output
 - Internal Soft start function (Typ. 4.5ms)
 - Over Current Protection
 - Maximum Duty Cycle: 85%(Typ.)
- Inverting DC/DC (CH2)
 - Internal Pch MOSFET Driver (Ron=600mΩ Typ.)
 - Output Voltage (V_{OUTN}) ••••• -2V ~ -6V (0.1VStep) [R1285LxxxA]
 - Adjustable Vout Up to -6V with external resistors [R1285L00xB]
 - Auto Discharge function for negative output
 - Internal Soft start function (Typ. 4.5ms)
 - Over Current Protection
 - Maximum Duty Cycle: 90%(Typ.)
- Control
 - Short Protection with timer latch function (Typ. 50ms)
 - Short condition for either or both two outputs makes all output drivers off and latches. If the maximum duty cycle continues for a certain time, these output drivers will be turned off. This function prevents irregular current from overheating the R1285 .
 - CE with start up sequence function (CH1→CH2)
 - UVLO function.
 - Operating Frequency ••••• 1400kHz
- Small package ••••• DFN12 (2.7mm x 3.0mm)

APPLICATION

- Fixed voltage power supply for portable equipment
- Fixed voltage power supply for OLED

BLOCK DIAGRAM

●R1285LxxxA

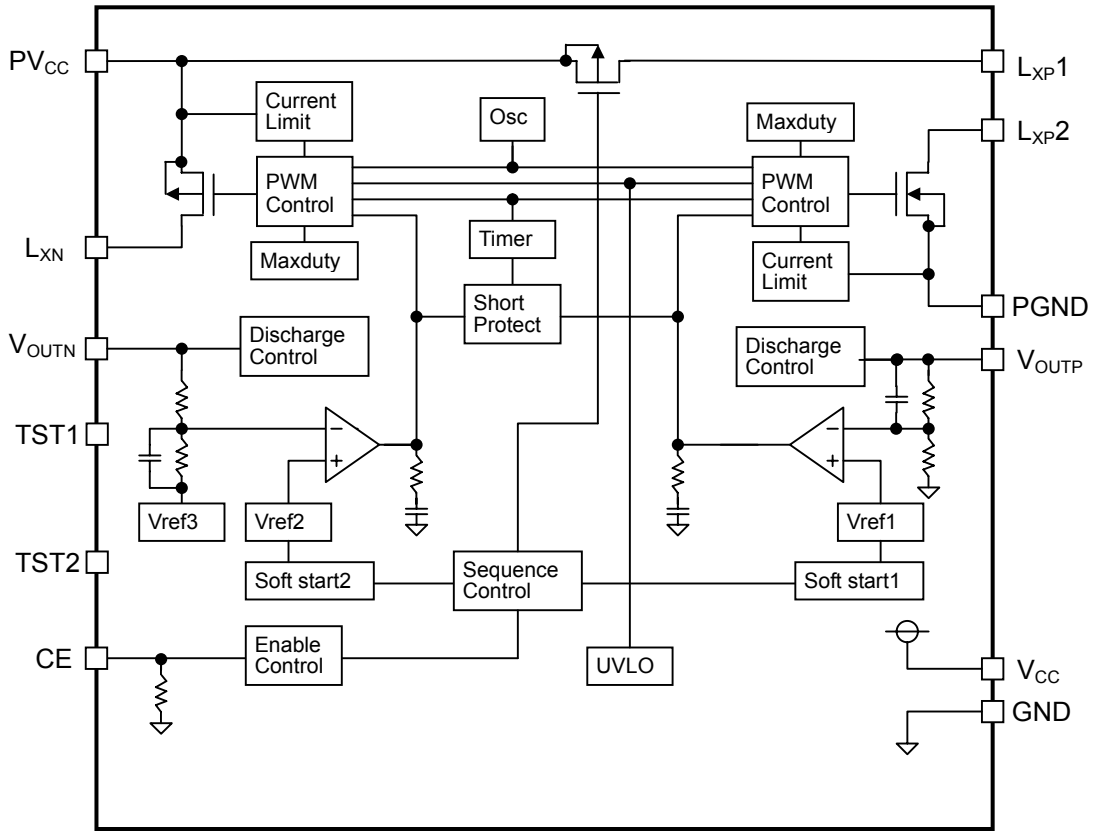

●R1285L00xB

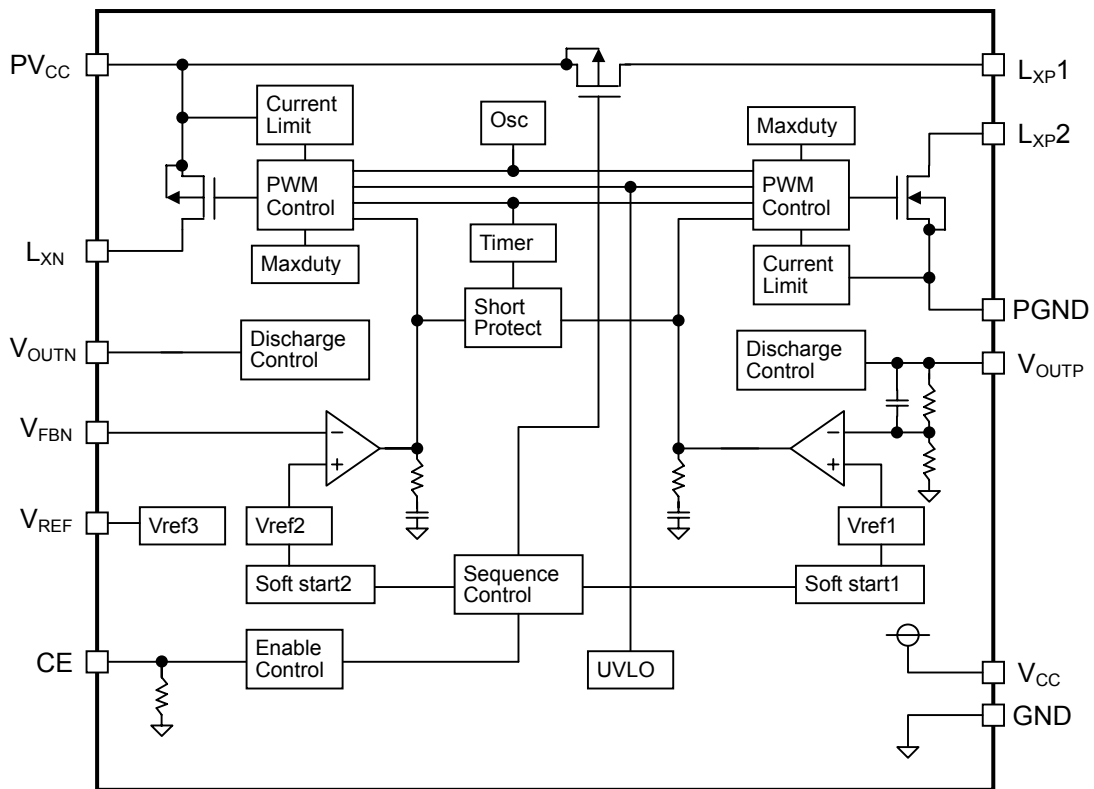

SELECTION GUIDE

The mask option for the ICs can be selected at the user's request. The selection can be made with designating the part number as shown below.

R 1 2 8 5 L XX X X ←Part Number
 ↓ ↓ ↓
 a b c

code	contents
a	Setting inverting output voltage (V_{OUTN}) Stepwise setting with a step of 0.1V in the range of -2.0V to -6.0V is possible for fixed output version (R1285LXXXXA) "00" is for Output Voltage Adjustable version (R1285L00XB)
b	Setting positive output voltage (V_{OUTP}) 1: 4.6V 2: 4.8V 3: 5.0V
c	Designation of method of setting V_{OUTN} A: Fixed output version B: Adjustable version

PIN CONFIGURATION

● DFN -2730-12

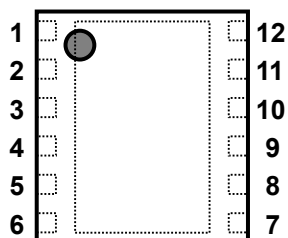

Top View

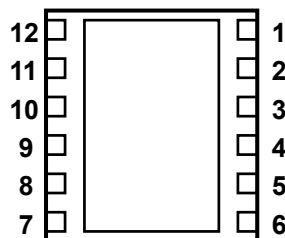

Bottom View

PIN DESCRIPTIONS

●R1285LxxxA

PIN No.	NAME	FUNCTION
1	PGND	Power GND pin
2	V _{OUTP}	Output Voltage feedback pin for Step up DC/DC
3	PV _{CC}	Power input pin
4	V _{CC}	Analog power source input pin
5	GND	Analog GND pin
6	CE	Chip enable pin
7	TST2	TEST pin
8	TST1	TEST pin
9	V _{OUTN}	Output Voltage feedback pin for Inverting DC/DC
10	L _{XN}	Switching pin for Inverting DC/DC
11	L _{XP1}	Shutdown switch output pin
12	L _{XP2}	Switching pin for Step up DC/DC

●R1285L00xB

PIN No.	NAME	FUNCTION
1	PGND	Power GND pin
2	V _{OUTP}	Output Voltage feedback pin for Step up DC/DC
3	PV _{CC}	Power input pin
4	V _{CC}	Analog power source input pin
5	GND	Analog GND pin
6	CE	Chip enable pin
7	V _{REF}	Reference voltage output pin for Inverting DC/DC
8	V _{FBN}	Feedback pin for Inverting DC/DC
9	V _{OUTN}	Output Voltage feedback pin for Inverting DC/DC
10	L _{XN}	Switching pin for Inverting DC/DC
11	L _{XP1}	Shutdown switch output pin
12	L _{XP2}	Switching pin for Step up DC/DC

ABSOLUTE MAXIMUM RATINGS

(GND / PGND=0V)

Item	Symbol	Rating	Unit
V _{CC} / PV _{CC} pin Voltage	V _{CC}	6.0	V
V _{OUTP} pin Voltage	V _{OUTP}	-0.3 ~ 6.0	V
CE pin Voltage	V _{CE}	-0.3 ~ 6.0	V
L _{XP1} pin Voltage	V _{LXP1}	-0.3 ~ V _{CC} +0.3	V
L _{XP2} pin Voltage	V _{LXP2}	-0.3 ~ 6.0	V
L _{XN} pin Voltage	V _{LXN}	V _{CC} -14 ~ V _{CC} +0.3	V
V _{OUTN} pin Voltage	V _{OUTN}	V _{CC} -14 ~ V _{CC} +0.3	V
TST1/TST2 pin Voltage [R1285LxxxA]	V _{TST}	-0.3 ~ V _{CC} +0.3	V
V _{FBN} pin Voltage [R1285L00xB]	V _{FBN}	-0.7 ^{*2} ~ V _{CC} +0.3	V
V _{REF} pin Voltage [R1285L00xB]	V _{REF}	-0.7 ^{*2} ~ V _{CC} +0.3	V
Power Dissipation ^{*1}	PD	1000	mW
Operating Temperature Range	T _a	-40 ~ +85	°C
Storage Temperature Range	T _{stg}	-55 ~ +125	°C

*1) For Power Dissipation, please refer to PACKAGE INFORMATION to be described.

*2) In case the voltage range is from -0.7V to -0.3V, permissible current is 10mA or less.

ABSOLUTE MAXIMUM RATINGS

Absolute Maximum ratings are threshold limit values that must not be exceeded ever for an instant under any conditions. Moreover, such values for any two items must not be reached simultaneously. Operation above these absolute maximum ratings may cause degradation or permanent damage to the device. These are stress ratings only and do not necessarily imply functional operation these limits.

ELECTRICAL CHARACTERISTICS

(Ta=25°C)

Symbol	Item	Conditions	MIN.	TYP.	MAX.	Unit.
V _{CC}	Operating Input Voltage		2.3		4.8	V
I _{CC1}	V _{CC} Consumption Current (switching)	V _{CC} =4.8V		4.0		mA
I _{CC2}	V _{CC} Consumption Current (at no switching)	V _{CC} =4.8V		350		uA
I _{STB}	Standby Current	V _{CC} =4.8V		0.1	3	uA
V _{UVLO1}	UVLO Detect Voltage	Falling	1.95	2.05	2.15	V
V _{UVLO2}	UVLO Released Voltage	Rising		V _{UVLO1} +0.10	2.28	V
F _{OSC}	Oscillator Frequency	V _{CC} =3.7V	1200	1400	1600	kHz
T _{DLY}	Delay Time for Protection	V _{CC} =3.7V		50		ms
V _{CEL}	CE "L" Input Voltage	V _{CC} =2.3V			0.3	V
V _{CEH}	CE "H" Input Voltage	V _{CC} =4.8V	1.5			V
R _{CE}	CE pin Pulldown Resistance	V _{CC} =3.7V		600		kΩ
■ Boost DC/DC						
V _{OUTP}	V _{OUTP} Voltage Tolerance	V _{CC} =3.7V	x0.985		x1.015	V
ΔV _{OUTP} /ΔT	V _{OUTP} Voltage Temperature Coefficient	V _{CC} =3.7V, -40°C ≤ Ta ≤ 85°C		±150		ppm/°C
ΔV _{OUTP} /ΔV _{CC}	V _{OUTP} Voltage Line Regulation	2.9V ≤ V _{CC} ≤ 3.4		±4		mV
ΔV _{OUTP} /ΔI _{OUT}	V _{OUTP} Voltage Load Regulation	V _{CC} =3.7V, 10mA ≤ I _{OUT} ≤ 100mA		±10		mV
ΔV _{OUTP_TR}	V _{OUTP} Voltage Line Transient Response	V _{CC} =2.9V ↔ 3.4V, T _R =T _F =50us		±10		mV
Maxduty1	CH1 Max. Duty Cycle	V _{CC} =3.7V	78	85		%
T _{SS1}	CH1 Soft-Start Time	V _{CC} =3.7V		4.5		ms
R _{LXP1}	L _{XP1} ON Resistance	V _{CC} =3.7V		300		mΩ
I _{OFF LXP1}	L _{XP1} Leakage Current	V _{CC} =4.8V, V _{LXP1} =0V			5	uA
R _{LXP2}	L _{XP2} ON Resistance	V _{CC} =3.7V		300		mΩ
I _{OFF LXP2}	L _{XP2} Leakage Current	V _{CC} =4.8V, V _{LXP2} =5V			5	uA
I _{LIMLXP2}	L _{XP2} Current Limit	V _{CC} =3.7V	0.7	1.0		A
I _{VOUTP}	V _{OUTP} Discharge Current	V _{CC} =3.7V, V _{OUTP} =0.1V		10		mA

■ Inverting DC/DC [R1285LxxxA]						
V _{OUTN}	V _{OUTN} Voltage Tolerance	V _{CC} =3.7V	x0.985		x1.015	
$\frac{\Delta V_{OUTN}}{\Delta T}$	V _{OUTN} Voltage Temperature Coefficient	V _{CC} =3.7V, -40°C ≤ Ta ≤ 85°C		± 150		ppm /°C
$\frac{\Delta V_{OUTN}}{\Delta V_{CC}}$	V _{OUTN} Voltage Line Regulation	2.9V ≤ V _{CC} ≤ 3.4		± 6		mV
$\frac{\Delta V_{OUTN}}{\Delta I_{OUT}}$	V _{OUTN} Voltage Load Regulation	V _{CC} =3.7V, 10mA ≤ I _{OUT} ≤ 100mA		± 15		mV
ΔV_{OUTN_TR}	V _{OUTN} Voltage Line Transient Response	V _{CC} =2.9V ↔ 3.4V, T _R =T _F =50us		± 25		mV
Maxduty2	CH2 Max. Duty Cycle	V _{CC} =3.7V	83	90		%
T _{SS2}	CH2 Soft-Start Time	V _{CC} =3.7V		4.5		ms
R _{LXN}	L _{XN} ON Resistance	V _{CC} =3.7V		600		mΩ
I _{OFF LXN}	L _{XN} Leakage Current	V _{CC} =4.8V, V _{LXN} =-6V			5	uA
I _{LIMLXN}	L _{XN} Current Limit	V _{CC} =3.7V	1.0	1.5		A
I _{VOUTN}	V _{OUTN} Discharge Current	V _{CC} =3.7V, V _{OUTN} =-0.3V		50		mA
■ Inverting DC/DC [R1285L00xB]						
V _{FBN}	V _{FBN} voltage tolerance	V _{CC} =3.7V	-25	0	25	mV
I _{FBN}	V _{FBN} input current	V _{CC} =4.8V, V _{FBN} =0V or 4.8V	-0.1		0.1	μA
V _{REF}	V _{REF} voltage tolerance	V _{CC} =3.7V	1.172 +V _{FBN}	1.2 +V _{FBN}	1.228 +V _{FBN}	V
$\frac{\Delta V_{REF}}{\Delta T}$	V _{REF} voltage temperature coefficient	V _{CC} =3.7V -40°C ≤ Ta ≤ 85°C		± 150		ppm /°C
$\frac{\Delta V_{OUTN}}{\Delta V_{CC}}$	V _{OUTN} Voltage Line Regulation	2.9V ≤ V _{CC} ≤ 3.4		± 6		mV
$\frac{\Delta V_{OUTN}}{\Delta I_{OUT}}$	V _{OUTN} Voltage Load Regulation	V _{CC} =3.7V, 10mA ≤ I _{OUT} ≤ 100mA		± 15		mV
ΔV_{OUTN_TR}	V _{OUTN} Voltage Line Transient Response	V _{CC} =2.9V ↔ 3.4V, T _R =T _F =50us		± 25		mV
Maxduty2	CH2 Max. Duty Cycle	V _{CC} =3.7V	83	90		%
T _{SS2}	CH2 Soft-Start Time	V _{CC} =3.7V		4.5		ms
R _{LXN}	L _{XN} ON Resistance	V _{CC} =3.7V		600		mΩ
I _{OFF LXN}	L _{XN} Leakage Current	V _{CC} =4.8V, V _{LXN} =-6V			5	uA
I _{LIMLXN}	L _{XN} Current Limit	V _{CC} =3.7V	1.0	1.5		A
I _{VOUTN}	V _{OUTN} Discharge Current	V _{CC} =3.7V, V _{OUTN} =-0.3V		50		mA

* In terms of TST pin(TST1 , TST2), connect the GND level or remain it open.

TYPICAL APPLICATION AND TECHNICAL NOTES

●R1285LxxxA

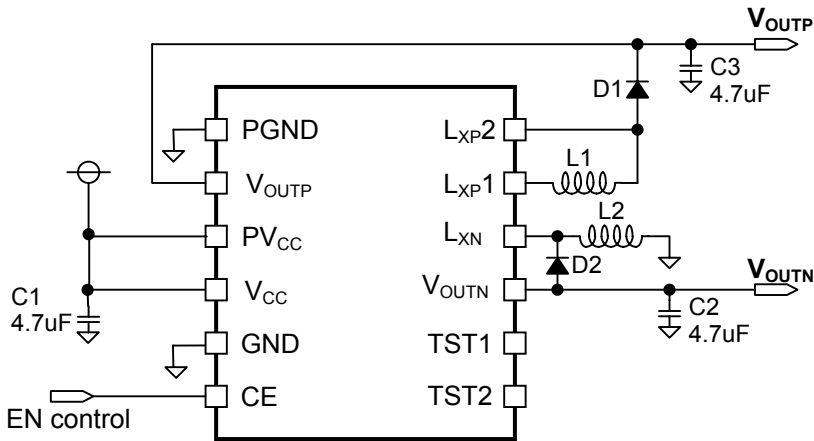

●R1285L00xB

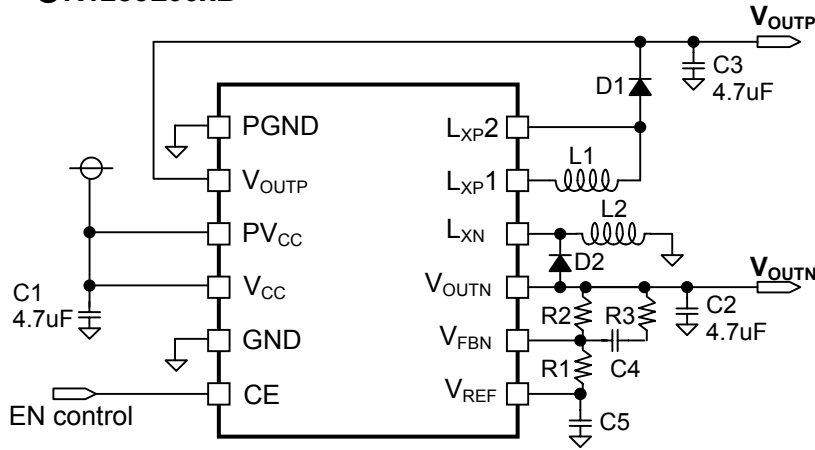

●Set a ceramic 4.7µF or more capacitor between Vcc and GND as C1.

●Set a ceramic 4.7µF or more capacitor between V_{OUTP} and GND, and between V_{OUTN} and GND for each as C2 and C3.

●Start up Sequence

When CE level turns from 'L' to 'H' level, the softstart of CH1 starts the operation. After detecting output voltage of CH1(V_{OUTP}) as the nominal level, the soft start of CH2 starts the operation.

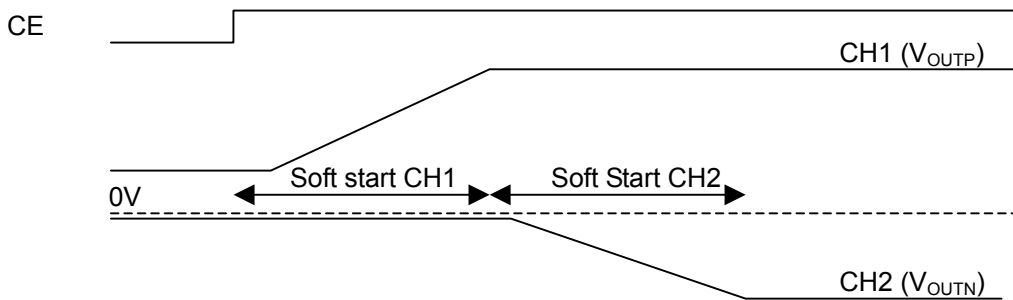

●Auto Discharge Function

When CE level turns from 'H' to 'L' level, the R1285 goes into standby mode and switching of the outputs of L_{XP2} and L_{XN} will stop. Then discharge switch between V_{OUTN} and PV_{CC} and switch between V_{OUTP} and GND turn on and discharge the negative output voltage and positive output voltage. When the negative output voltage is discharged to 0V, the switch between V_{OUTN} and PV_{CC} turns off and the negative output will be Hi-Z. Positive output voltage is discharged to 0V In standby mode.

If V_{CC} voltage became lower than UVLO detect voltage, discharge switches also turn on and discharge output voltage (V_{OUTN} and V_{OUTP}).

In case of timer latch protection, discharge switches will keep off.

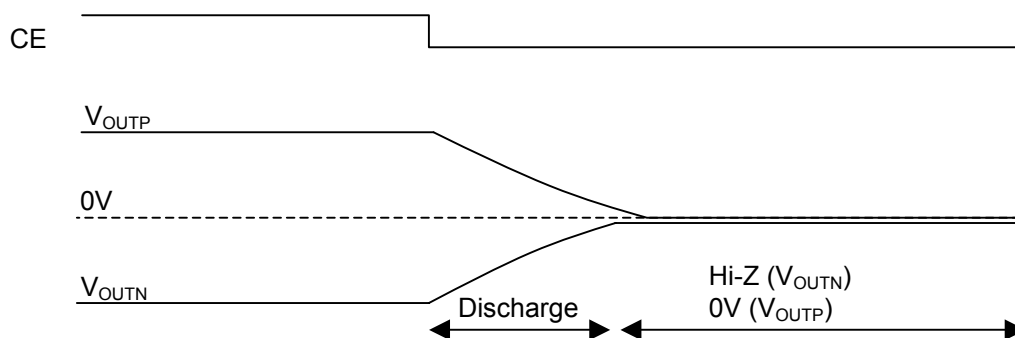

●Short protection circuit timer

In case that the voltage of V_{OUTP} drops, the error amplifier of CH1 outputs "H". In case that the voltage of V_{OUTN} rises, the error amplifier of CH2 outputs "L". The built-in short protection circuit makes the internal timer operate with detecting the output of the error amplifier of CH1 as "H", or the output of the error amplifier of CH2 as "L". After the setting time will pass, the switching of L_{XP2} and L_{XN} will stop and shutdown switch will turn off and both of discharge switches will keep off.

To release the latch operation, make the V_{CC} set equal or less than UVLO level and restart or set the CE pin as "L" and make it "H" again.

During the softstart operation of CH1 and CH2, the timer operates independently from the outputs of the error amplifiers. Therefore, even if the softstart cannot finish correctly because of the short circuit, the protection timer function will be able to work correctly.

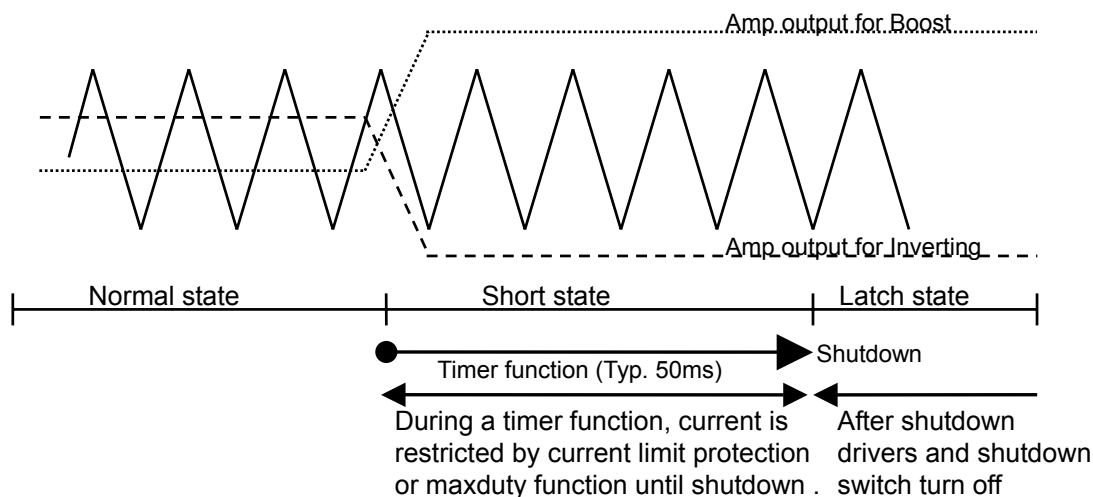

● Inverting DC/DC converter output voltage setting [R1285L00xB]

The output voltage V_{OUTN} of the inverting DC/DC converter is controlled with maintaining the V_{FBN} as 0V. V_{OUTN} can be set with adjusting the values of R1 and R2 as in the next formula.

$$V_{OUTN} = V_{FBN} - (V_{REF} - V_{FBN}) \times R2 / R1$$

DC/DC converter's phase may lose 180 degree by external components of L and C and load current. Because of this, the phase margin of the system will be less and the atability will be worse. Therefore, the pahse must be gaind.

A pole will be formed by external components, L and C.

$$F_{pole} \sim 1 / \{2 \times \pi \times \sqrt{(L2 \times C2)}\}$$

Zero will be formed with R2 and C4.

$$F_{zero} \sim 1 / (2 \times \pi \times R2 \times C4)$$

Set the cutt-off frequency of the Zero close to the cutt-off frequency of the pole by L and C.

If the noise of the system is large, the output noise affects the feedback and the operation may be unstable. In that case, another resistor R3 will be set. The appropriate value range is from 1kΩ to 5kΩ.

● Set a ceramic 1μF to 2.2μF capacitor between V_{REF} and GND as C5. [R1285L00xB]

Operation of Step-up DC/DC Converter and Output Current

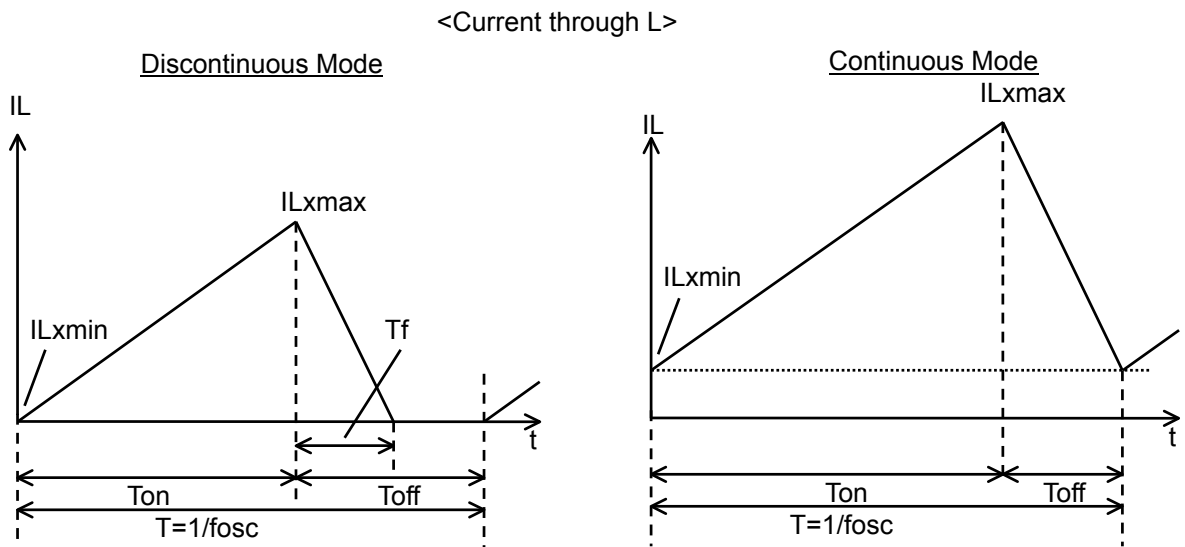
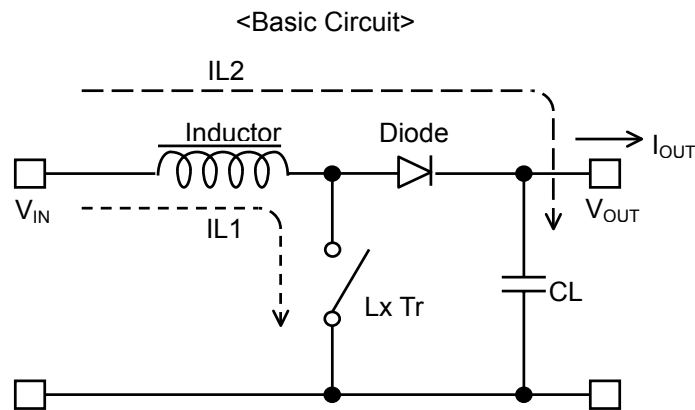

There are two operation modes for the PWM control step-up switching regulator, that is the continuous mode and the discontinuous mode.

When the LX Tr. is on, the voltage for the inductor L will be V_{IN} . The inductor current ($IL1$) will be;
 $IL1 = V_{IN} \times T_{on} / L$ Formula1

When the Lx transistor turns off, power will supply continuously. The inductor current at off ($IL2$) will be;
 $IL2 = (V_{OUT}-V_{IN}) \times T_{f} / L$ Formula2

In terms of the PWM control, when the $T_f=T_{off}$, the inductor current will be continuous, the operation of the switching regulator will be continuous mode.

In the continuous mode, the current variation of $IL1$ and $IL2$ are same, therefore
 $V_{IN} \times T_{on} / L = (V_{OUT}-V_{IN}) \times T_{off} / L$ Formula3

In the continuous mode, the duty cycle will be
 $DUTY = T_{on} / (T_{on}+T_{off}) = (V_{OUT}-V_{IN}) / V_{OUT}$ Formula4

If the input power equals to output power,
 $I_{OUT} = V_{IN}^2 \times T_{on} / (2 \times L \times V_{OUT})$ Formula5

When I_{OUT} becomes more then Formula5, it will be continuous mode.

In this moment, the peak current, IL_{xmax} flowing through the inductor is described as follows:

$$IL_{xmax} = I_{OUT} \times V_{OUT} / V_{IN} + V_{IN} \times T_{on} / (2 \times L) \text{Formula6}$$

$$IL_{xmax} = I_{OUT} \times V_{OUT} / V_{IN} + V_{IN} \times T_x (V_{OUT}-V_{IN}) / (2 \times L \times V_{OUT}) \text{Formula7}$$

Therefore, peak current is more than I_{OUT} . Considering the value of IL_{xmax} , the condition of input and output, and external components should be selected.

The explanation above is based on the ideal calculation, and the loss caused by Lx switch and external components is not included.

The actual maximum output current is between 50% and 80% of the calculation.

Especially, when the IL is large, or V_{IN} is low, the loss of V_{IN} is generated with on resistance of the switch.

As for V_{OUT} , V_F (as much as 0.3V)of the diode should be considered.

Operation of Inverting DC/DC Converter and Output Current

<Basic Circuit>

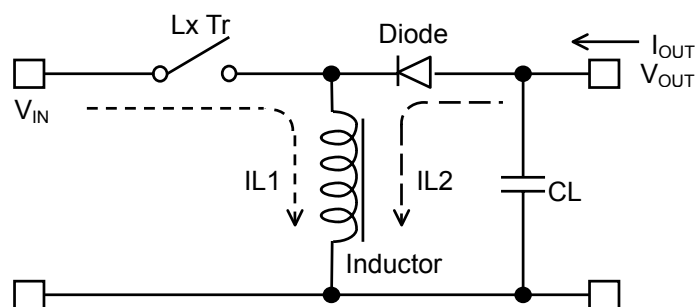

<Current through L>

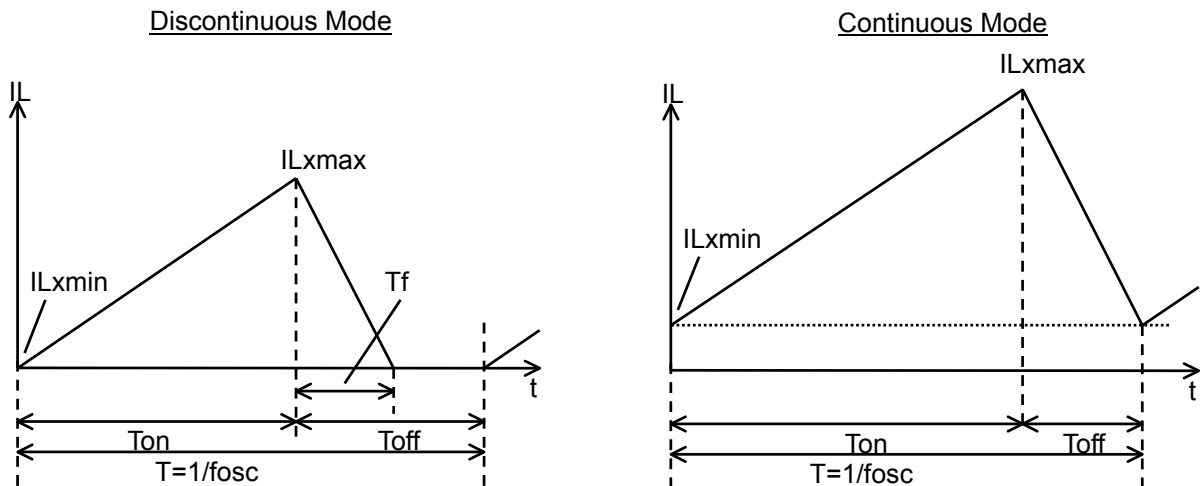

There are also two operation modes for the PWM control inverting switching regulator, that is the continuous mode and the discontinuous mode.

When the LX Tr. is on, the voltage for the inductor L will be VIN. The inductor current (IL1) will be;

$$IL1 = V_{IN} \times T_{on} / L \dots \dots \dots \text{Formula8}$$

Inverting circuit saves energy during on time of Lx Tr, and supplies the energy to output during off time, output voltage opposed to input voltage is obtained. The inductor current at off (IL2) will be;

$$IL2 = V_{OUT} \times T_f / L \dots \dots \dots \text{Formula9}$$

(The above formula and after, the absolute value of the negative output voltage is assumed to be VOUT. : Output voltage= -10V, VOUT=10)

In terms of the PWM control, when the Tf=Toff, the inductor current will be continuous, the operation of the switching regulator will be continuous mode.

In the continuous mode, the current variation of IL1 and IL2 are same, therefore

$$V_{IN} \times T_{on} / L = V_{OUT} \times T_{off} / L \dots \dots \dots \text{Formula10}$$

In the continuous mode, the duty cycle will be:

$$\text{DUTY} = T_{on} / (T_{on} + T_{off}) = V_{OUT} / (V_{OUT} + V_{IN}) \dots \dots \dots \text{Formula11}$$

If the input power equals to output power,

$$I_{OUT} = V_{IN}^2 \times T_{on} / (2 \times L \times V_{OUT}) \dots \dots \dots \text{Formula12}$$

When IOUT becomes more then Formula12 , it will be continuous mode.

In this moment ,the peak current, ILxmax flowing through the inductor is described as follows:

$$IL_{xmax} = I_{OUT} \times V_{OUT} / V_{IN} + V_{IN} \times T_{on} / (2 \times L) \dots \dots \dots \text{Formula13}$$

$$IL_{xmax} = I_{OUT} \times V_{OUT} / V_{IN} + V_{IN} \times V_{OUT} \times T / \{ 2 \times L \times (V_{OUT} + V_{IN}) \} \dots \dots \dots \text{Formula14}$$

Therefore, peak current is more than IOUT. Considering the value of ILxmax, the condition of input and output, and external components should be selected.

The explanation above is based on the ideal calculation, and the loss caused by Lx switch and external components is not included.

The actual maximum output current is between 50% and 80% of the calculation.

Especially, when the IL is large, or VIN is low, the loss of VIN is generated with on resistance of the switch. As for VOUT, VF(as much as 0.3V)of the diode should be considered.