

OUTLINE

The R1283X 2ch DC/DC converter is designed for CCD & OLED Display power source. It contains a step up DC/DC converter and an inverting DC/DC converter to generate two required voltages by CCD & OLED Display. Step up DC/DC converter generates boosted output voltage up to 20V. Inverting DC/DC converter generates negative voltage up to V_{in} voltage minus 20V independently. Start up sequence is internally made. Each of the R1283X series consists of an oscillator, a PWM control circuit, a voltage reference, error amplifiers, over current protection circuits, short protection circuits, an under voltage lockout circuit (UVLO), an Nch driver for boost operation, a Pch driver for inverting, and so on. A high efficiency boost and inverting DC/DC converter can be composed with external inductors, diodes, capacitors, and resistors.

FEATURES

- Operating Voltage ***** 2.5V ~ 5.5V
- Step Up DC/DC (CH1)
 - Internal Nch MOSFET Driver ($R_{on}=400m\Omega$ Typ.)
 - Adjustable Vout Up to 20V with external resistor
 - Internal Soft start function (Typ. 4.5ms)
 - Over Current Protection
 - Maximum Duty Cycle: 91%(Typ.)
- Inverting DC/DC (CH2)
 - Internal Pch MOSFET Driver ($R_{on}=400m\Omega$ Typ.)
 - Adjustable Vout Up to $V_{dd}-20V$ with external resistor
 - Auto Discharge function for negative output
 - Internal Soft start function (Typ. 4.5ms)
 - Over Current Protection
 - Maximum Duty Cycle: 91%(Typ.)
- Short Protection with timer latch function (Typ. 50ms); Short condition for either or both two outputs makes all output drivers off and latches./ If the maximum duty cycle continues for a certain time, these output drivers will be turned off.
 - CE with start up sequence function
 - CH1→CH2 (R1283K001X)/CH2→CH1(R1283K002X) Selectable
 - UVLO function.
 - Operating Frequency Selection ***** 300kHz / 700kHz / 1400kHz
- Small package ***** DFN(PLP)12 (2.7mm x 3.0mm) or WLCSP11(1.5mm x 2.4mm)

APPLICATION

- Fixed voltage power supply for portable equipment
- Fixed voltage power supply for CCD,OLED,LCD

BLOCK DIAGRAM

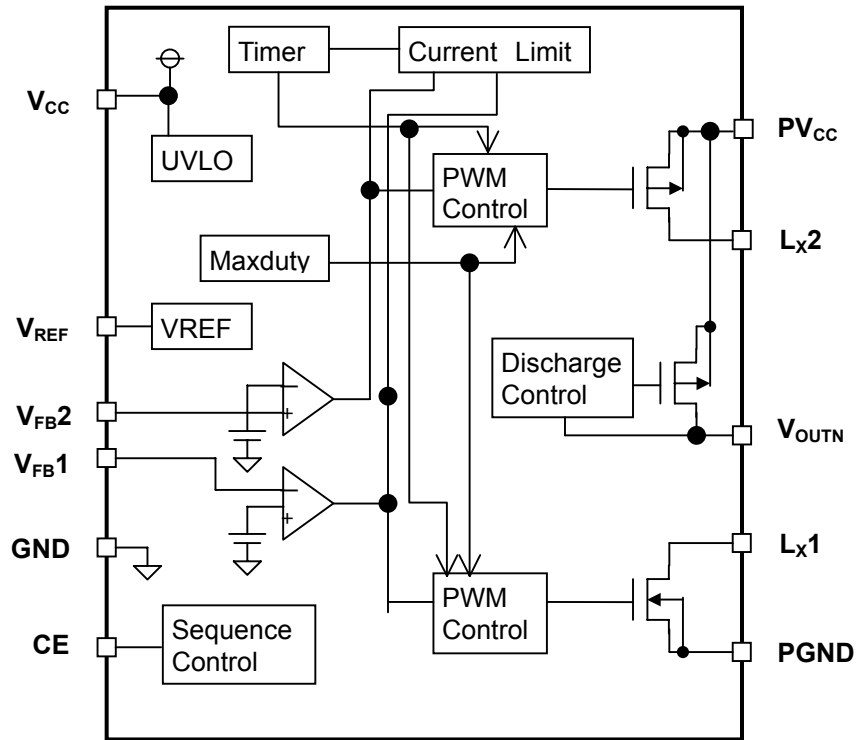

SELECTION GUIDE

The mask option for the ICs can be selected at the user's request. The selection can be made with designating the part number as shown below.

R 1 2 8 3 X 0 0 X X - X X ← Part Number
 ↓ ↓ ↓ ↓
 a b c d

code	contents
a	Designation of Package Type K: DFN(PLP)-2730-12 Z: WLCSP11
b	Designation of Start-up Sequence 1: first CH1, second CH2. 2: first CH2, second CH1.
c	Designation of Oscillator Frequency A: 300kHz, B: 700kHz, C: 1400kHz
d	Designation of Taping Type TR: DFN(PLP)-2730-12 E2: WLCSP11

*1: The WLCSP11 package of the oscillation frequency 300kHz is being developed.

PIN CONFIGURATION

● DFN(PLP)-2730-12

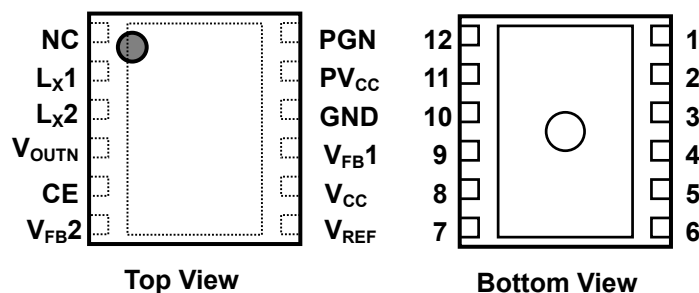

● WLCSP-11

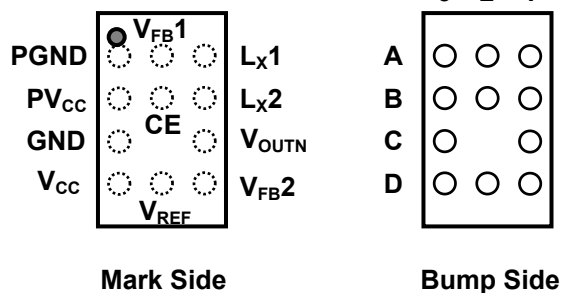

PIN DESCRIPTIONS

DFN(PLP)

PIN No.	NAME	FUNCTION
1	NC	No Connect
2	L _x 1	Switching pin for Step up DC/DC
3	L _x 2	Switching pin for Inverting DC/DC
4	V _{OUTN}	Discharge pin for Negative output
5	CE	Chip enable pin for the R1283
6	V _{FB} 2	Feedback pin for Inverting DC/DC
7	V _{REF}	Reference voltage output pin
8	V _{CC}	Analog power source input pin
9	V _{FB} 1	Feedback pin for Step up DC/DC
10	GND	Analog GND pin
11	PV _{CC}	Power input pin
12	PGND	Power GND pin

WLCSP

PIN No.	NAME	FUNCTION
A1	PGND	Power GND pin
A2	V _{FB} 1	Feedback pin for Step up DC/DC
A3	L _x 1	Switching pin for Step up DC/DC
B1	PV _{CC}	Power input pin
B2	CE	Chip enable pin for the R1283
B3	L _x 2	Switching pin for Inverting DC/DC
C1	GND	Analog GND pin
C3	V _{OUTN}	Discharge pin for Negative output
D1	V _{CC}	Analog power source input pin
D2	V _{REF}	Reference voltage output pin
D3	V _{FB} 2	Feedback pin for Inverting DC/DC

ABSOLUTE MAXIMUM RATINGS

(GND / PGND=0V)

Item	Symbol	Rating	Unit
V _{CC} / PV _{CC} pin Voltage	V _{CC}	6.5	V
V _{FR1} pin Voltage	V _{DTC}	-0.3~V _{CC} +0.3	V
V _{FR2} pin Voltage	V _{FR}	-0.7(*1)~V _{CC} +0.3	V
CE pin Voltage	V _{CE}	-0.3~V _{CC} +0.3	V
V _{REF} pin Voltage	V _{REF}	-0.7(*1)~V _{CC} +0.3	V
L _{X1} pin Voltage	V _{LX1}	-0.3~24	V
L _{X1} pin Current	I _{LX1}	Internally Limited	A
L _{X2} pin Voltage	V _{LX2}	V _{CC} -24 ~ V _{CC} +0.3	V
L _{X2} pin Current	I _{LX2}	Internally Limited	A
V _{OUTN} pin Voltage	V _{NFR}	V _{CC} -24 ~ V _{CC} +0.3	V
Power Dissipation	PD	1000	mW
Operating Temperature Range	Topt	-40 ~ +85	°C
Storage Temperature Range	Tstg	-55 ~ +125	°C

*1: In case the voltage range is from -0.7V to -0.3V, permissible current is 10mA or less.

ABSOLUTE MAXIMUM RATINGS

Absolute Maximum ratings are threshold limit values that must not be exceeded ever for an instant under any conditions. Moreover, such values for any two items must not be reached simultaneously. Operation above these absolute maximum ratings may cause degradation or permanent damage to the device. These are stress ratings only and do not necessarily imply functional operation these limits.

ELECTRICAL CHARACTERISTICS

(Topt=25°C)

Symbol	Item	Conditions	MIN.	TYP.	MAX.	Unit.
V _{CC}	Operating Input Voltage		2.5		5.5	V
I _{CC1}	V _{CC} consumption current (switching)	V _{CC} =5.5V , FREQ=300kHz		2.0		mA
		V _{CC} =5.5V , FREQ=700kHz		4.0		mA
		V _{CC} =5.5V , FREQ =1400 kHz		8.0		mA
I _{CC2}	V _{CC} consumption current (at no switching)	V _{CC} =5.5V , FREQ=300kHz		250		uA
		V _{CC} =5.5V , FREQ=700kHz		300		uA
		V _{CC} =5.5V , FREQ =1400 kHz		350		uA
I _{STB}	Standby current	V _{CC} =5.5V		0.1	3	uA
V _{UVLO1}	UVLO detect voltage	Falling	2.05	2.15	2.25	V
V _{UVLO2}	UVLO released voltage	Rising		V _{UVLO1} +0.16	2.48	V
V _{REF}	V _{REF} voltage tolerance	V _{CC} =3.3V	1.172	1.2	1.228	V
ΔV _{REF} /ΔT	V _{REF} voltage temperature coefficient	V _{CC} =3.3V -40°C ≤ Topt ≤ 85°C		±150		Ppm /°C
ΔV _{REF} /ΔV _{CC}	V _{REF} Line regulation	2.5 ≤ V _{CC} ≤ 5.5V		5		mV

$\Delta V_{REF} / \Delta I_{OUT}$	V _{REF} Load regulation	V _{CC} =3.3V 0.1mA ≤ I _{OUT} ≤ 2mA		5		mV
I _{LIMREF}	V _{REF} short current limit	V _{CC} =3.3V , V _{REF} =0V		15		mA
V _{FBI}	V _{FBI} voltage tolerance	V _{CC} =3.3V	0.985	1.0	1.015	V
$\Delta V_{FB1} / \Delta T$	V _{FBI} voltage temperature coefficient	V _{CC} =3.3V -40°C ≤ T _{opt} ≤ 85°C		±150		Ppm /°C
I _{FB1}	V _{FBI} input current	V _{CC} =5.5V , V _{FBI} =0V or 5.5V	-0.1		0.1	μA
V _{FB2}	V _{FB2} voltage tolerance	V _{CC} =3.3V	-25	0	25	mV
I _{FB2}	V _{FB2} input current	V _{CC} =5.5V , V _{FB2} =0V or 5.5V	-0.1		0.1	μA
F _{osc}	Oscillator frequency	V _{CC} =3.3V	240	300	360	kHz
		V _{CC} =3.3V	600	700	800	kHz
		V _{CC} =3.3V	1200	1400	1600	kHz
Maxduty1	CH1 Max. Duty cycle	V _{CC} =3.3V	86	91		%
Maxduty2	CH2 Max. Duty cycle	V _{CC} =3.3V	86	91		%
T _{SS1}	CH1 soft start time	V _{CC} =3.3V , V _{FBI} =0.9V		4.5		ms
T _{SS2}	CH2 soft start time	V _{CC} =3.3V , V _{FB2} =0.12V		4.5		ms
T _{DLY}	Delay time for protection	V _{CC} =3.3V	20	50		ms
R _{LX1}	LX1 ON resistance	V _{CC} =3.3V		400		mΩ
I _{OFF LX1}	LX1 Leakage current	V _{CC} =5.5V , V _{LX1} =20V			5	uA
I _{LIMLX1}	LX1 current limit	V _{CC} =3.3V	1.0	1.5		A
R _{LX2}	LX2 ON resistance	V _{CC} =3.3V		400		mΩ
I _{OFF LX2}	LX2 Leakage current	V _{CC} =5.5V , V _{LX} =-14.5V			5	uA
I _{LIMLX2}	LX2 current limit	V _{CC} =3.3V	1.0	1.5		A
I _{VOUTN}	V _{OUTN} Discharge current	V _{CC} =3.3V , V _{OUTN} =-0.3V		10	25	Ω
V _{CEL}	CE “L” input voltage	V _{CC} =2.5V			0.3	V
V _{CEH}	CE “H” input voltage	V _{CC} =5.5V	1.5			V
I _{CEL}	CE “L” input current	V _{CC} =5.5V	-1.0		1.0	uA
I _{CEH}	CE “H” input current	V _{CC} =5.5V	-1.0		1.0	uA

TYPICAL APPLICATION

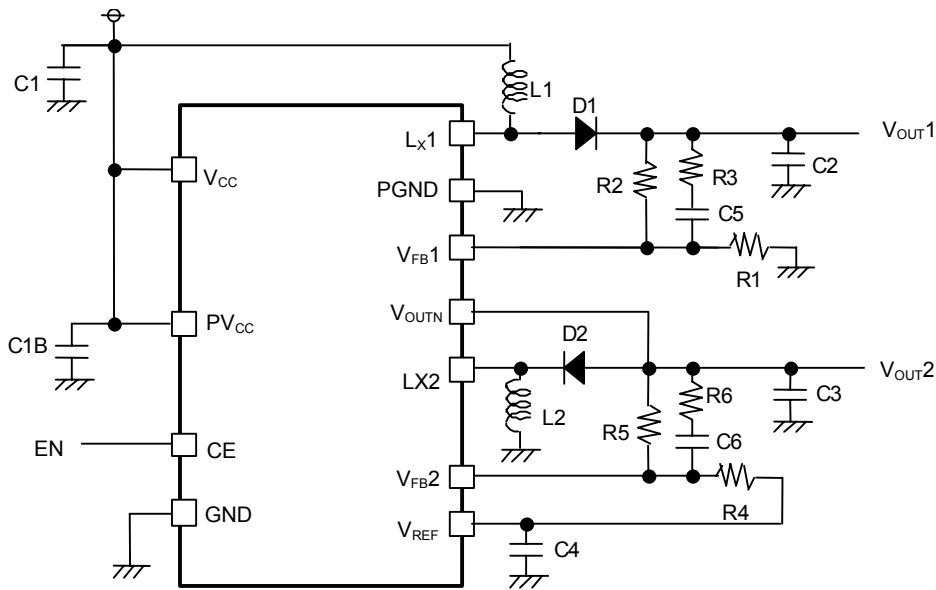

● Step-up DC/DC converter output voltage setting

The output voltage V_{OUT1} of the step-up DC/DC converter is controlled with maintaining the V_{FB1} as 1.0V. V_{OUT1} can be set with adjusting the values of $R1$ and $R2$ as in the next formula. V_{OUT1} can be set equal or less than 20V.

$$V_{OUT1} = V_{FB1} \times (R1+R2) / R1$$

● Inverting DC/DC converter output voltage setting

The output voltage V_{OUT2} of the inverting DC/DC converter is controlled with maintaining the V_{FB2} as 0V. V_{OUT2} can be set with adjusting the values of $R4$ and $R5$ as in the next formula.

$$V_{OUT2} = V_{FB2} - (V_{REF}-V_{FB2}) \times R5 / R4$$

● Auto Discharge Function

When CE level turns from 'H' to 'L' level, the R1283 goes into standby mode and switching of the outputs of LX1 and LX2 will stop. Then discharge T_r between V_{OUT2} and V_{CC} turns on and discharges the negative output voltage. When the negative output voltage is discharged to 0V, the T_r turns off and the negative output will be Hi-Z.

When the Auto discharge function is unnecessary, V_{OUTN} connect to V_{CC} or make be Hi-Z.

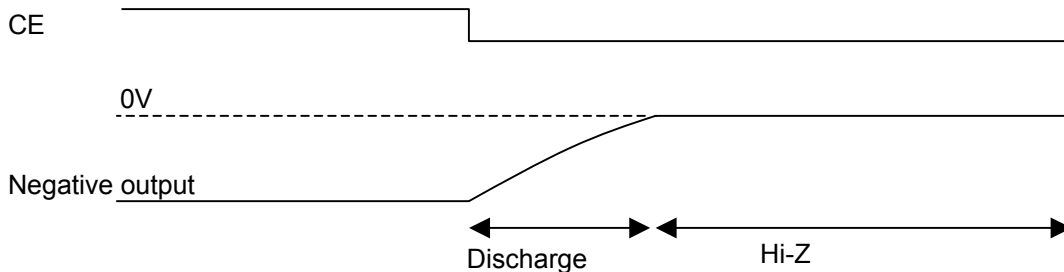

- Start up Sequence (R1283X001x)

When CE level turns from 'L' to 'H' level, the softstart of CH1 starts the operation. After detecting output voltage of CH1 (V_{OUT1}) as the nominal level, the soft start of CH2 starts the operation.

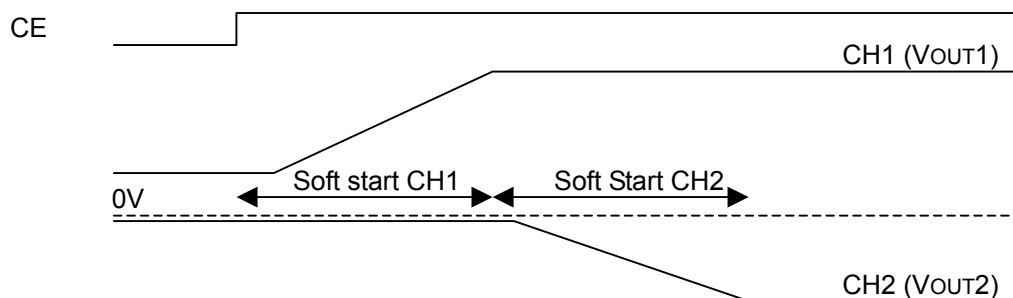

- Start up Sequence (R1283X002x)

When CE level turns from 'L' to 'H' level, the softstart of CH2 starts the operation. After detecting output voltage of CH2 (V_{OUT2}) as the nominal level, the soft start of CH1 starts the operation.

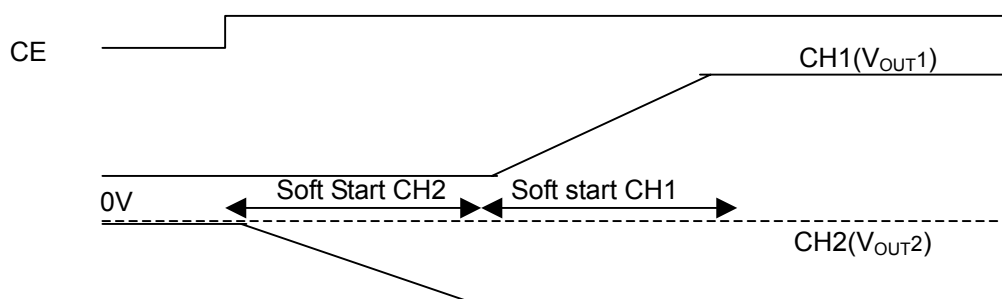

- Short protection circuit timer

In case that the voltage of V_{FB1} drops, the error amplifier of CH1 outputs "H". In case that the voltage of V_{FB2} rises, the error amplifier of CH2 outputs "L". The built-in short protection circuit makes the internal timer operate with detecting the output of the error amplifier of CH1 as "H", or the output of the error amplifier of CH2 as "L". After the setting time will pass, the switching of LX1 and LX2 will stop.

To release the latch operation, make the V_{cc} set equal or less than UVLO level and restart or set the CE pin as "L" and make it "H" again.

During the softstart operation of CH1 and CH2, the timer operates independently from the outputs of the error amplifiers. Therefore, even if the softstart cannot finish correctly because of the short circuit, the protection timer function will be able to work correctly.

- Phase Compensation of step-up DC/DC converter

DC/DC converter's phase may lose 180 degree by external components of L and C and load current. Because of this, the phase margin of the system will be less and the stability will be worse. Therefore, the phase must be gained.

A pole will be formed by external components, L and C.

$$F_{\text{pole}} \sim 1 / \{2 \times \pi \times \sqrt{(L1 \times C2)}\} \quad (\text{CH1})$$

$$F_{\text{pole}} \sim 1 / \{2 \times \pi \times \sqrt{(L2 \times C3)}\} \quad (\text{CH2})$$

Zero will be formed with R2, C5, R5, and C6.

$$F_{\text{zero}} \sim 1 / (2 \times \pi \times R2 \times C5) \quad (\text{CH1})$$

$$F_{\text{zero}} \sim 1 / (2 \times \pi \times R5 \times C6) \quad (\text{CH2})$$

Set the cut-off frequency of the Zero lower than the cut off frequency of the pole by L and C.

- To reduce the noise of Feedback voltage
If the noise of the system is large, the output noise affects the feedback and the operation may be unstable. In that case, resistor values, R1, R2, R4, and R5 should be set lower and make the noise into the feedback pin reduce. Another method is set R3 and R6 . The appropriate value range is from $1k\Omega$ to $5k\Omega$.
- Set a ceramic $1\mu\text{F}$ or more capacitor as C1B between Vcc pin and GND. Set another $4.7\mu\text{F}$ or more capacitor between PVcc and GND as C1.
- Set a ceramic $1\mu\text{F}$ or more capacitor between VOUT1 and GND, and between VOUT2 and GND for each as C2 and C3. Recommendation value range is from $4.7\mu\text{F}$ to $22\mu\text{F}$.
- Set a ceramic capacitor between VREF and GND as C4. Recommendation value range is from $0.1\mu\text{F}$ to $2.2\mu\text{F}$.

Operation of Step-up DC/DC Converter and Output Current

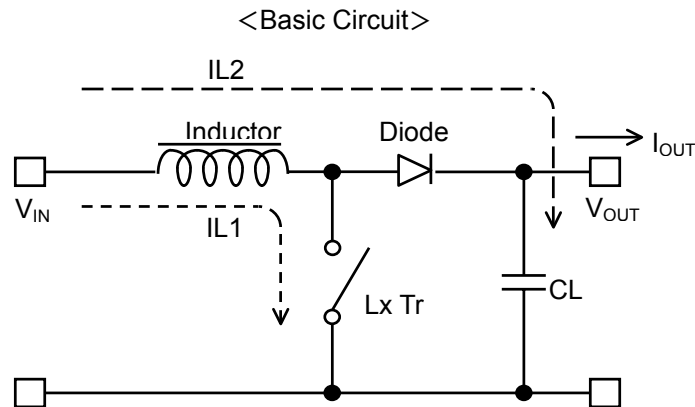

<Current through L>

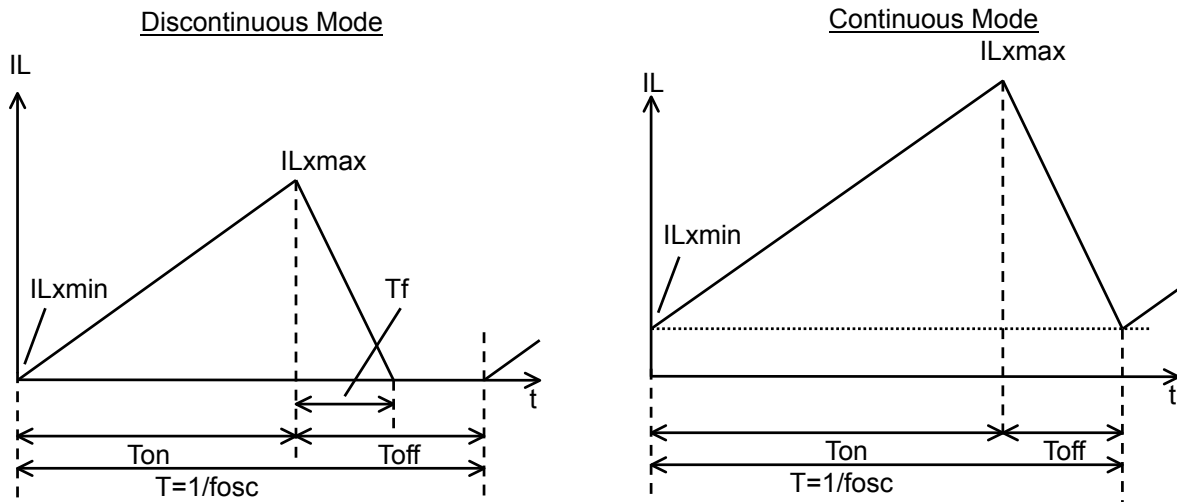

There are two operation modes for the PWM control step-up switching regulator, that is the continuous mode and the discontinuous mode.

When the LX Tr. is on, the voltage for the inductor L will be V_{IN} . The inductor current (I_{L1}) will be;

$$I_{L1} = V_{IN} \times T_{on} / L \dots\dots\dots \text{Formula1}$$

When the Lx transistor turns off, power will supply continuously. The inductor current at off (I_{L2}) will be;

$$I_{L2} = (V_{OUT} - V_{IN}) \times T_f / L \dots\dots\dots \text{Formula2}$$

In terms of the PWM control, when the $T_f = T_{off}$, the inductor current will be continuous, the operation of the switching regulator will be continuous mode.

In the continuous mode, the current variation of I_{L1} and I_{L2} are same, therefore

$$V_{IN} \times T_{on} / L = (V_{OUT} - V_{IN}) \times T_{off} / L \dots\dots\dots \text{Formula3}$$

In the continuous mode, the duty cycle will be

$$\text{DUTY} = T_{on} / (T_{on} + T_{off}) = (V_{OUT} - V_{IN}) / V_{OUT} \dots\dots\dots \text{Formula4}$$

If the input power equals to output power,

$$I_{OUT} = V_{IN}^2 \times T_{on} / (2 \times L \times V_{OUT}) \dots\dots\dots \text{Formula5}$$

When I_{OUT} becomes more than Formula5, it will be continuous mode.

In this moment, the peak current, I_{Lxmax} flowing through the inductor is described as follows:

$$I_{Lxmax} = I_{OUT} \times V_{OUT} / V_{IN} + V_{IN} \times T_{on} / (2 \times L) \dots\dots\dots \text{Formula6}$$

$$I_{Lxmax} = I_{OUT} \times V_{OUT} / V_{IN} + V_{IN} \times T_x (V_{OUT} - V_{IN}) / (2 \times L \times V_{OUT}) \dots\dots\dots \text{Formula7}$$

Therefore, peak current is more than I_{OUT} . Considering the value of I_{Lxmax} , the condition of input and output, and external components should be selected.

The explanation above is based on the ideal calculation, and the loss caused by Lx switch and external components is not included.

The actual maximum output current is between 50% and 80% of the calculation.

Especially, when the I_L is large, or V_{IN} is low, the loss of V_{IN} is generated with on resistance of the switch. As for V_{OUT} , V_F (as much as 0.3V) of the diode should be considered.

Operation of Inverting DC/DC Converter and Output Current

<Basic Circuit>

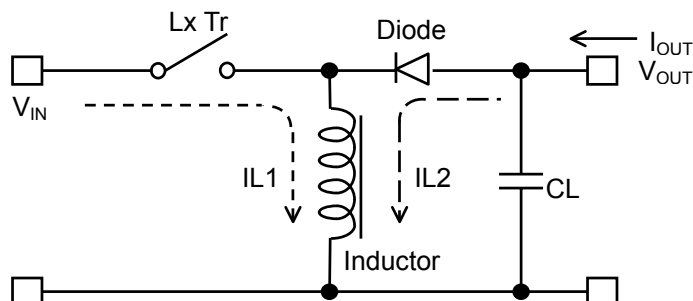

<Current through L>

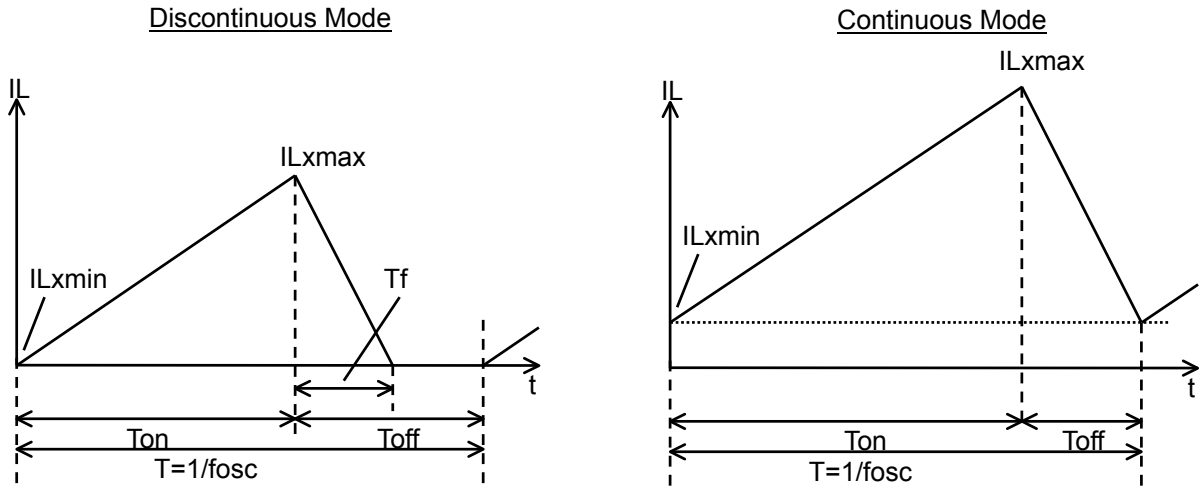

There are also two operation modes for the PWM control inverting switching regulator, that is the continuous mode and the discontinuous mode.

When the LX Tr. is on, the voltage for the inductor L will be VIN. The inductor current (IL1) will be;

$$IL1 = V_{IN} \times T_{on} / L \dots\dots\dots \text{Formula8}$$

Inverting circuit saves energy during on time of Lx Tr, and supplies the energy to output during off time, output voltage opposed to input voltage is obtained. The inductor current at off (IL2) will be;

$$IL2 = V_{OUT} \times T_f / L \dots\dots\dots \text{Formula9}$$

(The above formula and after, the absolute value of the negative output voltage is assumed to be VOUT. :Output voltage= -10V ,VOUT=10)

In terms of the PWM control, when the Tf=Toff, the inductor current will be continuous, the operation of the switching regulator will be continuous mode.

In the continuous mode, the current variation of IL1 and IL2 are same, therefore

$$V_{IN} \times T_{on} / L = V_{OUT} \times T_{off} / L \dots\dots\dots \text{Formula10}$$

In the continuous mode, the duty cycle will be:

$$\text{DUTY} = T_{on} / (T_{on} + T_{off}) = V_{OUT} / (V_{OUT} + V_{IN}) \dots\dots\dots \text{Formula11}$$

If the input power equals to output power,

$$I_{OUT} = V_{IN}^2 \times T_{on} / (2 \times L \times V_{OUT}) \dots\dots\dots \text{Formula12}$$

When IOUT becomes more than Formula12 ,it will be continuous mode.

In this moment ,the peak current,ILxmax flowing through the inductor is described as follows:

$$IL_{xmax} = I_{OUT} \times V_{OUT} / V_{IN} + V_{IN} \times T_{on} / (2 \times L) \dots\dots\dots \text{Formula13}$$

$$IL_{xmax} = I_{OUT} \times V_{OUT} / V_{IN} + V_{IN} \times V_{OUT} \times T / \{ 2 \times L \times (V_{OUT} + V_{IN}) \} \dots\dots\dots \text{Formula14}$$

Therefore,peak current is more than IOUT.Considering the value of ILxmax,the condition of input and output,and external components should be selected.

The explanation above is based on the ideal calculation,and the loss caused by Lx switch and external components is not included.

The actual maximum output current is between 50% and 80% of the calculation.

Especially,when the IL is large,or VIN is low,the loss of VIN is generated with on resistance of the switch.As for VOUT,VF(as much as 0.3V)of the diode should be considered.

TYPICAL CHARACTERISTICS

1) Output Voltage VS. Output Current

R1283x001A

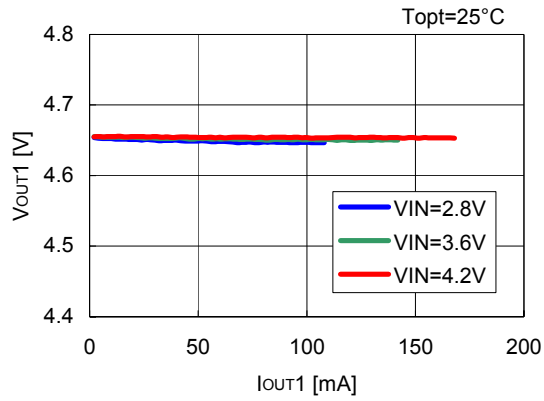

R1283x001A

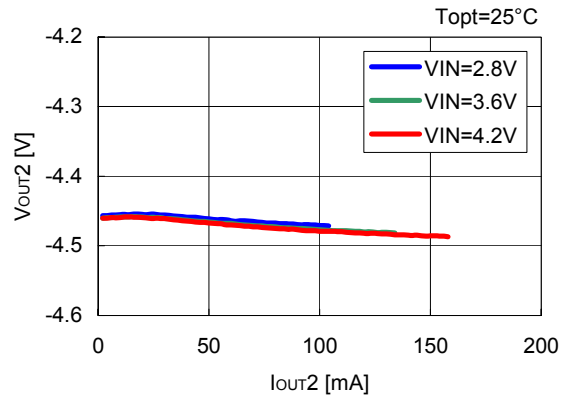

R1283x001A

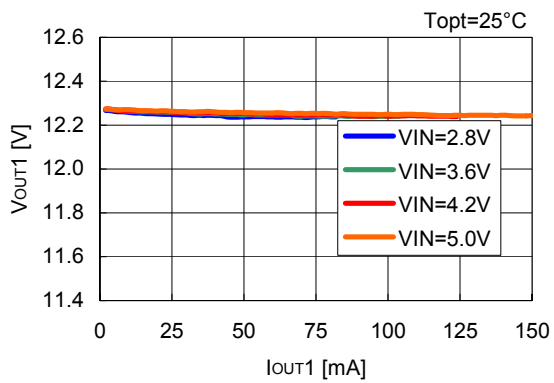

R1283x001A

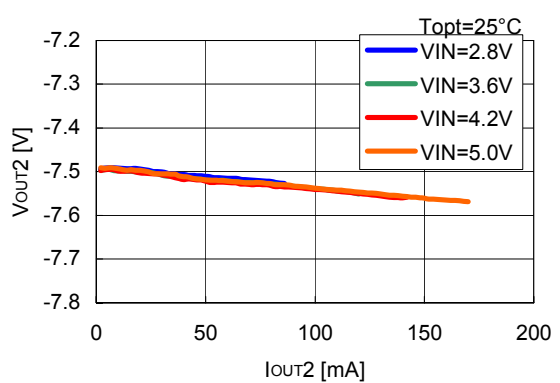

R1283x001B

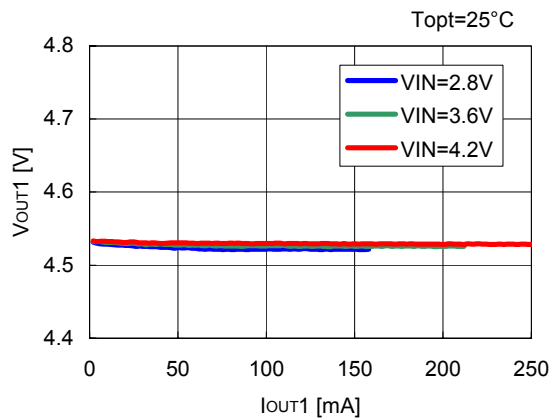

R1283x001B

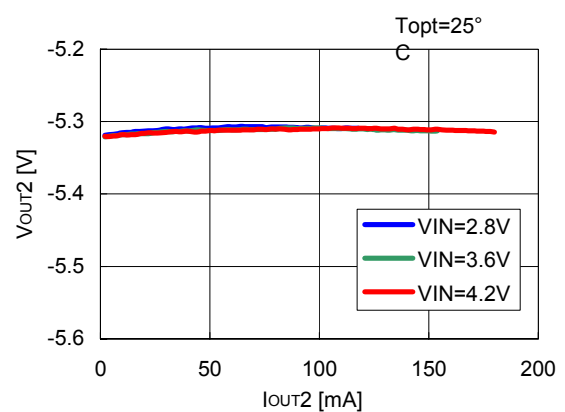

R1283x001B

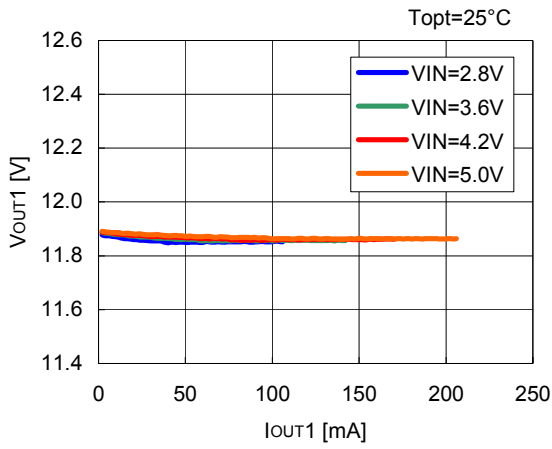

R1283x001B

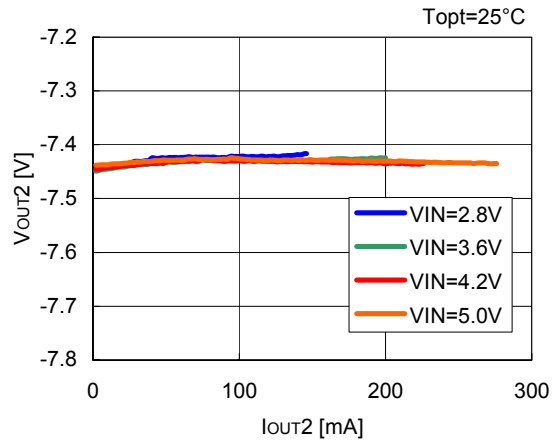

R1283x001C

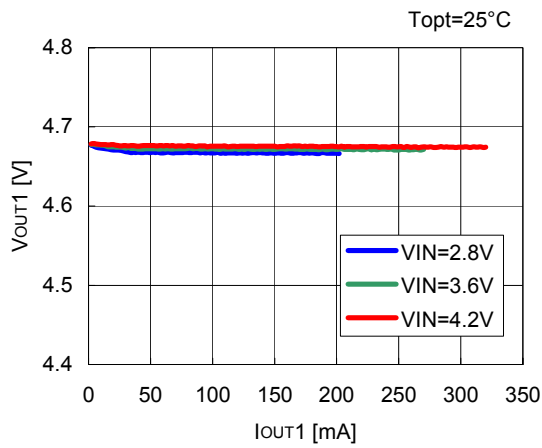

R1283x001C

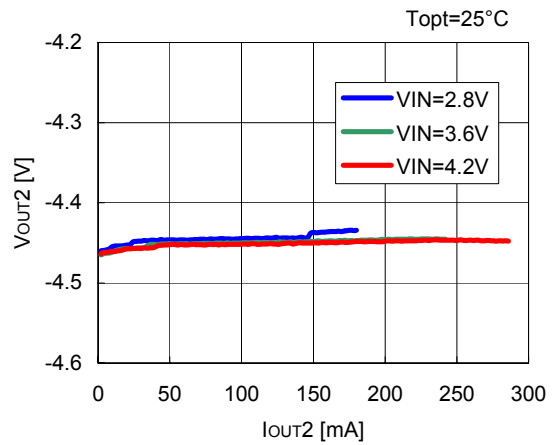

R1283x001C

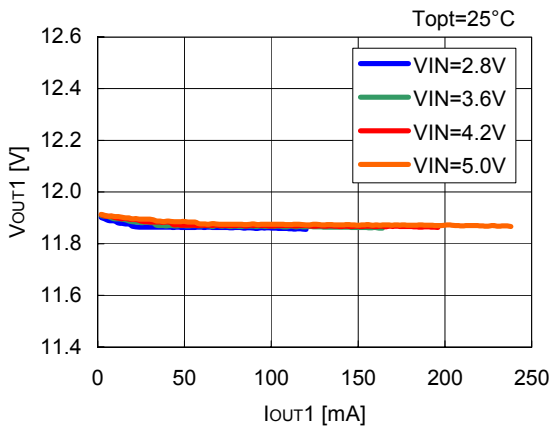

R1283x001C

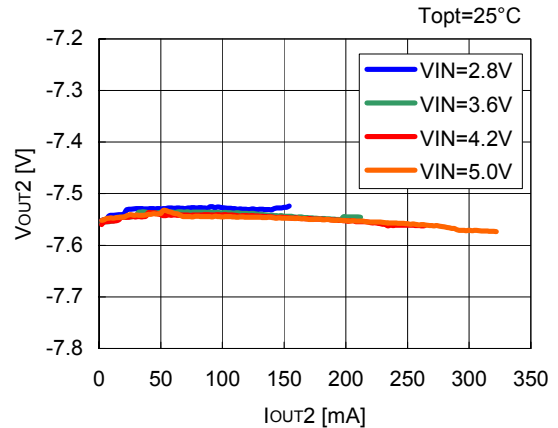

2) Efficiency vs. Output Current

R1283x001A

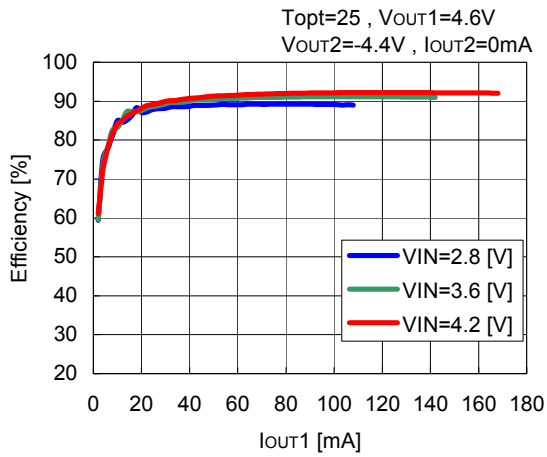

R1283x001A

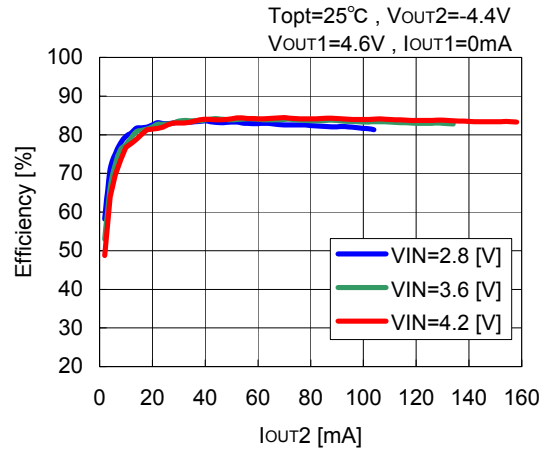

R1283x001A

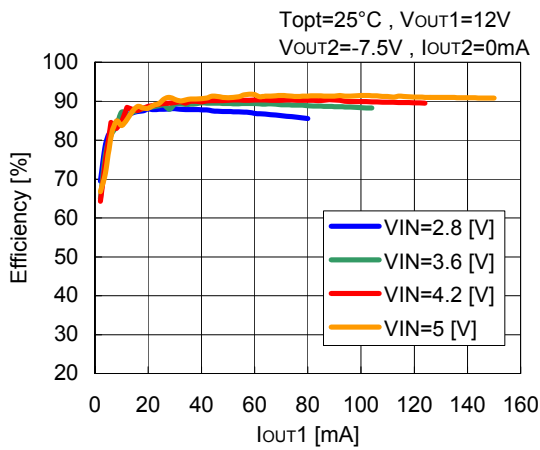

R1283x001A

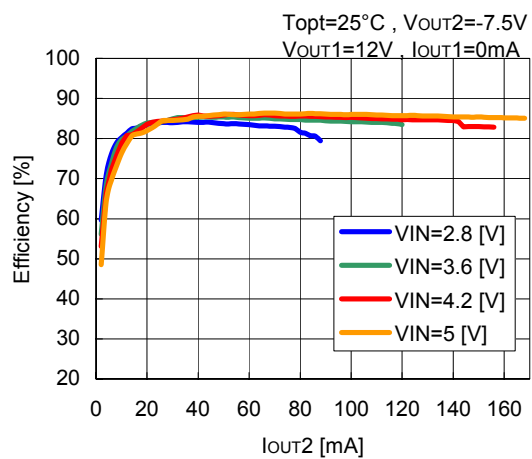

R1283x001B

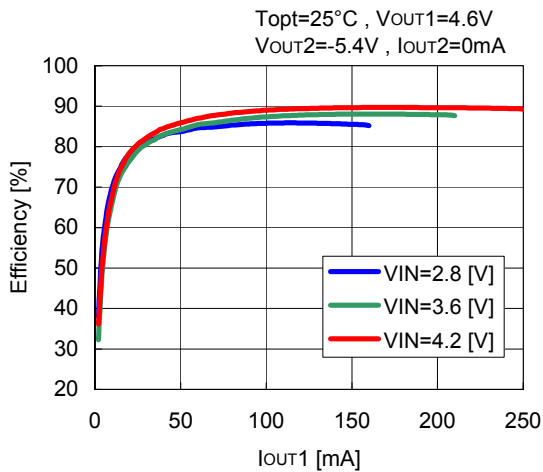

R1283x001B

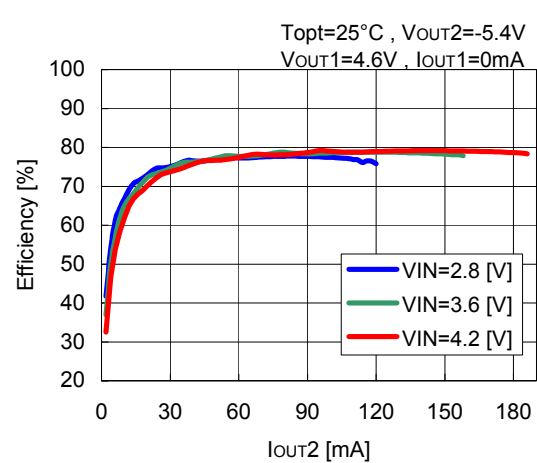

R1283x001B

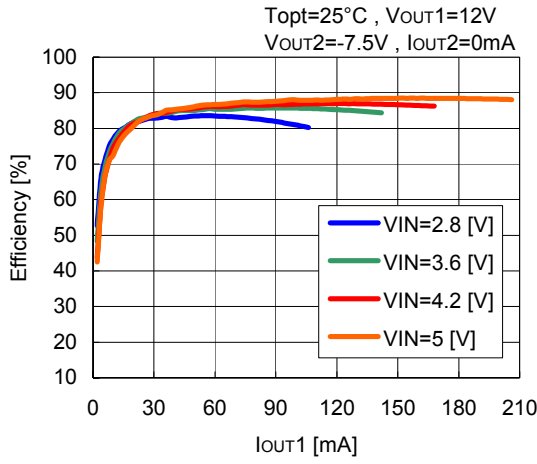

R1283x001B

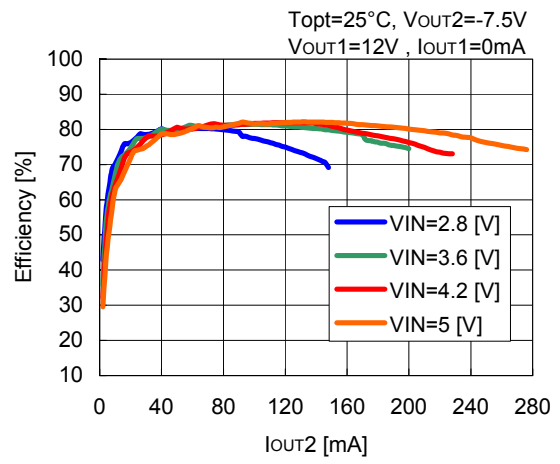

R1283x001C

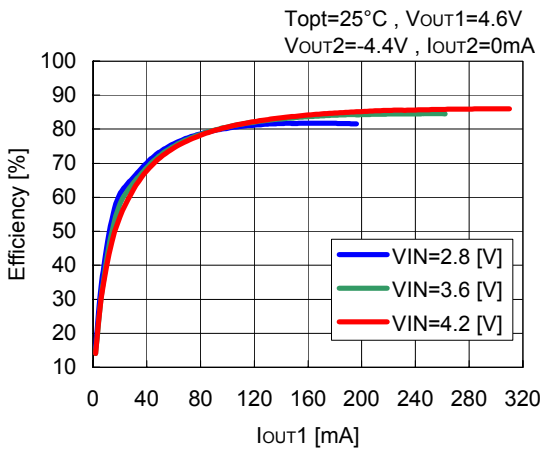

R1283x001C

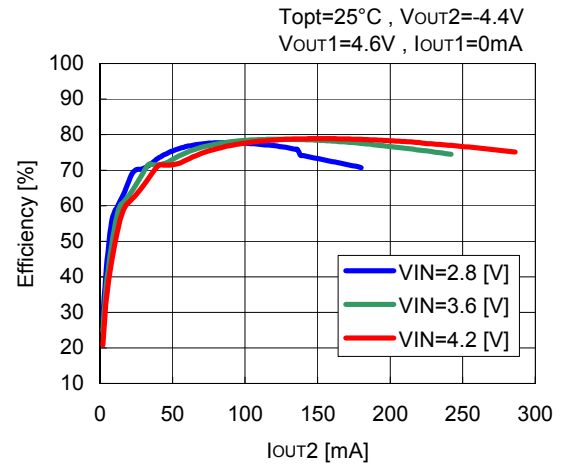

R1283x001C

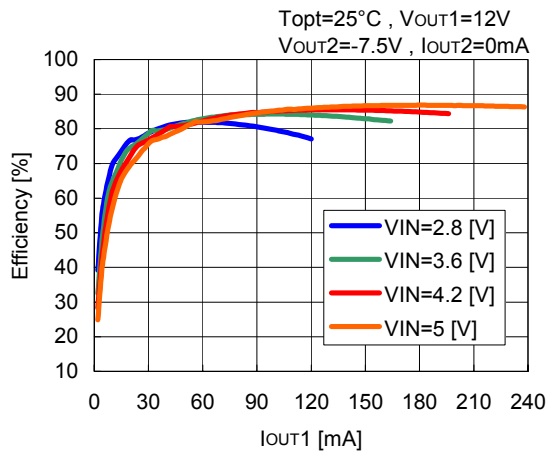

R1283x001C

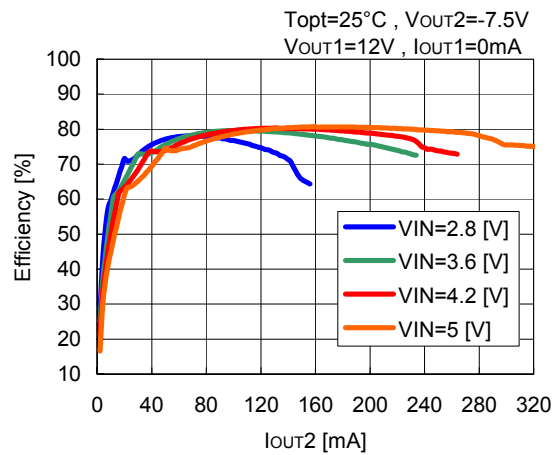

3) CE "L" Input Voltage vs. Temperature
R1283x00xx

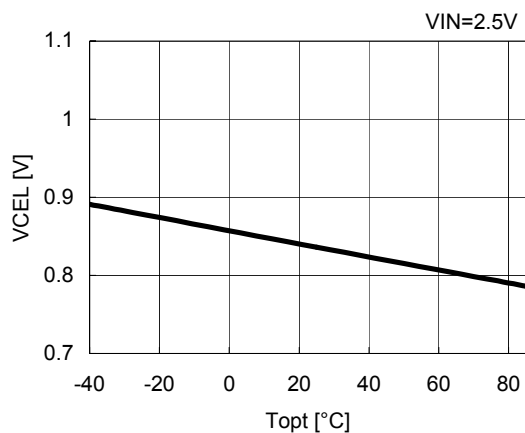

4) CE "H" Input Voltage vs. Temperature
R1283x00xx

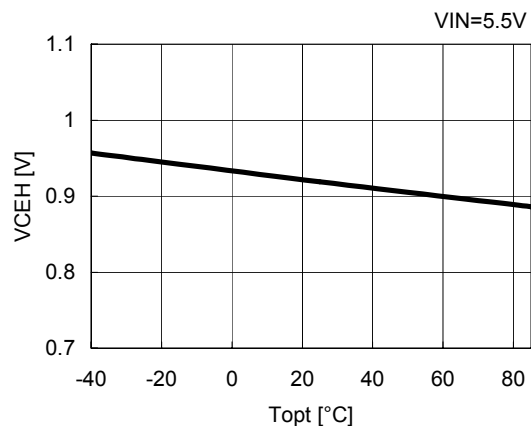

5) VFB1 Voltage vs. Temperature
R1283x00xx

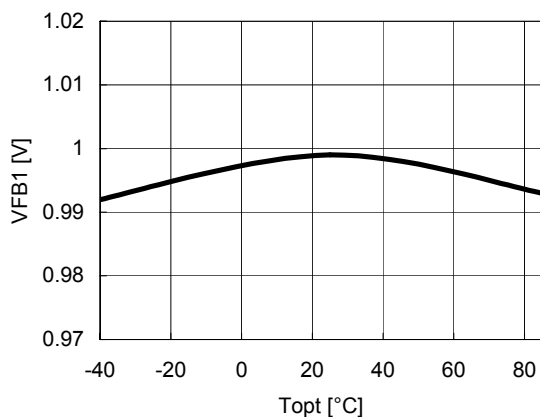

6) VFB2 Voltage vs. Temperature
R1283x00xx

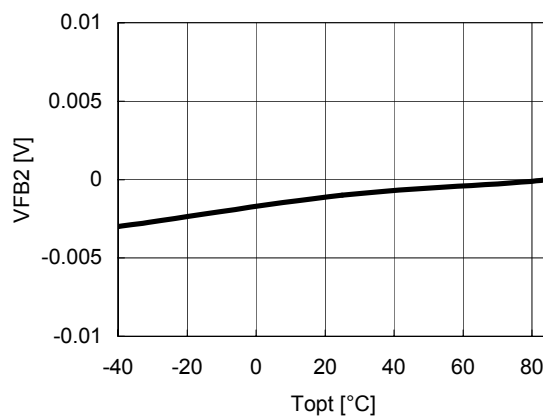

7) VREF Voltage vs. Temperature
R1283x00xx

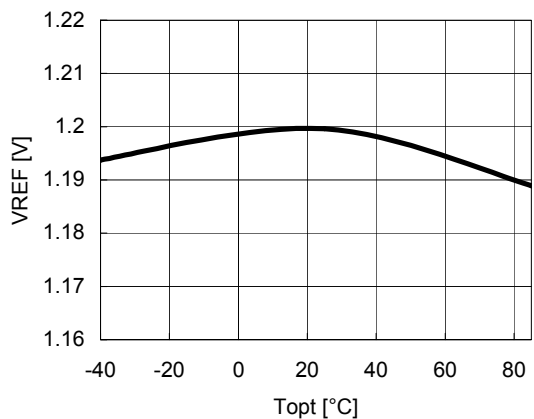

8) UVLO Voltage vs. Temperature
R1283x00xx

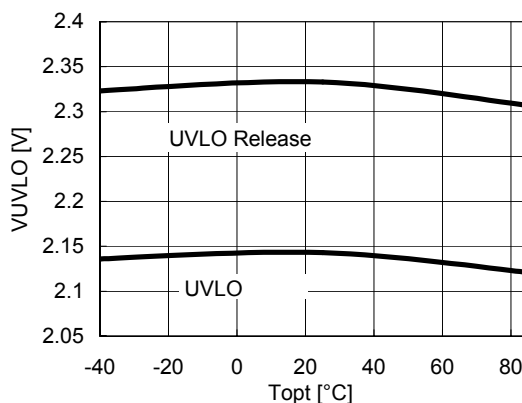

9) LX1 ON Resistance vs. Temperature
R1283x00xx

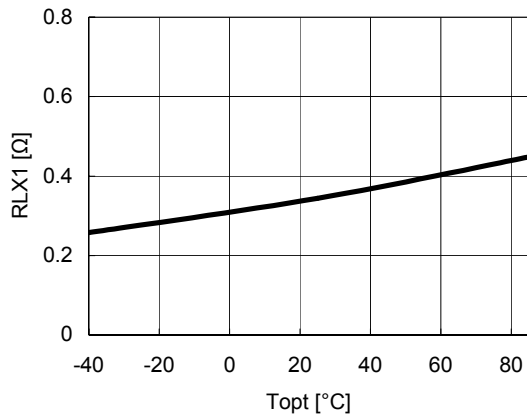

10) LX2 ON Resistance vs. Temperature
R1283x00xx

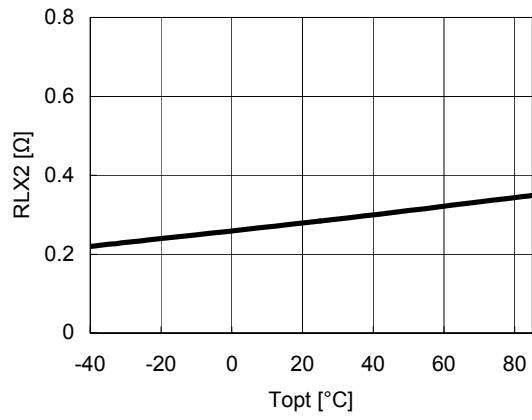

11) LX1 Limit Current vs. Temperature
R1283x00xx

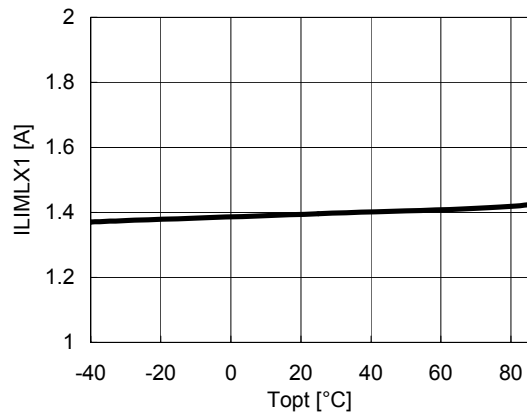

12) LX2 Limit Current vs. Temperature
R1283x00xx

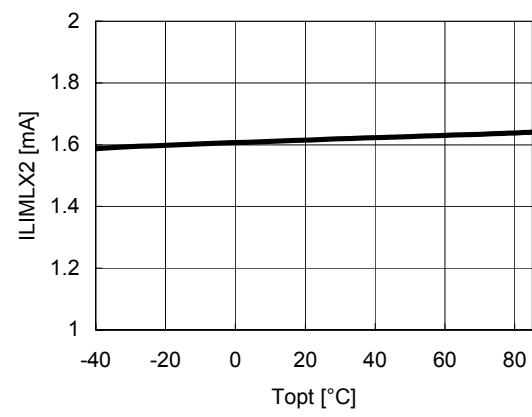

13) Osillator Frequency vs. Temperature
R1283x00xA

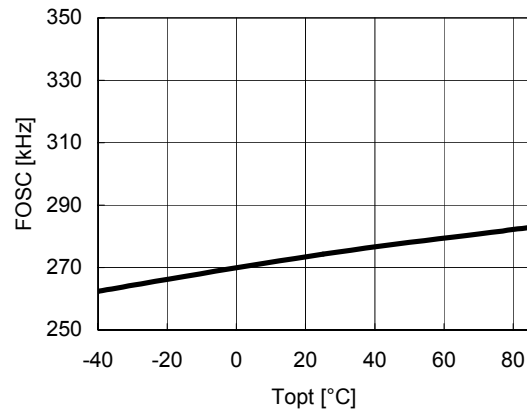

R1283x00xB

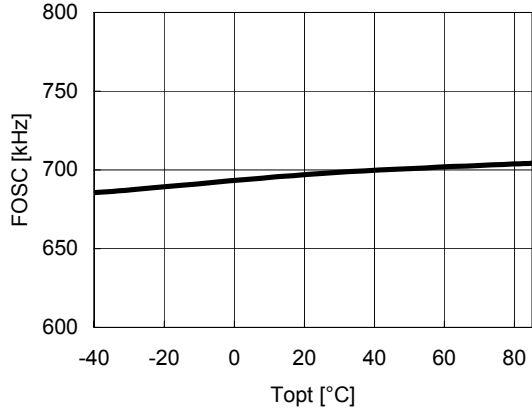

R1283x00xC

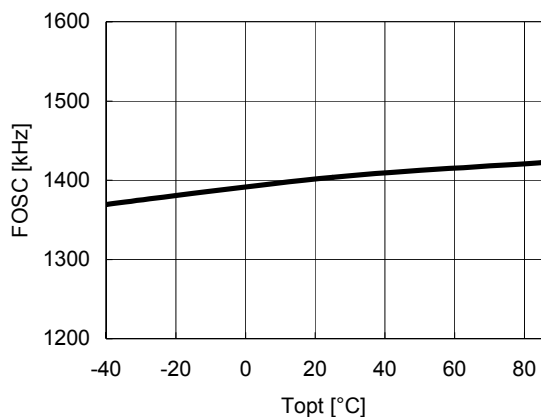

14) Maxduty1 vs. Temperature

R1283x00xA

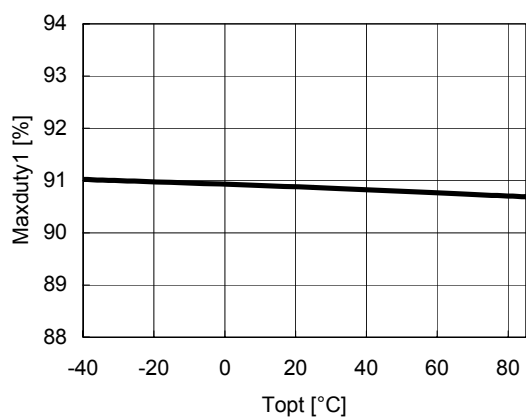

R1283x00xB

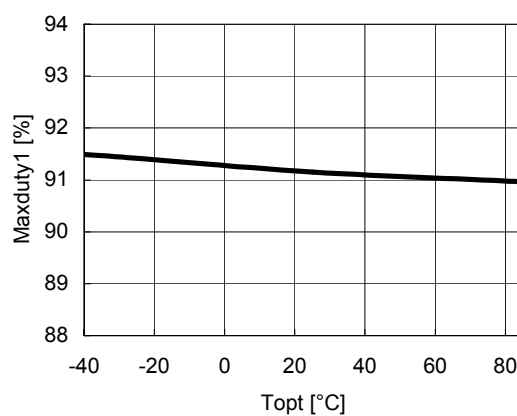

15) Maxduty2 vs. Temperature

R1283x00xC

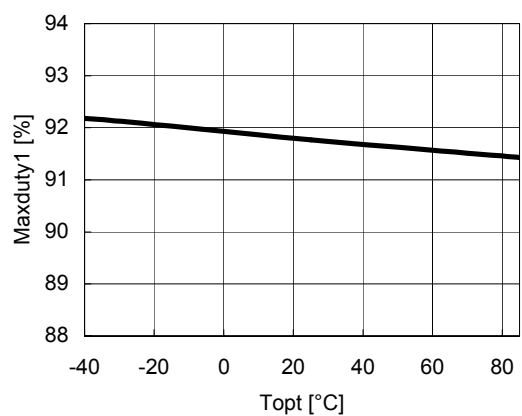

R1283x00xA

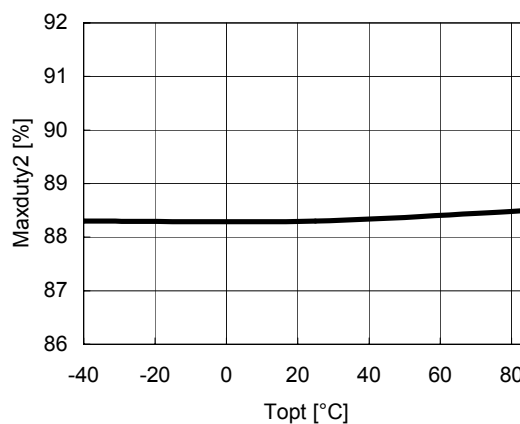

R1283x00xB

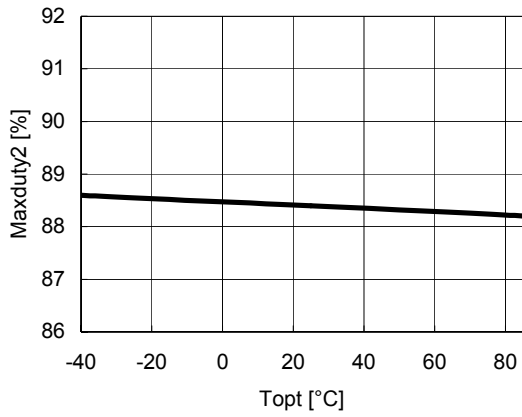

R1283x00xC

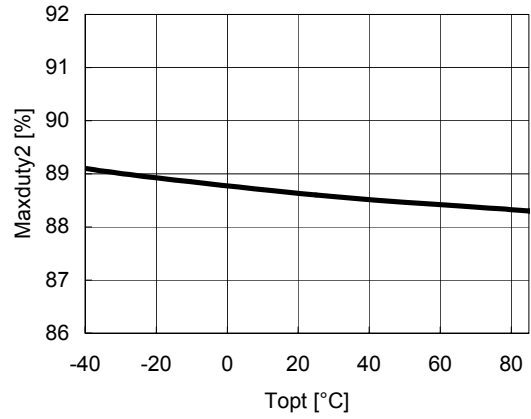

**16) CH1 Soft-start Time vs. Temperature
R1283x00xx**

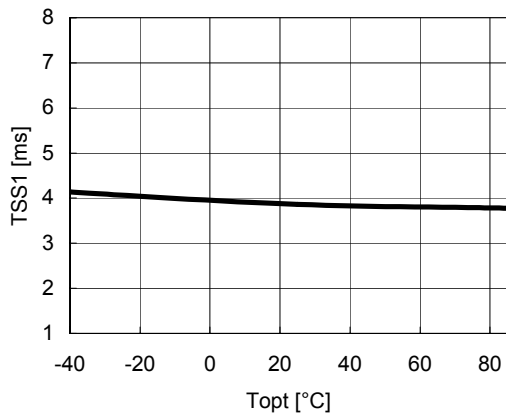

**17) CH2 Soft-start Time vs. Temperature
R1283x00xx**

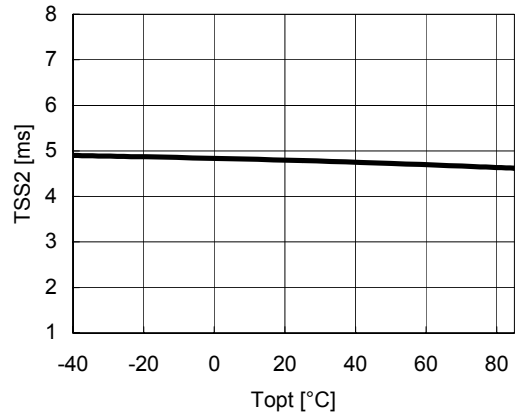

**18) Timer Latch Delay Time vs. Temperature
R1283x00xx**

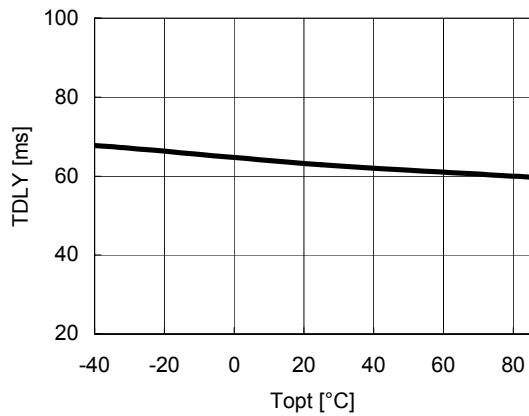

**19) VOUTN Discharge Current vs. Temperature
R1283x00xx**

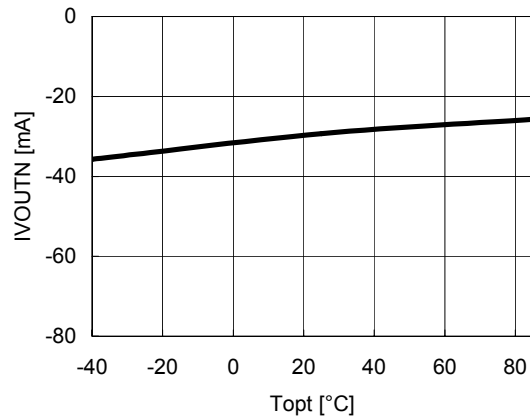

20) Startup Response

R1283x001x

$T_{opt}=25^{\circ}\text{C}$, $V_{IN}=3.6\text{V}$
 $V_{OUT1}=12\text{V}$, $V_{OUT2}=-7.5\text{V}$

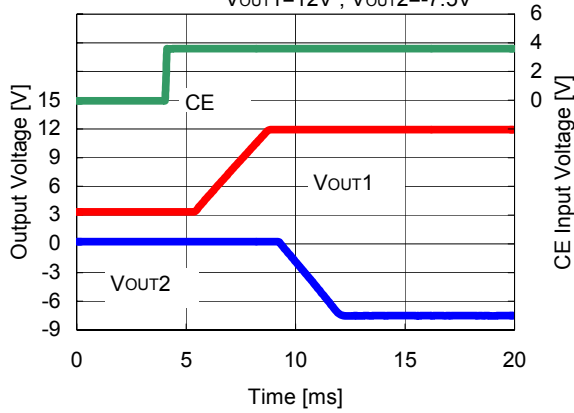

R1283x002x

$T_{opt}=25^{\circ}\text{C}$, $V_{IN}=3.6\text{V}$
 $V_{OUT1}=12\text{V}$, $V_{OUT2}=-7.5\text{V}$

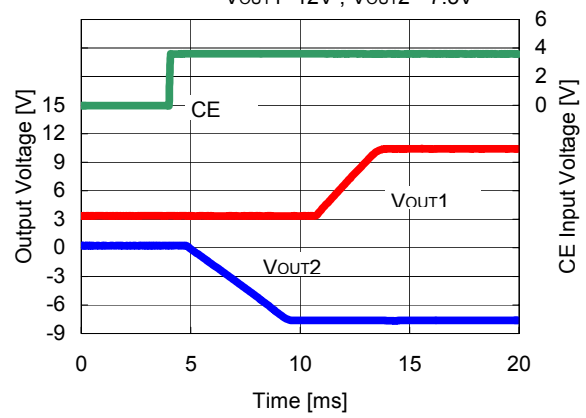

21) Shut down Response

R1283x001x

$T_{opt}=25^{\circ}\text{C}$, $V_{IN}=3.6\text{V}$
 $V_{OUT1}=12\text{V}$, $V_{OUT2}=-7.5\text{V}$
 $I_{OUT1}=10\text{mA}$

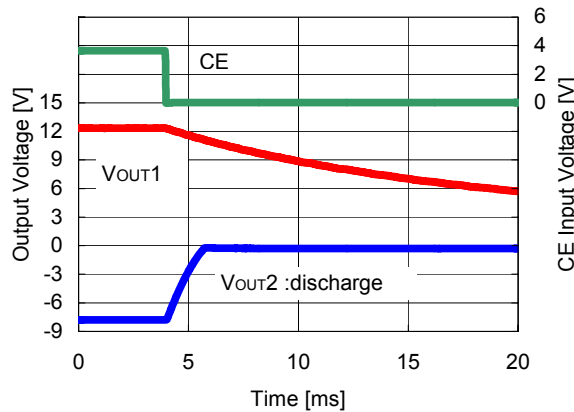

R1283x001x ($V_{OUTN}=\text{Open}$)

$T_{opt}=25^{\circ}\text{C}$, $V_{IN}=3.6\text{V}$
 $V_{OUT1}=12\text{V}$, $V_{OUT2}=-7.5\text{V}$
 $I_{OUT1}=10\text{mA}$

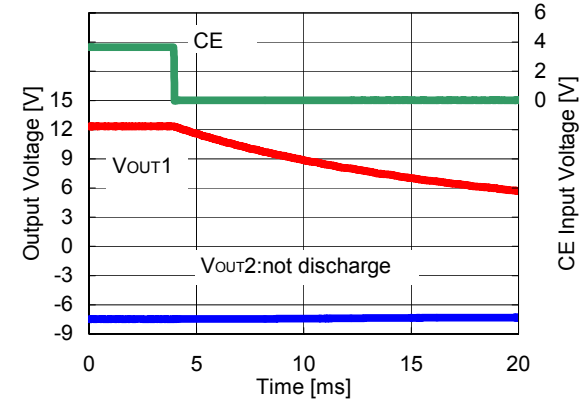

R1283x002x

$T_{opt}=25^{\circ}\text{C}$, $V_{IN}=3.6\text{V}$
 $V_{OUT1}=12\text{V}$, $V_{OUT2}=-7.5\text{V}$
 $I_{OUT1}=10\text{mA}$

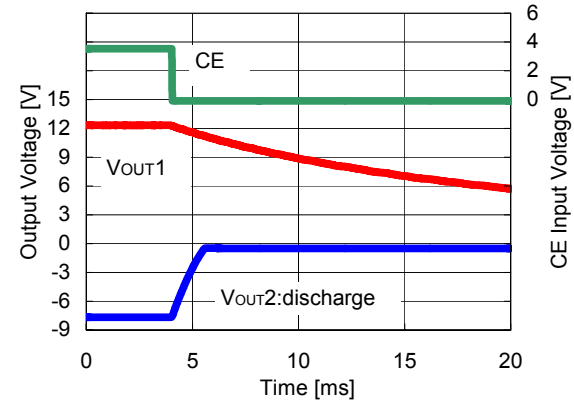

R1283x002x ($V_{OUTN}=\text{Open}$)

$T_{opt}=25^{\circ}\text{C}$, $V_{IN}=3.6\text{V}$
 $V_{OUT1}=12\text{V}$, $V_{OUT2}=-7.5\text{V}$
 $I_{OUT1}=10\text{mA}$

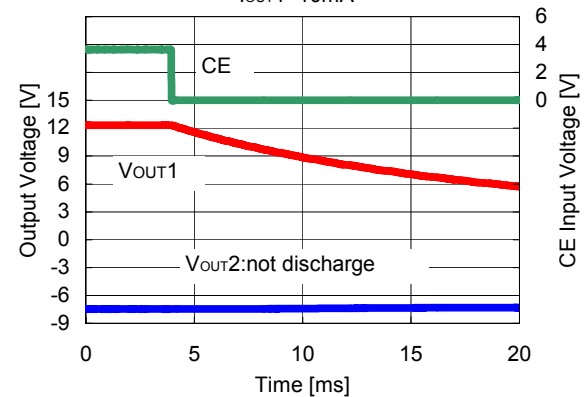

22) Load Transient Response

R1283x00xA

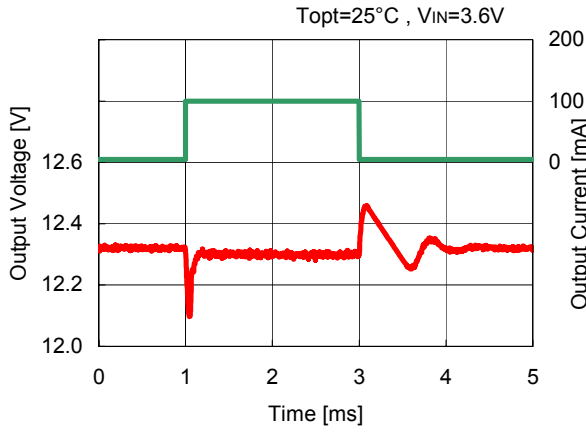

R1283x00xA

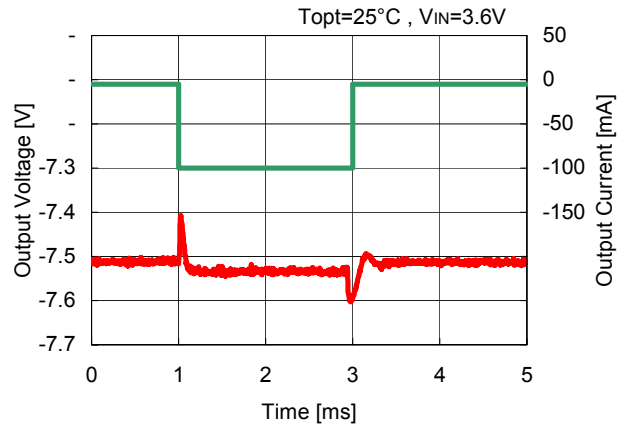

R1283x00xB

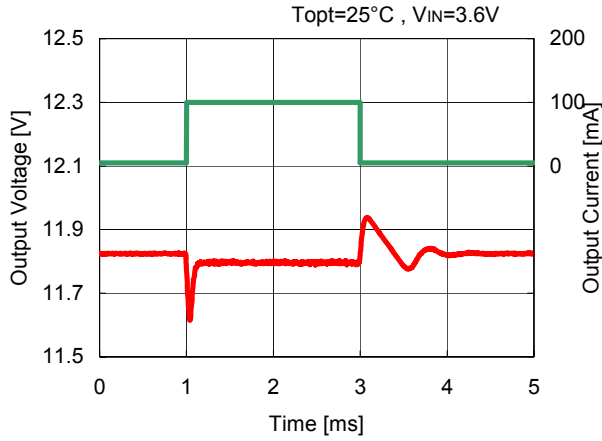

R1283x00xB

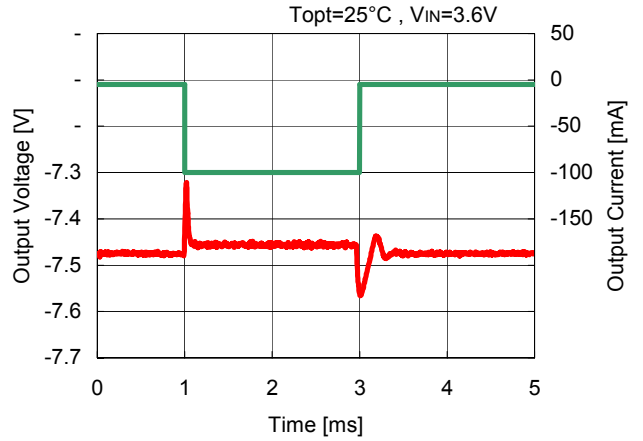

R1283x00xC

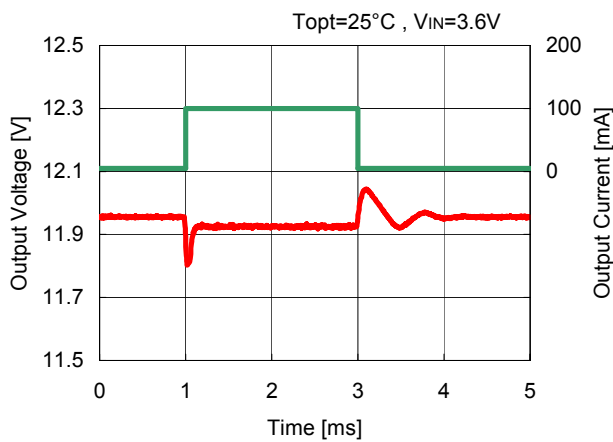

R1283x00xC

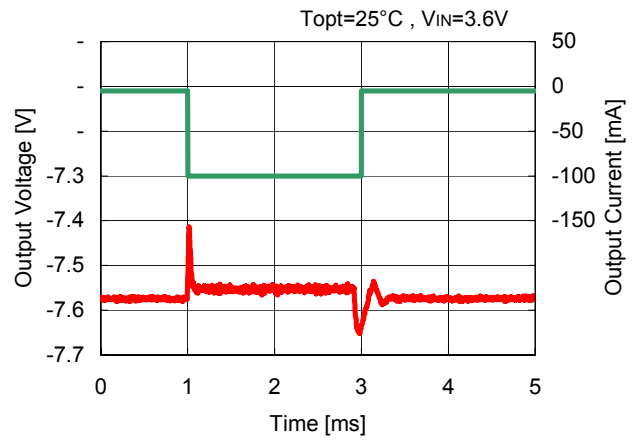

APPLIED CIRCUIT

1) Application with outputting power supply (+12V/-7.5V) for CCD from Li battery

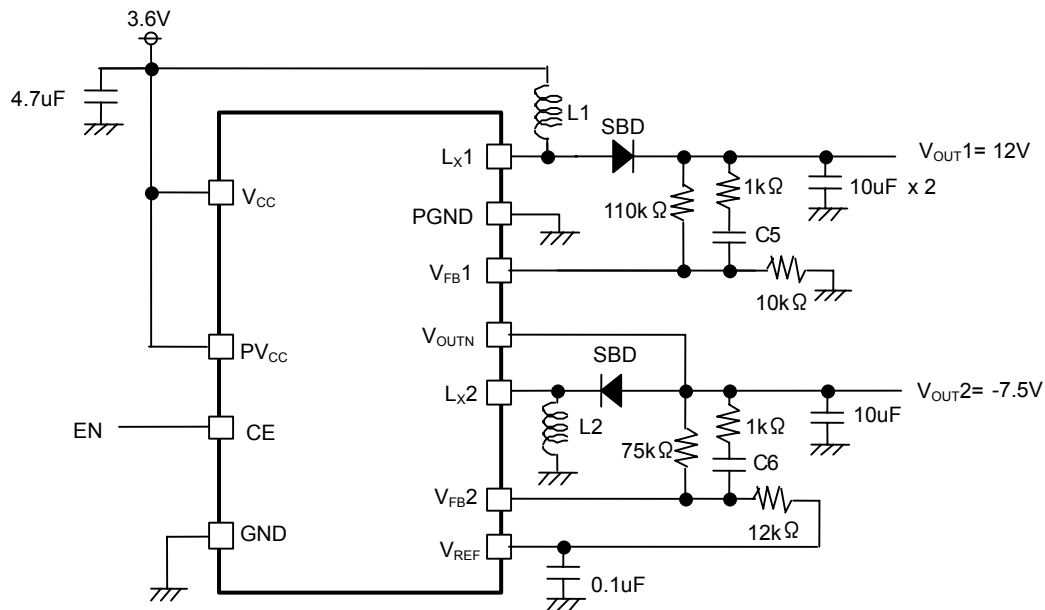

	L1	L2	C5	C6
R1283x00xA	15uH	10uH	220pF	220pF
R1283x00xB	6.8uH	6.8uH	150pF	150pF
R1283x00xC	4.7uH	4.7uH	220pF	220pF

Inductor	VLF3010(TDK)
SBD	CR02(TOSHIBA)

2) Application with outputting power supply (+4.6V/-4.4V) for AMOLED from Li battery

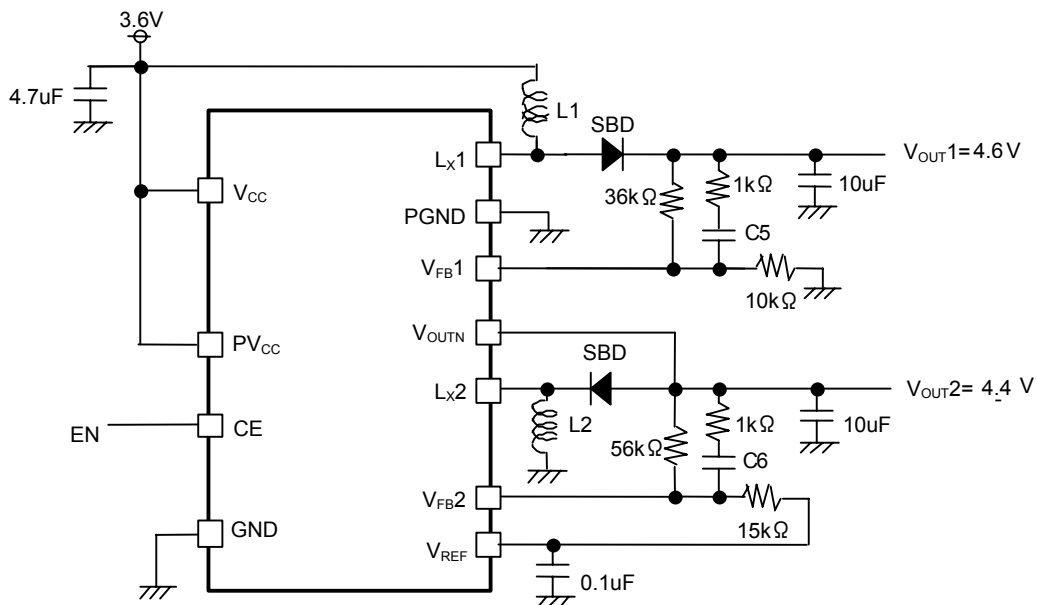

	L1	L2	C5	C6
R1283x00xA	15uH	10uH	100pF	100pF
R1283x00xB	4.7uH	4.7uH	47pF	33pF
R1283x00xC	4.7uH	4.7uH	68pF	47pF

Inductor	VLF3010(TDK)
SBD	CR02(TOSHIBA)

3) Application with output disconnect and discharge.

