

OUTLINE

The R5313B Series are complete power management system device for cellular phone, especially GSM handset application. The R5313B Series consists of nine voltage regulators, a large current regulator, Li-ion battery charger controller, several protection circuits, and SIM-I/F (can be used as two kinds voltage alternative regulator). The output voltages of all regulators are able to set different output voltage independently by laser trim as well as detector thresholds.

A tiny 48-pin CSP, 0.65mm ball pitch, is available.

FEATURES

- Low noise and good PSRR LDO regulators for RF and analog block.
- LDO with Power Save mode can be embedded.
- Standard LDO for Base Band I/O
- Vibrator VR
- RTC VR with very low quiescent current
- Backup VR with very low quiescent current (Charger for a coin cell, with reverse current protection)
- SIM power supply (2 kinds voltage alternative) and level shifter
- Power-on Reset
- Li-ion Battery Charger Controller with an LED driver
- Built-in Protection Circuits (Thermal Shutdown, Under Voltage Detector, Over-discharge Voltage Detector)
- Power on logic circuits
- Buzzer driver can be embedded.
- CMOS process.
- Package48pin CSP (5mm*5mm*1.05mm)

APPLICATIONS

- Cellular phones, such as GSM and W-CDMA handsets.
- Power supply for battery-powered appliances.

Mask Options: Customized settings are possible to choose options for each item.

Item	Contents
Charger Controller	Pulse Charge or CC/CV Charge
Regulator 1	(1) LDO with REG1PS="L" (2) Choose Output current ability 50mA / 100mA with PS="H" (3) Setting Voltage Range (2 kinds, one is powerful mode voltage, the other is power-save mode voltage): from 1.2V to 2.5V.
Regulator 2	(1) With ECO mode or Without ECO mode (If with ECO mode option is selected, each voltage setting is individual, CC/CV Charge controller and Buzzer driver cannot be selected.) (2) Choose Output current ability 100mA / 200mA with PS="H" (3) Setting Voltage Range: from 1.5V to 3.3V
Regulator 3	(1) Choose Output current ability 50mA / 100mA with PS="H" (2) Setting Voltage Range: from 1.5V to 3.3V
Regulator 4	Setting Voltage Range: from 2.0V to 3.0V for backup battery charge
Regulator 5	Setting Voltage Range: from 1.2V to 2.0V for RTC
Regulator 6	(1) Choose Output current ability 100mA / 200mA with PS="H" (2) Setting Voltage Range: from 1.5V to 3.3V
Regulator 7	(1) With ECO mode or Without ECO mode (If with ECO mode option is selected, each voltage setting is individual, CC/CV Charge controller and Buzzer driver cannot be selected.) (2) Choose Output current ability 100mA / 200mA with PS="H" (3) Setting Voltage Range: from 1.5V to 3.3V
Regulator 8	Setting Voltage Range: from 1.2V to 3.3V for Vibrator
Regulator 9	(1) Choose Output current ability 10mA / 50mA (2) Setting Voltage Range (2 kinds for SIM card, alternative with a signal for SIMSV pin): from 1.2V to 3.0V.
RESET detector	Setting Voltage Range: from 1.2V to 2.3V for CPU Reset
NORMAL detector	Setting Voltage Range: from 2.9V to 3.4V as Main battery voltage supervisor
Over-discharge detector	Setting Voltage Range: from 2.35V to 2.65V as Main battery over-charge voltage supervisor
Over-voltage detector	Setting Voltage Range: from 4.2V to 5.2V as Main battery presence checker
Under-voltage detector	Setting Voltage Range: from 0.95V to 1.30V as Main battery presence checker
Others	(1) Input pin polarity, pull-up/pull-down may be selectable (2) Auto discharge function can be built-in for voltage regulator each. (3) Customization for power-on logic

PIN CONFIGURATION

CSP0505-48 (Pin name set on Top View is an example)

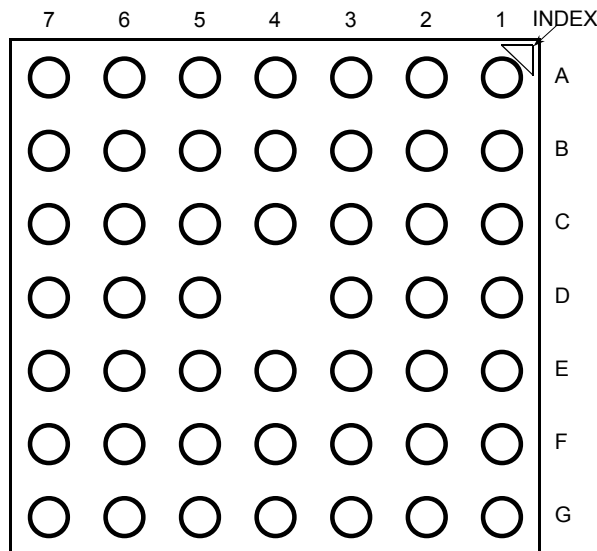

[BOTTOM VIEW]

A	VRF2	RFGND	VBAT4	BUZ-GND	VBAT3	BAT-RTC	GND2
B	VRF1	REG6EN	BUZ-OUT	AVCC	REG2EN	VPAD	VRTC
C	REG3EN	LED-OUT	CHG	REG7EN	BUZ-IN	UP-ON-OFF	TEST
D	DGND	CHG-IN	GATE-CHG		ON-OFF	DC-ON	VBAT5
E	VBAT1	SIM-IO	VSIM	RESET-IN	POWER-EN	REG8EN	V-VIB
F	SIM-RST	SIM-CLK	CLK-IN	SIM-SV	BATMON	RESETB	VCORE
G	DVCC	DATA-IO	SIM-EN	VTEST	REG1PS B	VBAT2	GND1
	1	2	3	4	5	6	7

[TOP VIEW]

PIN DESCRIPTIONS

• R5313BxxxG (example)

Pin No.	Bump No.	Symbol	Descriptions
1	D2	CHG-IN	Input Pin for Battery Charger
2	D1	DGND	Digital Ground Pin for Battery Charger, SIM Interface, and Vibrator.
3	E1	VBAT1	Input Pin for Main Battery.
4	C3	CHG	External Signal Input Pin for Battery Charger On/Off Mode
5	D3	GATE-CHG	Output Pin for PNP Tr. Control.
6	F5	BATMON	Battery Monitor Output Pin with 1% Accuracy
7	C1	REG3EN	External Signal Input Pin for REG3 On/Off Mode
8	C2	LED-OUT	Input Pin for LED
9	D6	DC-ON	Output Pin for AC/DC Adapter Detector. Output Type is CMOS.
10	D5	ON-OFF	Input Pin for Key On/Off
11	C6	UP-ON-OFF	Input Pin for Power-on signal keeper from Base Band LSI. CMOS Schmitt Input.
12	E5	POWER-EN	Output Pin for Base Band LSI "On" indicator.
13	B5	REG2EN	External Signal Input Pin for Reg2 On/Off Mode.
14	F6	RESETB	Detector Output Pin for Supervise Regulator 1 Output. Nch Open-Drain Output.
15	G6	VBAT2	Input Pin for Regulator 1.
16	F7	VCORE	Output Pin for Regulator 1.
17	G4	VTEST	Output Pin for Regulator 1 test.
18	G7	GND1	Ground Pin for Regulator 1
19	G5	REG1PSB	Powerful Mode/ Power-save Mode Alternative Control Input Pin for Regulator 1.
20	A5	VBAT3	Power Supply Pin for Regulator 2,3,and 4.
21	B4	AVCC	Output Pin for Regulator 2
22	A7	GND2	Ground Pin for Regulator 2
23	B6	VPAD	Output Pin for Regulator 3
24	A6	BAT-RTC	Output Pin for Regulator 4
25	B7	VRTC	Output Pin for Regulator 5
26	B2	REG6EN	External Signal Input Pin for Regulator 6 On/Off Mode
27	A3	VBAT4	Input Pin of Power Supply for Regulator 6 and 7.
28	C4	REG7EN	External Signal Input Pin for Regulator 7 On/Off Mode
29	B1	VRF1	Output Pin for Regulator 6
30	A2	RFGND	Ground pin for Regulator 6 and 7
31	A1	VRF2	Output Pin for Regulator 7
32	G1	DVCC	Power Supply Pin for SIM I/F
33	B3	BUZ-OUT	Output Pin for Buzzer Driver. Nch Open Drain Output Type.
34	A4	BUZ-GND	Ground Pin for Buzzer Driver.
35	C5	BUZ-IN	Gate Pin for Nch Tr.
36	D7	VBAT5	Input Pin for Regulator 8
37	E6	REG8EN	External Signal Input Pin for Regulator 8 On/Off Mode

R5313B

38	E7	V-VIB	Output Pin for Regulator 8
39	G3	SIM-EN	Input Pin for Power-on of SIM
40	F4	SIM-SV	Input Pin for selection of SIM Card Power Level (Alternative)
41	E4	RESET-IN	Reset Input Pin from Base Band LSI
42	F3	CLK-IN	Clock Input Pin from Base Band LSI
43	G2	DATA-IO	Data Input /Output Pin from Base Band LSI
44	E3	VSIM	Power Supply Pin for SIM
45	F1	SIM-RST	Output Pin for SIM Reset
46	F2	SIM-CLK	Output Pin for SIM Clock
47	E2	SIM-IO	Output pin for SIM Data
48	C7	TEST	Test Pin. (Connect to the Ground level.)

ABSOLUTE MAXIMUM RATINGS

Symbol	Item	Condetions	Rating	Unit
V _{BAT}	Power Supply Voltage	Battery Voltage Input Pins	-0.3 to 6.5	V
V _{CHG}	Cherger Terminal Input Voltage	CHG-IN Pin	-0.3 to 6.5 ^{*Note1}	V
			-0.3 to 8.0 ^{*Note2}	
V _{IN}	Input Voltage Range	All Input Pins	-0.3 to 6.5	V
I _{OUT}	Output Current	Regulator Output Pins (Except Reg 3/4/5/8)	I _{OUT} (Min.)×2	mA
		VPAD(REG3)	150	
		V-VIB(Reg8)	160	
		BUZOUT	150	
		LED-OUT	10	
P _D	Power Dissipation	Mounted on Board, T _{opt} =85°C; See Below	800	mW
T _{stg}	Storage Temperature		-55 to +125	°C

*Note 1: Bias Input

*Note 2: Pulse Input (1s) 30000 Times

Power Dissipation on CSP0505-48

Conditions: Board Size 50mm×108mm×1.27mm, Material: FR4, Wiring Density 250%/ Four Layers, T_j=125°C

Wind Velocity: 0m/s, θ_{ja}=50°C/W

Recommended Operating Conditions

Symbol	Item	Conditions	Min.	Typ.	Max.	Unit
V _{BAT}	Power Supply Operating Voltage	Battery Voltage Input Pins	1.0 ^{*Note3}	3.6	4.3	V
V _{CHG}	Charger Terminal Input Voltage	CHG-IN Pin	4.8	5.5	6.0	V
T _{opt}	Operating Temperature Range	for Charger Block	0		+50	°C
		for Others	-40		+85	°C

Note4: This value means the minimum operating voltage of Voltage Detectors.

ELECTRICAL CHARACTERISTICS

In all of the following electrical characteristics tables, unless otherwise provided, V_{BAT}=3.6V.

R5313B

LDO with Power Save Regulator

In the R5313, an LDO can be embedded as Regulator 1 with power-save mode.

There is a protection circuit which is the current limit circuit.

Normal Operating Mode (REG1PSB="H")<-Logic can be changed with Mask Option.

(T_{opt}=25°C)

Symbol	Item	Conditions	Min.	Typ.	Max.	Unit
V _{OUT}	Output Voltage	I _{OUT} =30mA	-2.0%		+2.0%	V
I _{SS}	Supply Current	I _{OUT} =0mA		90		μA
I _{LIM}	Short Current Limit			70		mA
I _{OUT}	Output Current		300			mA
V _{DIF}	Dropout Voltage	I _{OUT} =150mA		200		mV
ΔV _{OUT} /ΔI _{OUT}	Load Regulation	10μA ≤ I _{OUT} ≤ 300mA		15	40	mV
ΔV _{OUT} /ΔV _{IN}	Line Regulation	3.2V ≤ V _{BAT} ≤ 4.2V, I _{OUT} =30mA			0.2	%/V
RR	Ripple Rejection	V _{BAT} =3.6V+0.2Vp-p, I _{OUT} =30mA, f=1kHz		70		dB
ΔV _{OUT} /ΔT _{opt}	Output Voltage Temperature Coefficient	-40°C ≤ T _{opt} ≤ 85°C		±100		ppm/°C

Output Capacitor 4.7μF or more, Ceramic Type

R5313B

Power Save Mode (REG1PSB="L")<-Logic can be changed with Mask Option.

(Topt=25°C)

Symbol	Item	Conditions	Min.	Typ.	Max.	Unit
V _{OUT}	Output Voltage	I _{OUT} =10mA	-2.0%		+2.0%	V
I _{OUT}	Output Current		200			mA
V _{DIF}	Dropout Voltage	I _{OUT} =50mA		0.1		V
I _{SS}	Supply Current	I _{OUT} =0mA		12		μA
ΔV _{OUT} /ΔI _{OUT}	Load Regulation	10mA ≤ I _{OUT} ≤ 50mA		15	40	mV
ΔV _{OUT} /ΔV _{IN}	Line Regulation	3.2V ≤ V _{DD} ≤ 4.2V, I _{OUT} =25mA			0.2	%/V
ΔV _{OUT} /ΔTopt	Output Voltage Temperature Coefficient	-40°C ≤ Topt ≤ 85°C		±100		ppm/°C

*Low Noise LDO

3ch-low noise LDO (Regulator 2,6,7) with short current limit circuit and On/Off switch can be built in the R5313. (As for Regulator 2 and Regulator 7, ECO mode can be set by Mask Option.)

High Speed Mode

(Topt=25°C)

Symbol	Item	Conditions	Min.	Typ.	Max.	Unit
V _{OUT}	Output Voltage	I _{OUT} =30mA	-2.0%		+2.0%	V
I _{OUT}	Output Current ^{*Note8}		100			mA
V _{DIF}	Dropout Voltage	I _{OUT} =100mA		0.15	0.25	V
I _{LIM}	Short Current Limit	V _{OUT} =0V		40		mA
ΔV _{OUT} /ΔI _{OUT}	Load Regulation	10μA ≤ I _{OUT} ≤ 100mA			40	mV
I _{SS}	Supply Current ^{*Note9}	I _{OUT} =0mA		90		μA
RR	Ripple Rejection	V _{BAT} =3.6V+ 0.2Vpp, f=1kHz, I _{OUT} =30mA		70		dB
ΔV _{OUT} /ΔV _{IN}	Line Regulation	I _{OUT} =30mA 3.2V ≤ V _{DD} ≤ 4.2V			0.2	%/V
ΔV _{OUT} /ΔTopt	Output Voltage Temperature Coefficient	-40°C ≤ Topt ≤ 85°C		±100		ppm/°C
En	Output Noise	I _{OUT} =50mA BW=10Hz to 100kHz		30		μVrms
Vtd	Turn-on Speed	I _{OUT} =50mA, V _{OUT} ×90% C _L =1μF		20		μs

*Note8: Output Current Min. can be changed up to 200mA with Mask Option.

*Note9: Supply Current can be reduced into 3μA if ECO mode is set with Mask Option.

Output Capacitor: Ceramic 1μF

Recommendation: GRM219R61A105K (Murata)

General examples: C1608X5R0J105K (TDK), GRM188R60J105K (Murata)

Voltage Regulator 3/ For I/O Supply

(T_{opt}=25°C)

Symbol	Item	Conditions	Min.	Typ.	Max.	Unit
V _{OUT}	Output Voltage	I _{OUT} =10mA	-2.0%		+2.0%	V
I _{OUT}	Output Current		100			mA
V _{DIF}	Dropout Voltage	I _{OUT} =100mA		280		mV
I _{SS}	Supply Current	I _{OUT} =0mA		3		μA
I _{LIM}	Short Current Limit	V _{OUT} =0V		50		mA
ΔV _{OUT} /ΔI _{OUT}	Load Regulation	10μA ≤ I _{OUT} ≤ 100mA			80	mV
ΔV _{OUT} /ΔV _{IN}	Line Regulation	I _{OUT} =25mA, 3.2V ≤ V _{BAT} ≤ 4.2V			0.2	%/V
ΔV _{OUT} /ΔT _{opt}	Output Voltage Temperature Coefficient	-40°C ≤ T _{opt} ≤ 85°C		±100		ppm/°C

Output Capacitor: Ceramic 1μF

Voltage Regulator4/ For Backup Battery with a reverse current protection

(T_{opt}=25°C)

Symbol	Item	Conditions	Min.	Typ.	Max.	Unit
V _{OUT}	Output Voltage	I _{OUT} =0.5mA	-2.0%		+2.0%	V
I _{OUTMAX}	Maximum Output Current	V _{OUT} =2.25V	0.4	1.0	2.0	mA
V _{DIF}	Dropout Voltage	I _{OUT} =0.5mA		30		mV
I _{SS}	Supply Current	I _{OUT} =0mA		2		μA
I _{REV}	Output Reverse Current	V _{BAT} =0V, BAT_RTC=3.0V		1		μA
ΔV _{OUT} /ΔI _{OUT}	Load Regulation	10μA ≤ I _{OUT} ≤ 0.5mA			50	mV
ΔV _{OUT} /ΔV _{IN}	Line Regulation	I _{OUT} =0.5mA, 3.2V ≤ V _{BAT} ≤ 4.2V			0.2	%/V
ΔV _{OUT5} /ΔT _{opt}	Output Voltage Temperature Coefficient	-40°C ≤ T _{opt} ≤ 85°C		±100		ppm/°C

Output Capacitor: Ceramic 0.1μF

Voltage Regulator5/ For RTC

(T_{opt}=25°C)

Symbol	Item	Conditions	Min.	Typ.	Max.	Unit
V _{OUT}	Output Voltage	I _{OUT} =0.1mA	-2.0%		+2.0%	V
I _{OUTMAX}	Maximum Output Current	V _{OUT} =1.3V	0.3	1.0	2.0	mA
V _{DIF}	Dropout Voltage	I _{OUT} =0.25mA		30		mV
I _{SS}	Supply Current	I _{OUT} =0mA		1		μA
ΔV _{OUT} /ΔI _{OUT}	Load Regulation	10μA ≤ I _{OUT} ≤ 0.25mA			50	mV
ΔV _{OUT} /ΔV _{IN}	Line Regulation	I _{OUT} =0.25mA, 3.2V ≤ V _{BAT} ≤ 4.2V			0.2	%/V
ΔV _{OUT} /ΔT _{opt}	Output Voltage Temperature Coefficient	-40°C ≤ T _{opt} ≤ 85°C		±100		ppm/°C

Output Capacitor: Ceramic 0.1μF

R5313B

Voltage Regulator8/ VR8: For Vibrator

(T_{opt}=25°C)

Symbol	Item	Conditions	Min.	Typ.	Max.	Unit
V _{OUT}	Output Voltage	I _{OUT} =10mA	-2.0%		+2.0%	V
I _{OUT}	Output Current		150			mA
V _{DIF}	Dropout Voltage	I _{OUT} =150mA		400	600	mV
I _{SS}	Supply Current	I _{OUT} =0mA		3		μA
I _{LIM}	Current Limit	V _{OUT} =0V		50		mA
ΔV _{OUT} /ΔI _{OUT}	Load Regulation	10μA ≤ I _{OUT} ≤ 150mA			120	mV
ΔV _{OUT} /ΔV _{IN}	Line Regulation	3.2V ≤ V _{BAT} ≤ 4.2V, I _{OUT} =30mA			0.2	%/V
ΔV _{OUT} /ΔT _{opt}	Output Voltage Temperature Coefficient	-40°C ≤ T _{opt} ≤ 85°C		±100		ppm/°C

Output Capacitor: Ceramic 1.0μF

Power ON Block Specification

Normal Operating Battery Voltage Detector/

(T_{opt}=25°C)

Symbol	Item	Conditions	Min.	Typ.	Max.	Unit
+V _{DET}	Released Voltage	V _{BAT} V _{BAT} T-NORMAL="L" to "H"	Typ. -50mV		Typ. +50mV	V
I _{SS}	Supply Current	V _{BAT} =4.2V		2		μA

DC-ON Comparator

(T_{opt}=25°C)

Symbol	Item	Conditions	Min.	Typ.	Max.	Unit
V _{OFFSET}	Offset Voltage	CHG-IN-V _{BAT}	3	30	60	mV
I _{SS}	Supply Current	CHG-IN=5.0V		2		μA
T _{DOUT}	Output Delay Time	DC-ON="H" to "L"		150		μs

Thermal Shutdown Circuit

Thermal shutdown circuit consists of two temperature detectors and an Op-amp.

V_{BAT}=3.6V

Symbol	Item	Conditions	Min.	Typ.	Max.	Unit
T _{DET}	Detect Temperature	CHG-IN-V _{BAT}		140		°C
T _{HYS}	Temperature Hysteresis Range	CHG-IN=5.0V		25		°C
I _{SS}	Supply Current	DC-ON="H" to "L"		2		μA

Charger Block
Battery Charge Control Unit*Note11

(T_{opt}=25°C)

Symbol	Item	Conditions	Min.	Typ.	Max.	Unit
I _{PRE}	Pre-charge Current	CHG-IN=5.5V, V _{BAT} =3.0V	40	50	60	mA
I _{CHG}	Base Current	CHG-IN=5.5V, GATE-CHG=4.5V	30	40	50	mA
I _{SS}	Supply Current	CHG-IN=5.5V		950		μA

*Note11: Charging method can be changed into CC/CV type with Mask Option

Battery Monitor

(T_{opt}=25°C)

Symbol	Item	Conditions	Min.	Typ.	Max.	Unit
V _{MON}	Battery Monitor Accuracy		-1.0%		+1.0%	V
R _{MON}	Battery Monitor Total Resistance Value		1	2	4	MΩ

Flash LED

(T_{opt}=25°C)

Symbol	Item	Conditions	Min.	Typ.	Max.	Unit
T _{ON}	ON time	V _{BAT} =3.0V		80		ms
T _P	Time Period		0.7	1.0	1.3	s
V _{OL}	"L" Output Voltage	I _{OUT} =5mA, V _{BAT} =3.0V			0.4	V

Battery Presence Detector
Over Voltage

(T_{opt}=25°C)

Symbol	Item	Conditions	Min.	Typ.	Max.	Unit
+V _{DET}	Released Voltage	V _{BAT} BAT-PRES="H" to "L"	Typ. -80mV		Typ. +80mV	V
I _{SS}	Supply Current	V _{BAT} =4.2V		1		μA

Under Voltage

(T_{opt}=25°C)

Symbol	Item	Conditions	Min.	Typ.	Max.	Unit
-V _{DET}	Detector Threshold Voltage	V _{BAT} BAT-PRES="H" to "L"	Typ. -0.1V		Typ. +0.1V	V
V _{HYS}	Hysteresis Range			3		%
I _{SS}	Supply Current	V _{BAT} =4.2V		1		μA

Block Diagram

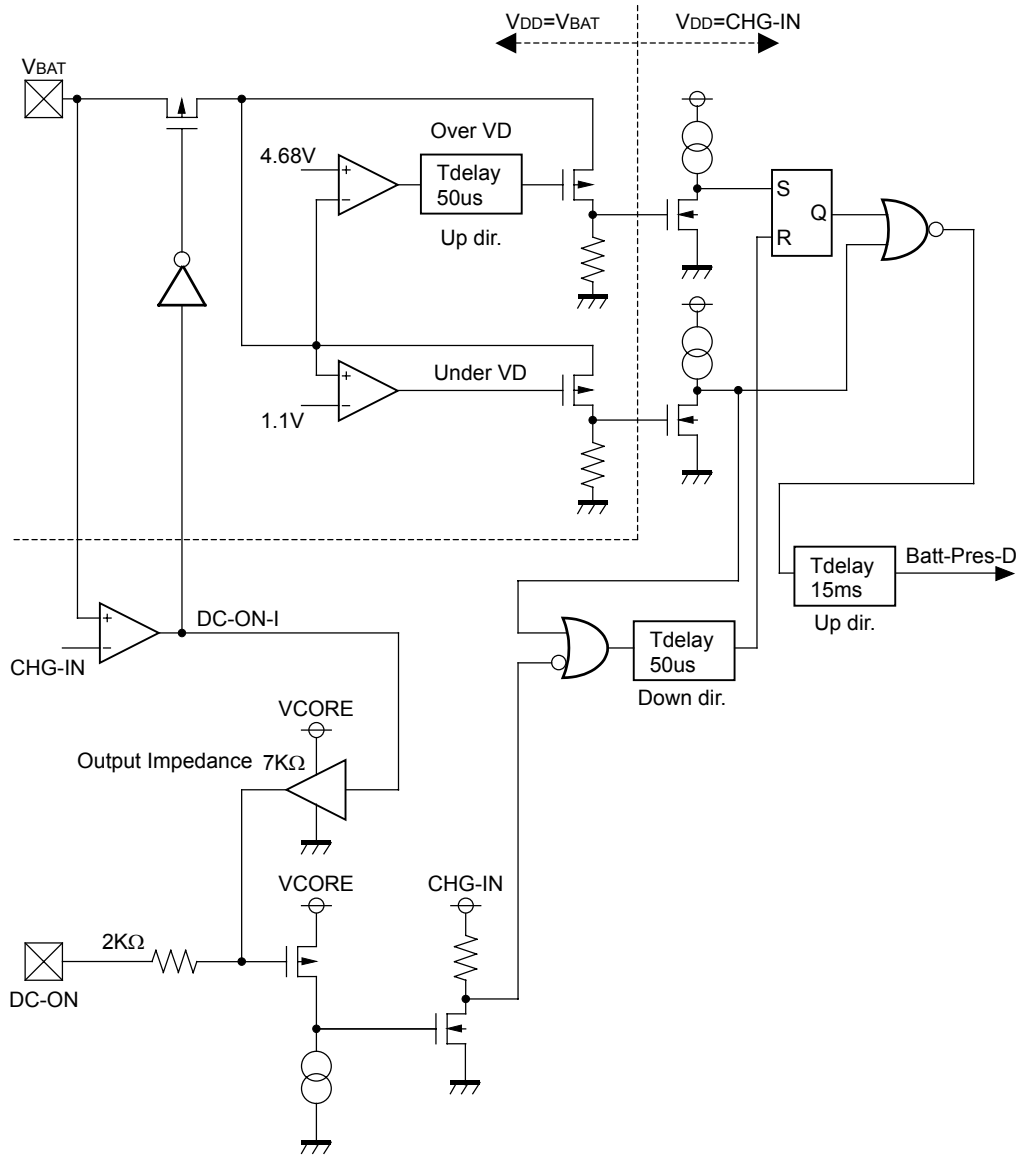

SIM Block

Block Diagram

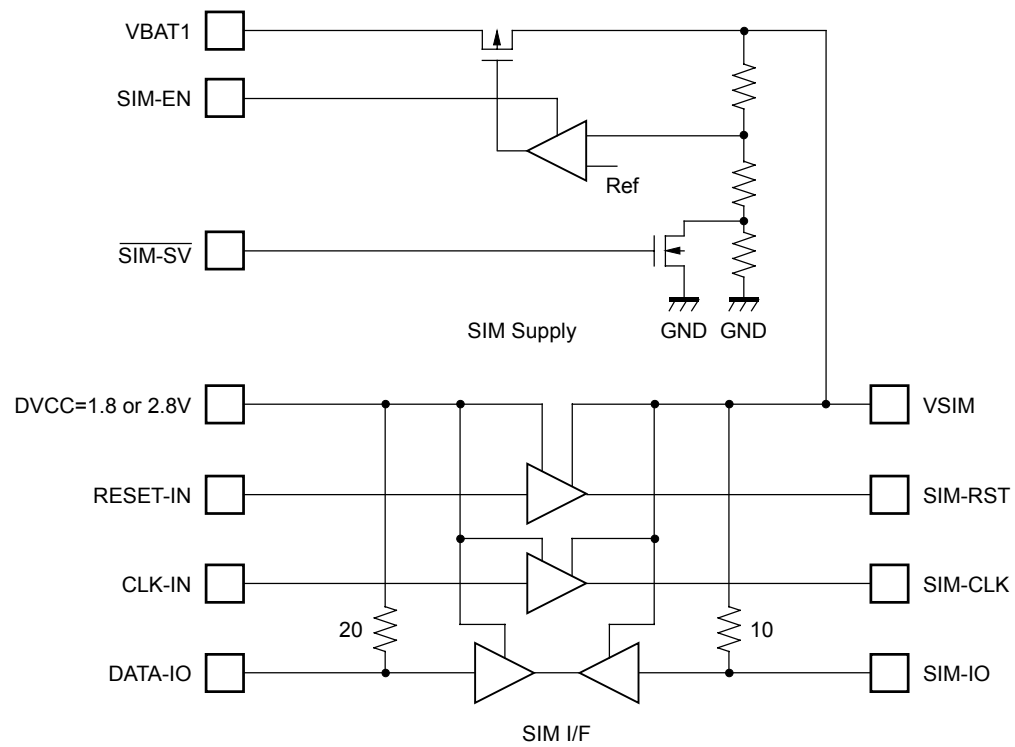

R5313B

SIM Supply

The SIM supply circuit consists of a reference voltage source, an error amplifier, a driver transistor, resistor net for output voltage setting, and a current limit circuit.

(Topt=25°C)

Symbol	Item	Conditions	Min.	Typ.	Max.	Unit
V _{OUT}	Output Voltage	I _{OUT} =1mA, SIMSV="L"	-2.0%		+2.0%	V
		I _{OUT} =1mA, SIMSV="H"	-3.0% *Note13		+3.0%	
I _{OUT}	Output Current *Note12		10			mA
V _{DIF}	Dropout Voltage	I _{OUT} =10mA, SIMSV="L" *Note14		35	100	mV
		I _{OUT} =10mA, SIMSV="H" *Note15		55	150	
ΔV _{OUT} /ΔI _{OUT}	Load Regulation	10μA ≤ I _{OUT} ≤ 10mA			20	mV
I _{SS}	Supply Current	I _{OUT} =0mA		3		μA
I _{LIM}	Short Current Limit	V _{SIM} =0V		2		mA
ΔV _{OUT} /ΔV _{IN}	Line Regulation	I _{OUT} =5mA, 3.2V ≤ V _{BAT} ≤ 4.2V			0.2	%/V
ΔV _{OUT} /ΔT	Output Voltage Temperature Coefficient	-40°C ≤ Topt ≤ 85°C		±100		ppm/°C

*Note12: Output Current Min. can be changed up to 50mA with Mask Option.

*Note13: 2% Tolerance is acceptable by Mask Option, or voltage setting. Output Capacitor: Ceramic 0.1μF

*Note14: Dropout voltage depends on the output voltage setting, this value is based on the case that V_{OUT}=2.8V.

*Note15: Dropout voltage depends on the output voltage setting, this value is based on the case that V_{OUT}=1.8V.

SIM I/F Block

Digital I/F (RESET-IN, CLK-IN, DATA-IO)

(Topt=25°C)

Symbol	Item	Conditions	Min.	Typ.	Max.	Unit
I _{DVCC}	DVCC Operating Current	CLK-IN=3.25MHz, DVCC=2.8V		8	15	μA
I _{IH} , I _{IL}	Input Current	CLK-IN, RST-IN	-0.1		0.1	μA
I _{IL}	Input Current	SIM-EN, SIM-SV	-0.1		0.1	μA
I _{IH}	"H" Input Current	DATA-IO	-20		20	μA
I _{IL}	"L" Input Current	DATA-IO			1	μA
V _{IH}	"H" Input Voltage	CLK-IN, RST-IN	DVCC×0.8			V
		DATA-IO *Note16	DVCC-0.6			
V _{IL}	"L" Input Voltage	CLK-IN, RST-IN			DVCC×0.2	V
		DATA-IO *Note17			0.3	
V _{OH}	"H" Output Voltage	DATA-IO, I _{OH} =-20μA, DVCC=2.8V	DVCC×0.7			V
V _{OL}	"L" Output Voltage	DATA-IO, I _{OL} =200mA			0.4	V
TRTF	Rising/Falling Time	DATA-IO Load=30pF		1.3		μs
R _{DATA}	Pull-up Resistance	Between DATA-IO and DVCC	12	20	32	kΩ

*Note16: V_{IH} is defined at which the output voltage exceeds the input voltage by 100mV.

*Note17: V_{IL} is defined at which the output voltage equals to 0.5V.

SIM Interface (SIM-RST, SIM-CLK, SIM-IO)

(T_{opt}=25°C)

Symbol	Item	Conditions	Min.	Typ.	Max.	Unit
I _{VSIM}	VSIM Operating Current	CLK-IN=3.25MHz, VSIM=2.8V		200	350	μA
V _{IH}	"H" Input Voltage	SIM-IO* ^{Note18}	VSIM×0.7			V
V _{IL}	"L" Input Voltage	SIM-IO* ^{Note19}			0.3	V
V _{OH}	"H" Output Voltage	SIM-IO, I _{OH} =-20μA	VSIM×0.8			V
		SIM-RST, SIM-CLK, I _{OH} =-20mA	VSIM×0.9			V
V _{OL}	"L" Output Voltage	SIM-RST, SIM-CLK, I _{OL} =200mA			0.4	V
		SIM-IO, I _{OL} =1mA, DATA-IO<0.2V				
I _{IH}	"H" Input Current	SIM-IO	-20		20	μA
I _{IL}	"L" Input Current	SIM-IO			1	mA
VSD	Shutdown Output Voltage	SIM-RST, SIM-CLK, SIM-IO, VSIM (SIM-EN=GND, I _{OL} =200mA)			0.4	V
TRTF	Rising/Falling Time	SIM-IO, Load=30pF		0.7		μs
TRTF	Rising/Falling Time	SIM-RST, Load=30pF		20		ns
TRTF	Rising/Falling Time	SIM-CLK, Load=30pF		20		ns
FCLK	Input Frequency	SIM-CLK, Load=30pF			5	MHz
RSIM	Pull-up Resistance	Between SIM-IO and VSIM	6	10	16	kΩ

*Note18: V_{IH} is defined at which the output voltage exceeds the input voltage by 100mV.

*Note19: V_{IL} is defined at which the output voltage equals to 0.5V.

Others

Reset Generator

The reset generator consists of a voltage reference unit, a comparator, resistors for voltage detect, an output driver, and an output delay circuit. Output type is Nch open drain type.

(T_{opt}=25°C)

Symbol	Item	Conditions	Min.	Typ.	Max.	Unit
-V _{DET}	Detector Threshold	V _{CORE} RESETB="H" to "L"	-2.0%		+2.0%	V
I _{OUT}	Output Current	V _{DS} =0.5V, V _{CORE} =1.5V	1.5	4.0		mA
I _{SS}	Supply Current	V _{BAT} =4.2V		2.0		μA
T _{DELAY}	Release Voltage Output Delay Time		20	40	100	ms
T _{DOUT}	Detect Output Delay Time			40		μs

R5313B

Over-discharge Detector

Over-discharge detector consists of a voltage reference unit, a comparator, and resistors for voltage detection.

(T_{opt}=25°C)

Symbol	Item	Conditions	Min.	Typ.	Max.	Unit
-V _{DET}	Detector Threshold	V _{BAT} REG4EN="H" to "L"	-2.0%		+2.0%	V
V _{HYS}	Hysteresis Range			3.0		%
I _{SS}	Supply Current	V _{BAT} =4.2V		1.0		μA

Buzzer (can be eliminated with Mask Option.)

The buzzer circuit consists of N-channel transistor.

Connect the BUZ-IN pin directly to the gate of N-channel transistor.

(T_{opt}=25°C)

Symbol	Item	Conditions	Min.	Typ.	Max.	Unit
V _{OL}	"L" Output Voltage	I _{OL} =100mA, BUZ-IN=1.8V			0.4	V
I _{OFF}	Off Leakage Current	BUZ-IN<0.3V, BUZ-OUT=4.2V			1.0	μA

Power supply consumption table

(T_{opt}=25°C)

Symbol	Enabled Circuits	Typ.	Max.	Unit
V _{BAT} <2.4V	Over-discharge	2.0	3.2	μA
2.6V<V _{BAT} <4.6V, Power Off	Over-discharge, REG4(for backup), REG5(for RTC)	4.0	8.0	μA
3.15V<V _{BAT} <4.6V, Power On (Idle without RX or TX burst)	REG4(for backup), REG5(for RTC), REG1(PS mode), Reset Generator, REG3(for I/O), SIM Supply, Thermal Shutdown	24	42	μA
3.15V<V _{BAT} <4.6V, Power On(RX or TX burst)	REG4(for backup), REG5(for RTC), REG1(LDO mode), Reset Generator, REG2(for Analog), REG3(for I/O), SIM Supply, Thermal Shutdown, REG6/7(for RF)	400	600	μA

*Load conditions for all regulators: I_{OUT}=0mA

I/O Characteristics

Digital Unit

(T_{opt}=25°C)

Symbol	Item	Conditions	Min.	Typ.	Max.	Unit
I _{IL}	"L" Input Leakage Current	V _I =0V(Pull-down input terminals)	-0.1		0.1	μA
I _{IH}	"H" Input Leakage Current	UP-ON-OFF	-0.1		0.1	μA
V _{IH}	"H" Input Voltage	CHG, REG3EN, REG2EN, REG1PSB, REG6EN REG7EN, REG8EN, SIM-EN, SIM-SV, BUZ-IN	1.5		6.0	V
V _{IL}	"L" Input Voltage	CHG, REG3EN, REG2EN, REG1PSB, REG6EN REG7EN, REG8EN, SIM-EN, SIM-SV, BUZ-IN			0.3	V
V _{IH}	"H" Input Voltage	ON-OFF	V _{BAT} ×0.8		6.0	V
V _{IL}	"L" Input Voltage	ON-OFF			V _{BAT} ×0.2	V
V _{IH}	"H" Input Voltage	UP-ON-OFF	V _{VRTC} ×0.8		6.0	V
V _{IL}	"L" Input Voltage	UP-ON-OFF			0.25	V
V _{OH}	"H" Output Voltage	POWER-EN, I _{OH} =-100mA	V _{CORE} -0.2		6.0	V
V _{OL}	"L" Output Voltage	POWER-EN, I _{OL} =200mA			0.2	V
V _{IH}	"H" Input Voltage	DC-ON	V _{CORE} -0.2		V _{CORE}	V
V _{IL}	"L" Input Voltage	DC-ON, I _{IL} =-130mA			0.3	V
V _{OH}	"H" Output Voltage	DC-ON, I _{OH} =-10mA	V _{CORE} -0.2			V
V _{OL}	"L" Output Voltage	POWER-EN, I _{OL} =10mA			0.2	V
IPD	Pull-down Current	CHG pin, V _{IN} =1.8V	0.6	1.3	2.6	μA
		ON-OFF, REG3EN, REG1PSB, REG2EN, REG6EN,REG7EN, REG8EN, BUZ-IN, SIM-EN, SIM-SV V _{IN} =1.8V	0.15	0.35	0.60	μA

*Positive current flows into the LSI.