

2.0A/1.5A LDO REGULATOR

NO. EA-125-0601

OUTLINE

The R1171x Series are CMOS-based positive voltage regulator ICs. The R1171x Series have features of low dropout voltage, high output voltage accuracy, low consumption current. Each of these ICs consists of a voltage reference unit, an error amplifier, resistor net for setting output voltage, a current limit circuit at short mode, a chip enable circuit, and thermal-shunt circuit. The output voltage of R1171 is fixed in the IC.

Low consumption current by the merit of CMOS process and built-in transistors with low ON-resistance make low dropout voltage and chip enable function prolongs the battery life. These regulators are remarkable improvement on the current regulators in terms of input transient response, and load transient response.

Thus, the R1171x Series are suitable for various power sources.

Since the packages for these ICs are high wattage HSOP-6J package, TO-252-5L(Under Development), high density mounting of the ICs on boards is possible.

FEATURES

- Low Supply Current Typ. 130 μ A
- Low Standby Current Typ. 0.1 μ A
- Output Current Min. 1.5A ($V_{IN}=V_{OUT}+1.0V$, R1171SxxxA/B)
Min. 2.0A ($V_{IN}=V_{OUT}+1.0V$, R1171JxxxC/D)
(Under Development)
- Output Voltage Stepwise setting with a step of 0.1V in the range of
1.5V to 5.0V for A/B Versions,
1.8V to 5.0V for C/D Versions.
- Output Voltage Accuracy..... $\pm 2.0\%$
- Low Dropout Voltage..... Typ. 0.09V ($V_{OUT}=3.0V$, $I_{OUT}=300mA$)
- Line Regulation Typ. 0.05%/V
- Packages HSOP-6J, TO-252-5L(Under Development)
- Built-in Current Limit Circuit
- Built-in Thermal Shunt Circuit
- Low Temperature-drift Coefficient of Output Voltage ... Typ. $\pm 100ppm/^{\circ}C$
- Ceramic capacitor for phase compensation $C_{IN}=C_{OUT}=\text{Ceramic } 10.0\mu F$ ($V_{OUT}<1.8V$)
 $C_{IN}=C_{OUT}=\text{Ceramic } 4.7\mu F$ ($V_{OUT} \geq 1.8V$)

APPLICATIONS

- Local Power source for Notebook PC.
- Local Power source for portable appliances, cameras, and videos.
- Local Power source for equipment of battery-use.
- Local Power source for home appliances.

BLOCK DIAGRAMS

R1171SxxxA

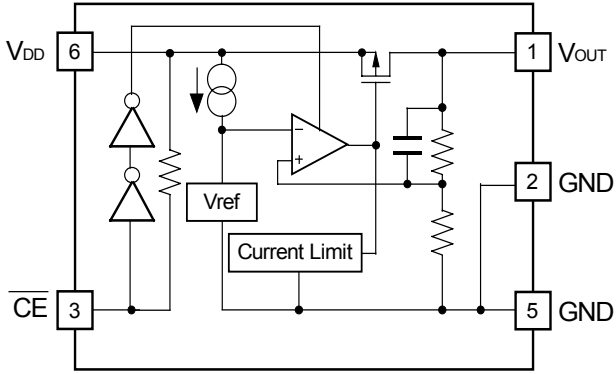

R1171SxxxB

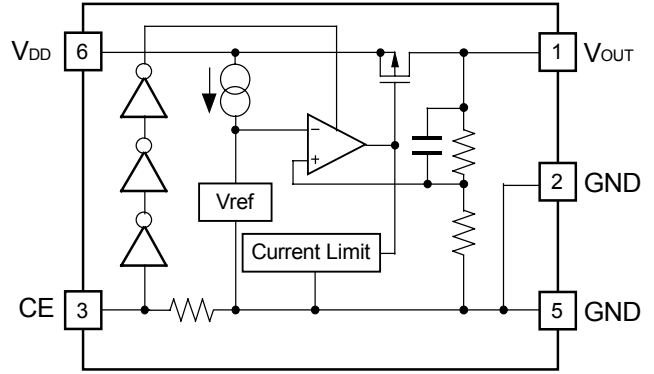

R1171JxxxC (Under Development)

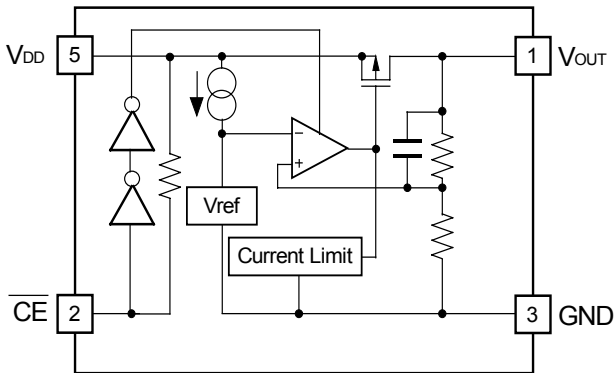

R1171JxxxD (Under Development)

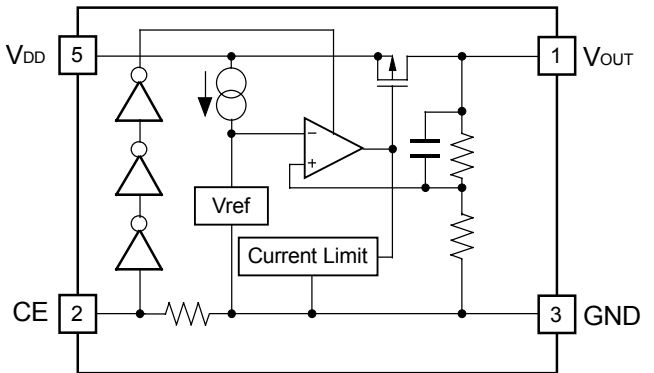

SELECTION GUIDE

The output voltage, the chip-enable polarity, the taping type can be selected at the user's request.
The selection can be made with the part number as follows;

R1171xxx1x-xx ←Part Number
 ↑ ↑ ↑ ↑
 a b c d

Code	Contents
a	Package Type; S: HSOP-6J J: TO-252-5L (Under Development)
b	Designation of Output Voltage (V_{OUT}) Stepwise setting with 0.1V increment in the range from 1.5V to 5.0V(A/B version), from 1.8V to 5.0V(C/D version: Under Development) "Exception" 2.85V type: R1171x281x5-xx, 1.85V Type: R1171x181x5
c	Designation of option; A: Built-in Chip Enable Circuit, Active at "L" (Output Current :Min.1.5A) B: Built-in Chip Enable Circuit, Active at "H" (Output Current :Min.1.5A) C: Built-in Chip Enable Circuit, Active at "L" (Output Current :Min.2.0A)*Under Development D: Built-in Chip Enable Circuit, Active at "H" (Output Current :Min.2.0A)*Under Development
d	Designation of Taping Type; E2 (HSOP-6J) (Refer to Taping Specifications) TO-252-5L : unfixed

PIN CONFIGURATION

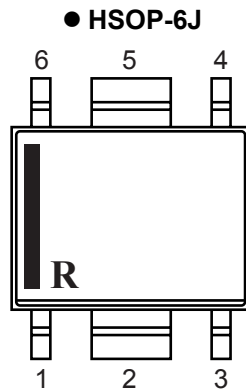

● TO-252-5L (Under Development)

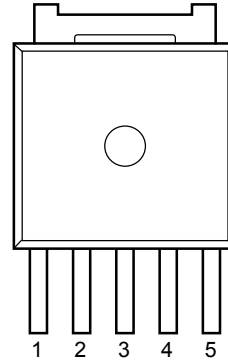

PIN DESCRIPTION

● HSOP-6J

Pin No	Symbol	Description
1	V_{OUT}	Voltage Regulator Output Pin
2	GND	Ground Pin
3	\overline{CE} or CE	Chip Enable Pin
4	NC	No Connection
5	GND	Ground Pin
6	V_{DD}	Input Pin

● TO-252-5L (Under Development)

Pin No	Symbol	Description
1	V_{OUT}	Voltage Regulator Output Pin
2	\overline{CE} or CE	Chip Enable Pin
3	GND	Ground Pin
4	NC	No Connection
5	V_{DD}	Input Pin

ABSOLUTE MAXIMUM RATINGS

Symbol	Item	Rating	Unit
V_{IN}	Input Voltage	7.0	V
V_{CE}	Input Voltage (\overline{CE} or CE Input Pin)	-0.3 ~ $V_{IN}+0.3$	V
V_{OUT}	Output Voltage	-0.3 ~ $V_{IN}+0.3$	V
I_{OUT}	Output Current	3.5	A
P_D	Power Dissipation (HSOP-6J)*1	1700	mW
	Power Dissipation (TO-252-5L)*1	Under Development	
T_{opt}	Operating Temperature	-40 ~ 85	°C
T_{stg}	Storage Temperature	-55 ~ 125	°C

*1 For Power Dissipation, please refer to PACKAGE INFORMATION to be described.

ELECTRICAL CHARACTERISTICS

• R1171Sxx1A

 $T_{opt}=25^{\circ}\text{C}$

Symbol	Item	Conditions	Min.	Typ.	Max.	Unit
V_{OUT}	Output voltage	$V_{IN}-V_{OUT}=1.0\text{V}$ $I_{OUT}=200\text{mA}$	$\times 0.98$		$\times 1.02$	V
I_{OUT}	Output Current	$V_{IN}-V_{OUT}=1.0\text{V}$	1.5			A
$\frac{\Delta V_{OUT}}{\Delta I_{OUT}}$	Load regulation	$V_{IN}-V_{OUT}=1.0\text{V}$ $1\text{mA} \leq I_{OUT} \leq 300\text{mA}$		30	60	mV
V_{DIF}	Dropout Voltage	$I_{OUT}=300\text{mA}$	Refer to Electrical Characteristics by Output Voltage			
I_{SS}	Supply Current	$V_{IN}-V_{OUT} = 1.0\text{V}$ $V_{CE}=\text{GND}$		130	320	μA
$I_{standby}$	Standby Current	$V_{IN}-V_{OUT}=1.0\text{V}$ $V_{IN}=V_{CE}$		0.1	2.0	μA
$\frac{\Delta V_{OUT}}{\Delta V_{IN}}$	Line regulation	$I_{OUT}=200\text{mA}$	Refer to Electrical Characteristics by Output Voltage			
RR	Ripple Rejection	$f=1\text{kHz}$, Ripple 0.5Vp-p				
V_{IN}	Input Voltage		2.1		6.0	V
$\frac{\Delta V_{OUT}}{\Delta T_{opt}}$	Output Voltage Temperature Coefficient	$I_{OUT}=10\text{mA}$ $-40^{\circ}\text{C} \leq T_{opt} \leq 85^{\circ}\text{C}$		± 100		ppm/ $^{\circ}\text{C}$
I_{lim}	Short Current Limit	$V_{OUT}=0\text{V}$		200		mA
R_{PU}	Pull-up resistance for \overline{CE} pin		2.5	5.0	10.0	$\text{M}\Omega$
V_{CEH}	\overline{CE} Input Voltage "H"		1.2		V_{IN}	V
V_{CEL}	\overline{CE} Input Voltage "L"		0.00		0.25	V
T_{TSD}	Thermal Shutdown Detector Threshold Temperature	Junction Temperature		150		$^{\circ}\text{C}$
T_{TSR}	Thermal Shutdown Released Temperature	Junction Temperature		120		$^{\circ}\text{C}$

R1171x

• R1171Sxx1B

T_{opt}=25°C

Symbol	Item	Conditions	Min.	Typ.	Max.	Unit
V _{OUT}	Reference Voltage for Adjustable Voltage Regulator	V _{IN} -V _{OUT} =1.0V I _{OUT} =200mA	×0.98		×1.02	V
I _{OUT}	Output Current	V _{IN} -V _{OUT} =1.0V	1.5			A
$\frac{\Delta V_{OUT}}{\Delta I_{OUT}}$	Load regulation	V _{IN} -V _{OUT} =1.0V 1mA ≤ I _{OUT} ≤ 300mA		30	60	mV
V _{DIF}	Dropout Voltage	I _{OUT} =300mA	Refer to Electrical Characteristics by Output Voltage Table			
I _{SS}	Supply Current	V _{IN} -V _{OUT} =1.0V V _{CE} =V _{IN}		130	320	μA
I _{standby}	Standby Current	V _{IN} -V _{OUT} =1.0V V _{CE} =GND		0.3	1.0	μA
$\frac{\Delta V_{OUT}}{\Delta V_{IN}}$	Line regulation	I _{OUT} =200mA	Refer to Electrical Characteristics by Output Voltage Table			
RR	Ripple Rejection	f=1kHz, Ripple 0.5Vp-p				
V _{IN}	Input Voltage		2.1		6.0	V
$\frac{\Delta V_{OUT}}{\Delta T_{opt}}$	Output Voltage Temperature Coefficient	-40°C ≤ T _{opt} ≤ 85°C		±100		ppm/°C
I _{lim}	Short Current Limit	V _{OUT} =0V		200		mA
R _{PD}	Pull-down resistance for CE pin		2.5	5.0	10.0	MΩ
V _{CEH}	CE Input Voltage "H"		1.2		V _{IN}	V
V _{CEL}	CE Input Voltage "L"		0.00		0.25	V
T _{TSD}	Thermal Shutdown Detector Threshold Temperature	Junction Temperature		150		°C
T _{TSR}	Thermal Shutdown Released Temperature	Junction Temperature		120		°C

• R1171Jxx1C (Under Development)

$T_{opt}=25^{\circ}\text{C}$

Symbol	Item	Conditions	Min.	Typ.	Max.	Unit
V_{OUT}	Output voltage	$V_{IN}-V_{OUT}=1.0\text{V}$ $I_{OUT}=200\text{mA}$	$\times 0.98$		$\times 1.02$	V
I_{OUT}	Output Current	$V_{IN}-V_{OUT}=1.0\text{V}$	2.0			A
$\frac{\Delta V_{OUT}}{\Delta I_{OUT}}$	Load regulation	$V_{IN}-V_{OUT}=1.0\text{V}$ $1\text{mA} \leq I_{OUT} \leq 300\text{mA}$		30	60	mV
V_{DIF}	Dropout Voltage	$I_{OUT}=300\text{mA}$	Refer to Electrical Characteristics by Output Voltage			
I_{SS}	Supply Current	$V_{IN}-V_{OUT}=1.0\text{V}$ $V_{CE}=\text{GND}$		130	320	μA
$I_{standby}$	Standby Current	$V_{IN}-V_{OUT} = 1.0\text{V}$ $V_{IN}=V_{CE}$		0.1	2.0	μA
$\frac{\Delta V_{OUT}}{\Delta V_{IN}}$	Line regulation	$I_{OUT}=200\text{mA}$	Refer to Electrical Characteristics by Output Voltage			
RR	Ripple Rejection	$f=1\text{kHz}$, Ripple 0.5Vp-p				
V_{IN}	Input Voltage		2.1		6.0	V
$\frac{\Delta V_{OUT}}{\Delta T_{opt}}$	Output Voltage Temperature Coefficient	$I_{OUT}=10\text{mA}$ $-40^{\circ}\text{C} \leq T_{opt} \leq 85^{\circ}\text{C}$		± 100		ppm/ $^{\circ}\text{C}$
I_{lim}	Short Current Limit	$V_{OUT}=0\text{V}$		200		mA
R_{PU}	Pull-up resistance for $\overline{\text{CE}}$ pin		2.5	5.0	10.0	$\text{M}\Omega$
V_{CEH}	$\overline{\text{CE}}$ Input Voltage "H"		1.2		V_{IN}	V
V_{CEL}	$\overline{\text{CE}}$ Input Voltage "L"		0.00		0.25	V
T_{TSD}	Thermal Shutdown Detector Threshold Temperature	Junction Temperature		150		$^{\circ}\text{C}$
T_{TSR}	Thermal Shutdown Released Temperature	Junction Temperature		120		$^{\circ}\text{C}$

R1171x

• R1171Jxx1D (Under Development)T_{opt}=25°C

Symbol	Item	Conditions	Min.	Typ.	Max.	Unit
V _{OUT}	Reference Voltage for Adjustable Voltage Regulator	V _{IN} -V _{OUT} =1.0V I _{OUT} =200mA	×0.98		×1.02	V
I _{OUT}	Output Current	V _{IN} -V _{OUT} =1.0V	2.0			A
ΔV _{OUT} / ΔI _{OUT}	Load regulation	V _{IN} -V _{OUT} =1.0V 1mA ≤ I _{OUT} ≤ 300mA		30	60	mV
V _{DIF}	Dropout Voltage	I _{OUT} =300mA	Refer to Electrical Characteristics by Output Voltage			
I _{SS}	Supply Current	V _{IN} -V _{OUT} =1.0V, V _{CE} =V _{IN}		130	320	μA
I _{standby}	Standby Current	V _{IN} -V _{OUT} =1.0V, V _{CE} =GND		0.1	2.0	μA
ΔV _{OUT} / ΔV _{IN}	Line regulation	I _{OUT} =200mA	Refer to Electrical Characteristics by Output Voltage			
RR	Ripple Rejection	f=1kHz, Ripple 0.5Vp-p				
V _{IN}	Input voltage		2.1		6.0	V
ΔV _{OUT} / ΔT _{opt}	Output Voltage Temperature Coefficient	I _{OUT} =10mA -40°C ≤ T _{opt} ≤ 85°C		±100		ppm/°C
I _{lim}	Short Current Limit	V _{OUT} =0V		200		mA
R _{PD}	Pull-down resistance for CE pin		2.5	5.0	10.0	MΩ
V _{CEH}	CE Input Voltage "H"		1.2		V _{IN}	V
V _{CEL}	CE Input Voltage "L"		0.00		0.25	V
T _{TSD}	Thermal Shutdown Detector Threshold Temperature	Junction Temperature		150		°C
T _{TSR}	Thermal Shutdown Released Temperature	Junction Temperature		120		°C

• Electrical Characteristics by Output Voltage (T_{opt}=25°C)

Output Voltage V _{OUT} (V)	Dropout Voltage (V)	
	Typ.	Max.
$1.5 \leq V_{OUT} < 1.6$	0.16	0.35
$1.6 \leq V_{OUT} < 1.7$	0.14	0.32
$1.7 \leq V_{OUT} < 1.8$	0.13	0.28
$1.8 \leq V_{OUT} < 2.0$	0.12	0.24
$2.0 \leq V_{OUT} < 2.5$	0.10	0.21
$2.5 \leq V_{OUT} \leq 5.0$	0.09	0.18

Output Voltage V _{OUT} (V)	Load regulation $\Delta V_{OUT}/\Delta V_{IN}$ (%/V)		
	Condition	Typ.	Max.
$1.5 \leq V_{OUT} < 1.6$	$2.1 \leq V_{OUT} < 6.0$	0.05	0.30
$1.6 \leq V_{OUT} \leq 5.0$	$V_{OUT} + 0.5V \leq V_{IN} \leq 6.0V$		

Output Voltage V _{OUT} (V)	Ripple Rejection RR (dB)	
	Condition	Typ.
$1.5 \leq V_{OUT} < 4.7$	$V_{IN} - V_{OUT} = 1.0V$	50
$4.7 \leq V_{OUT} \leq 5.0$	$V_{IN} = 5.75V$	

TEST CIRCUITS

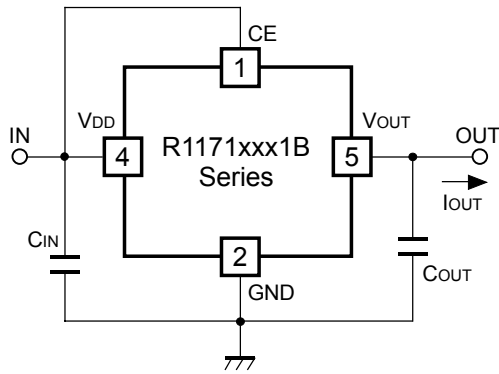

Standard Test Circuit

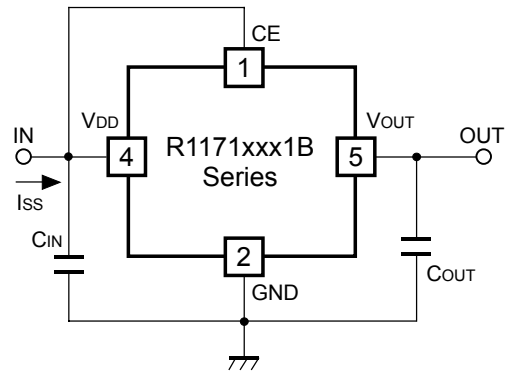

Supply Current Test Circuit

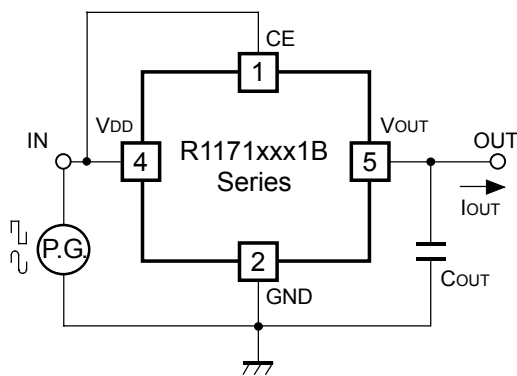

Test Circuit for Ripple Rejection,
Input Transient Response

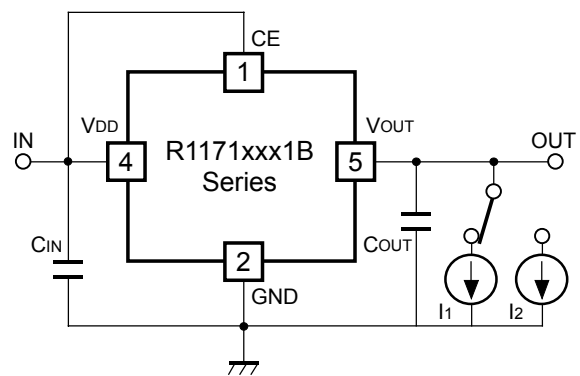

Test Circuit for Load Transient Response

TYPICAL CHARACTERISTICS

1) Output Voltage vs. Output Current (Topt=25°C)

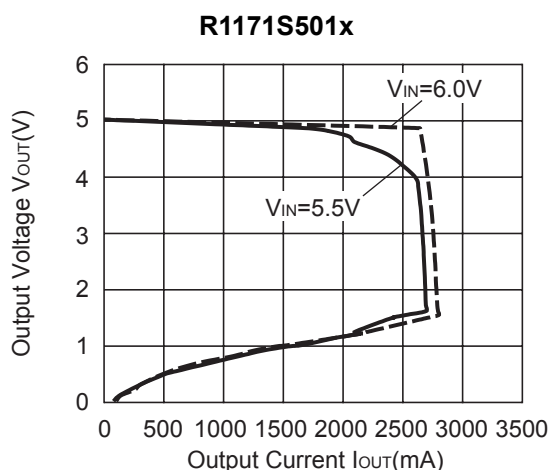
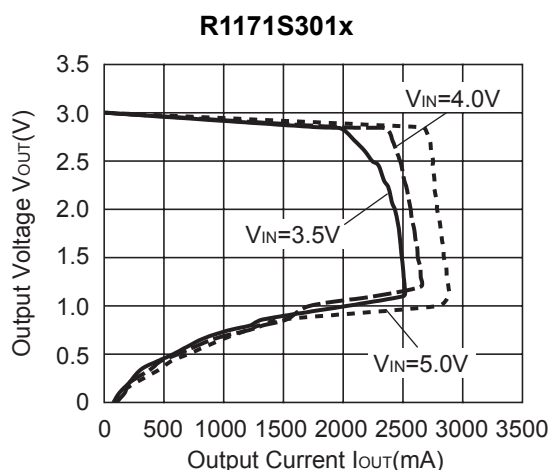
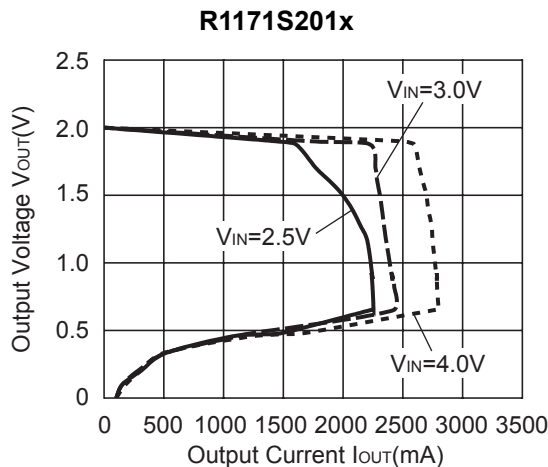
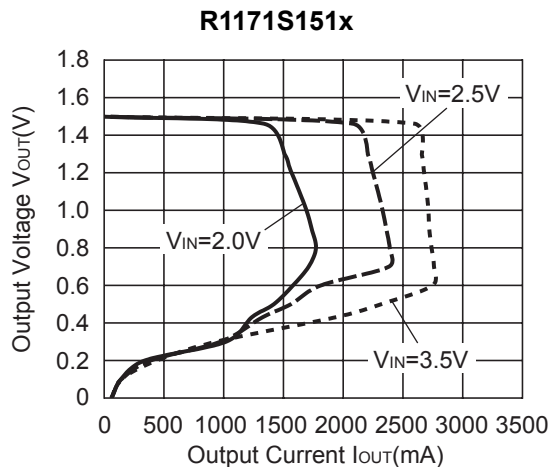

2) Output Voltage vs. Input Voltage (Topt=25°C)

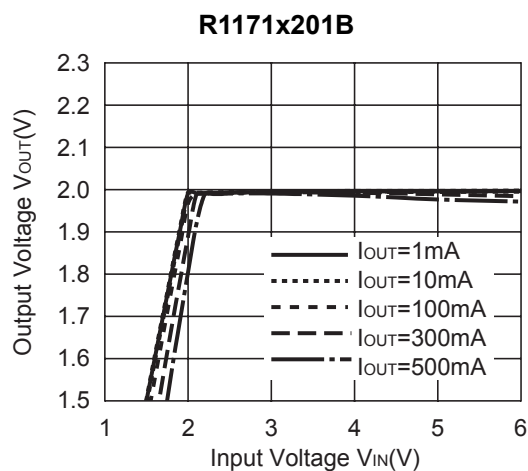
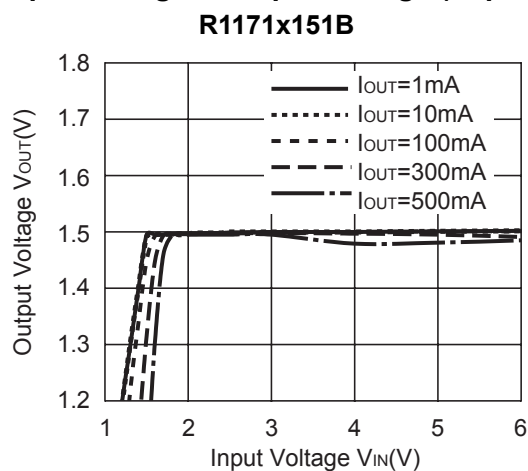

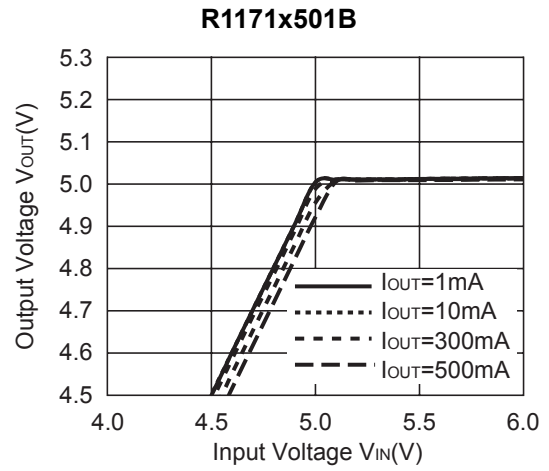
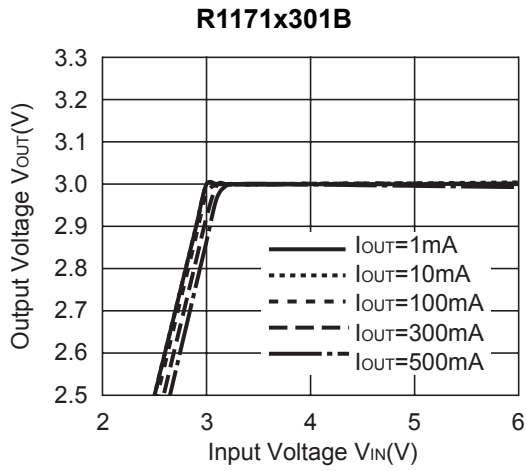

3) Dropout Voltage vs. Output Current

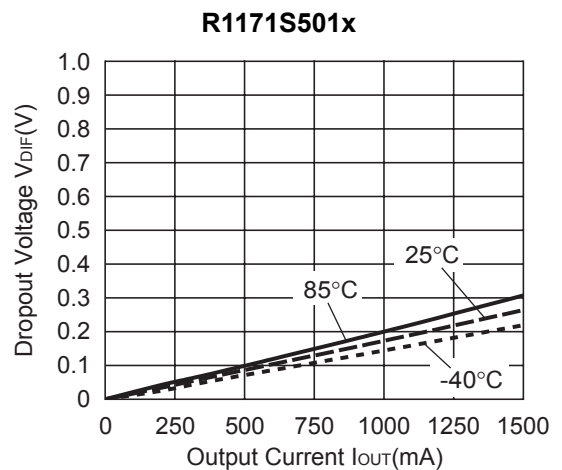
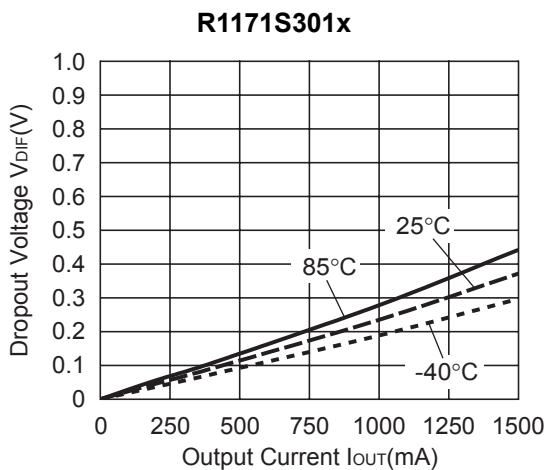
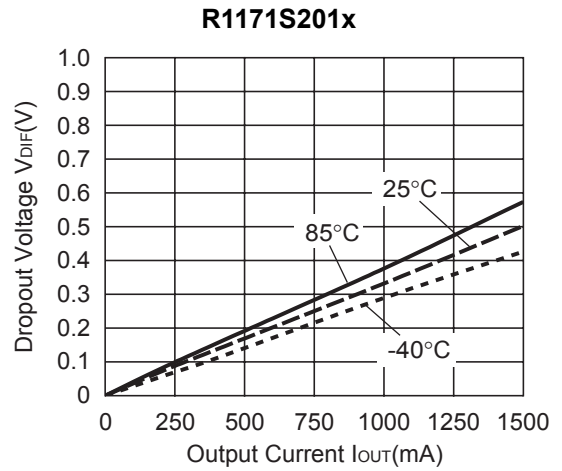
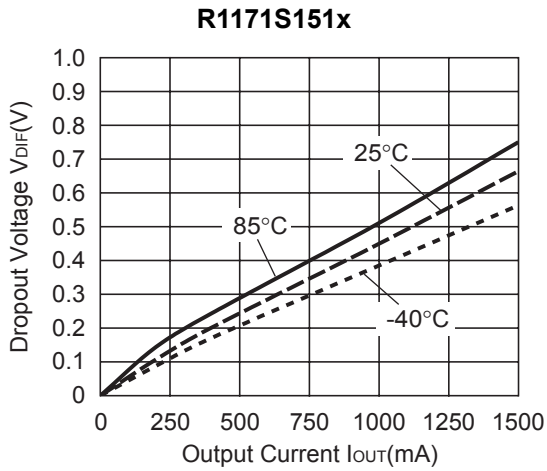

4) Output Voltage vs. Temperature

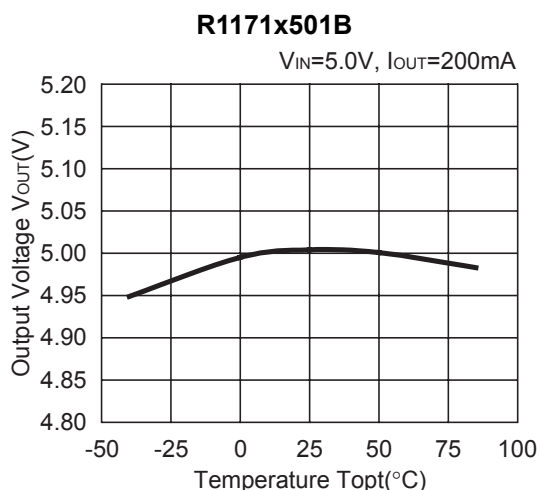
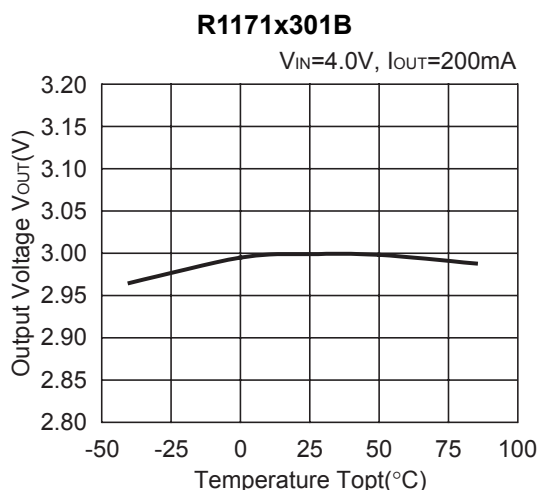
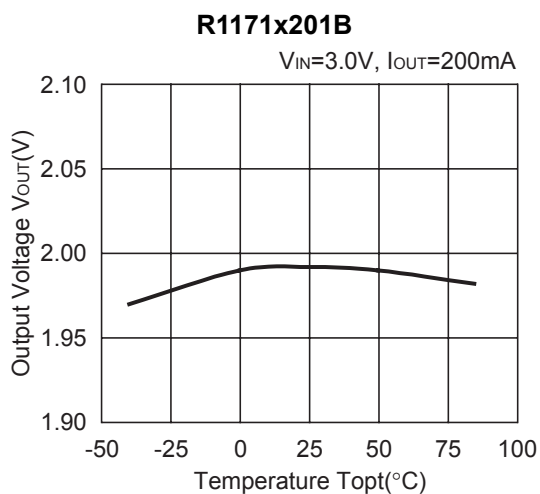
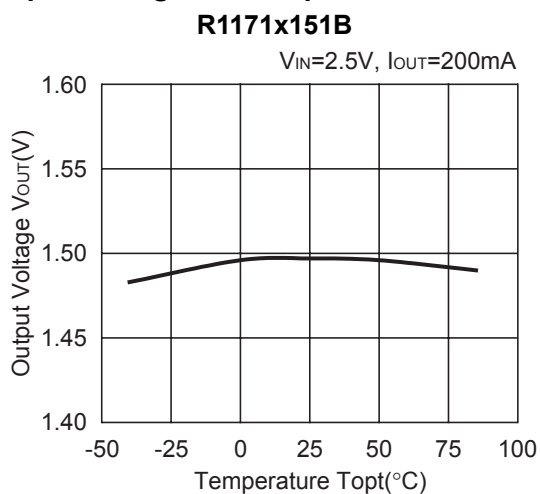

5) Supply Current vs. Input Voltage ($T_{opt}=25^{\circ}C$)

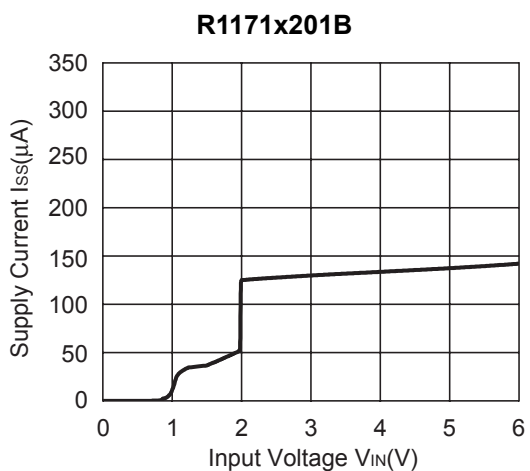
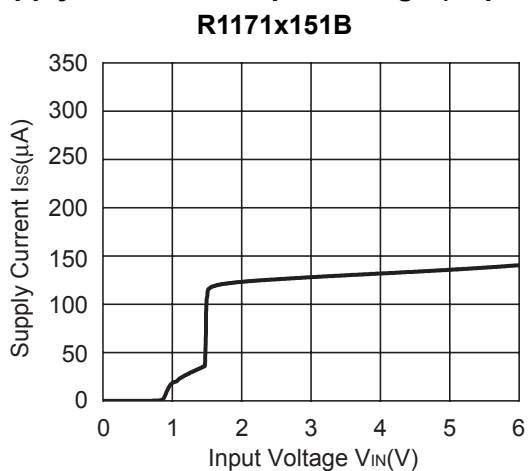

R1171x

R1171x301B

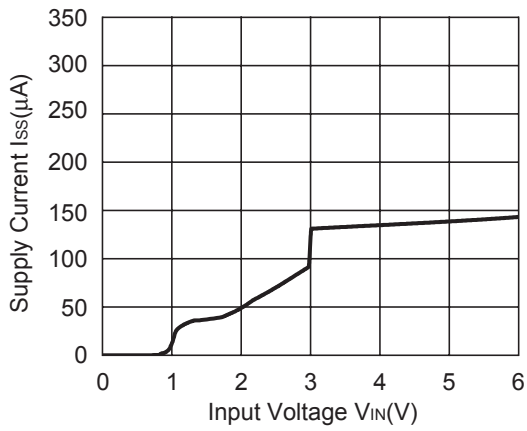

R1171x501B

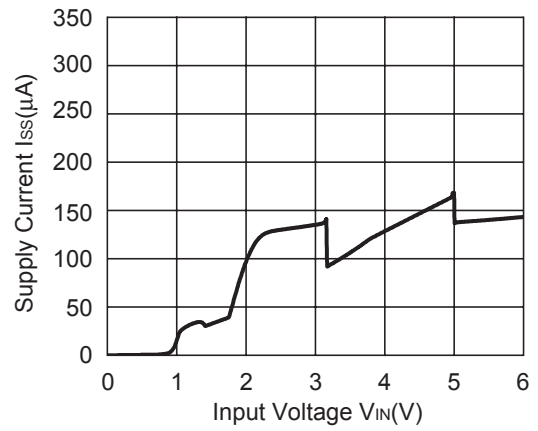

6) Supply Current vs. Temperature

R1171x151B

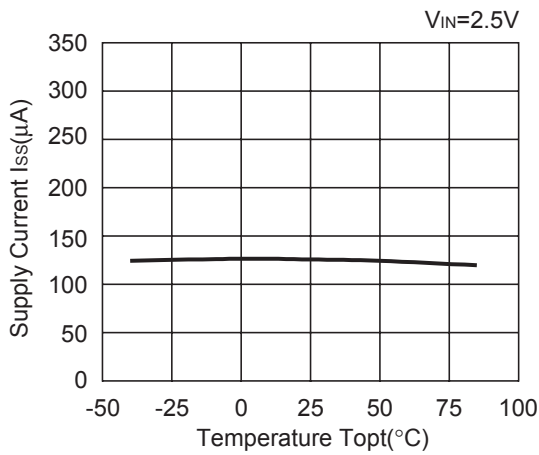

R1171x201B

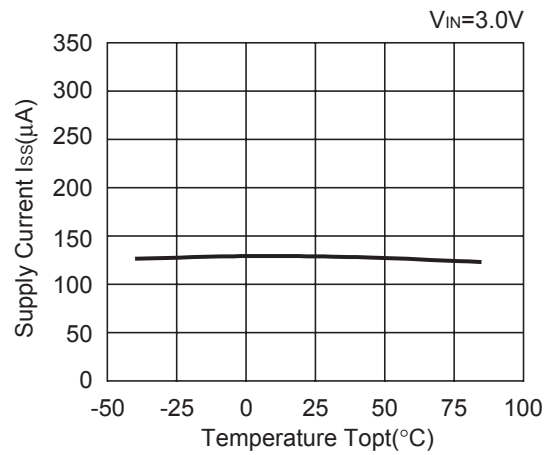

R1171x301B

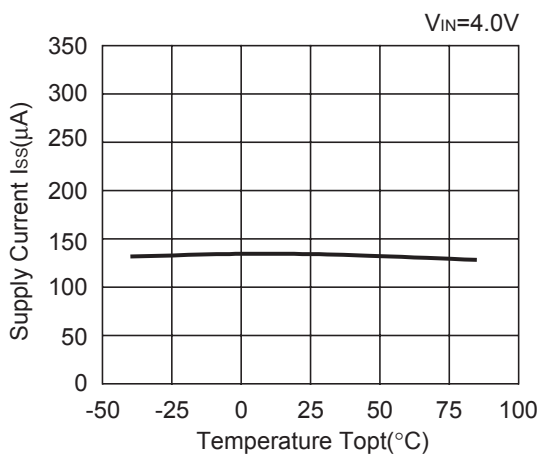

R1171x501B

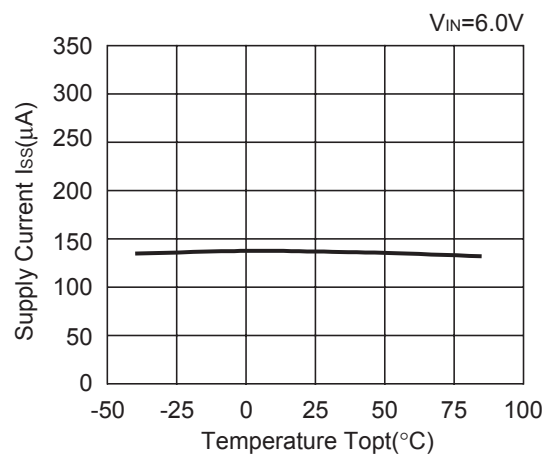

7) Dropout Voltage vs. Set Output Voltage (Topt=25°C)

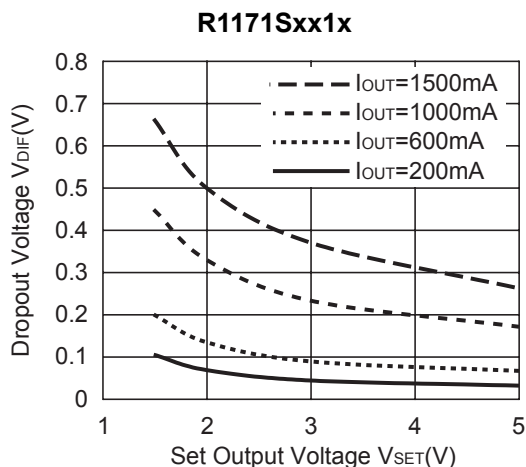

8) Ripple Rejection vs. Frequency

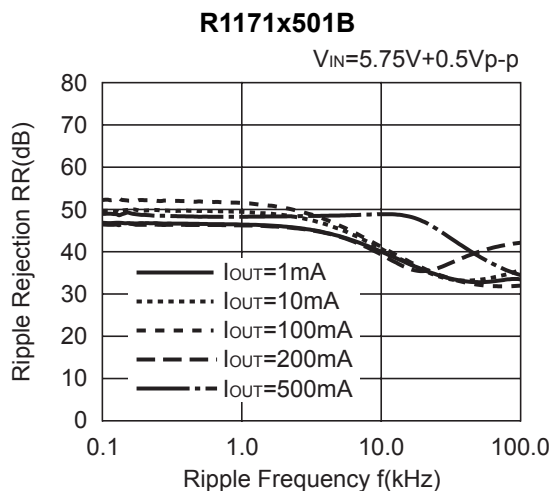
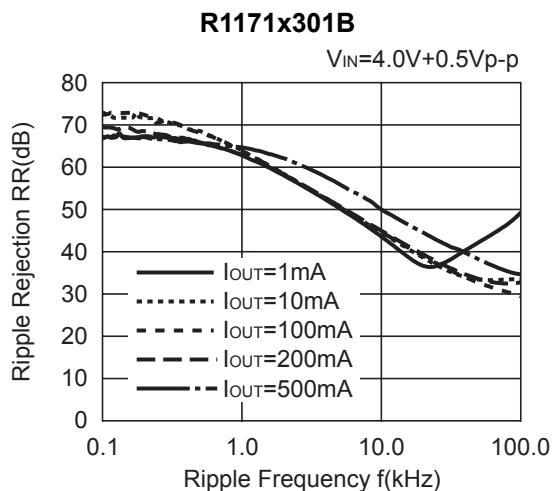
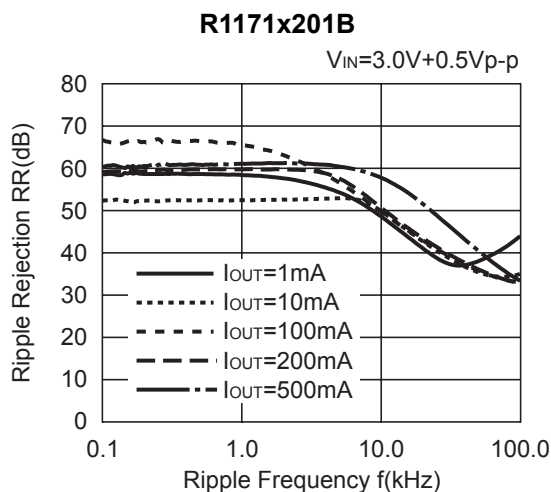
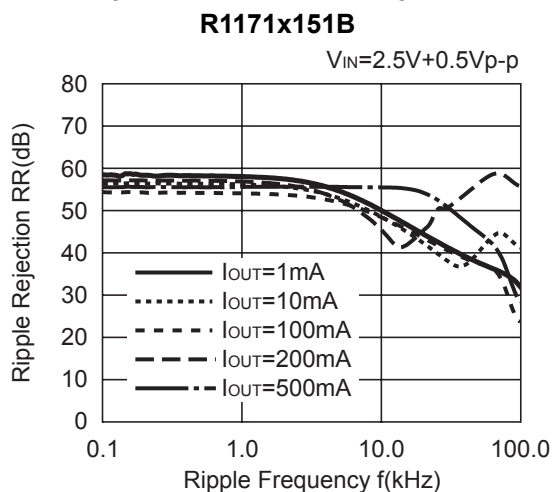

9) Ripple Rejection vs. Input Voltage

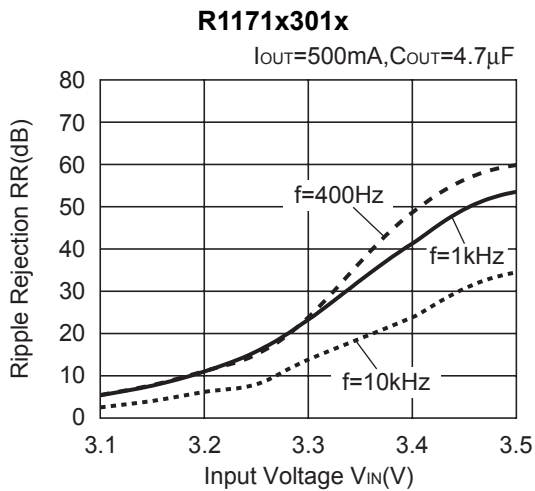
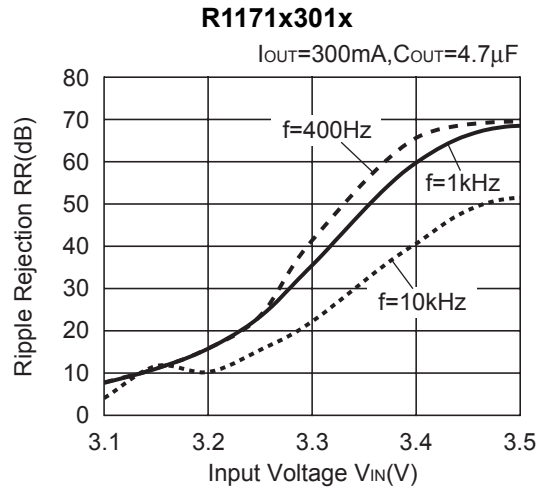
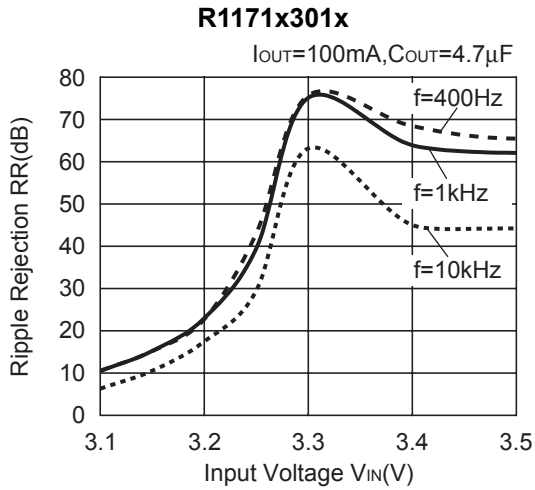
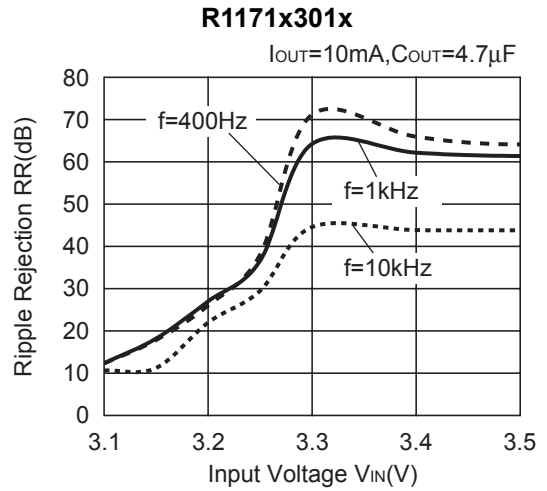
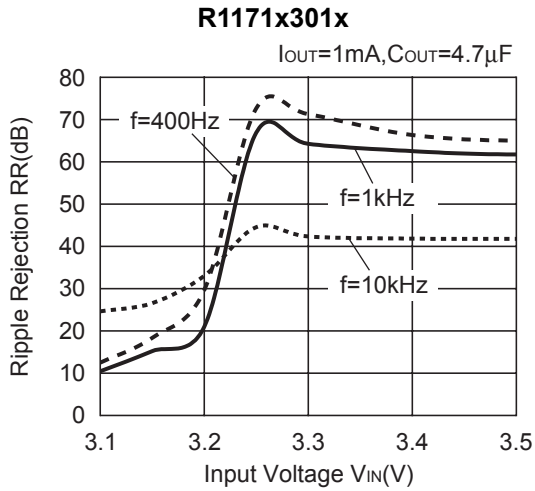

10) Input Transient Response (T_{opt}=25°C)

R1171x151B

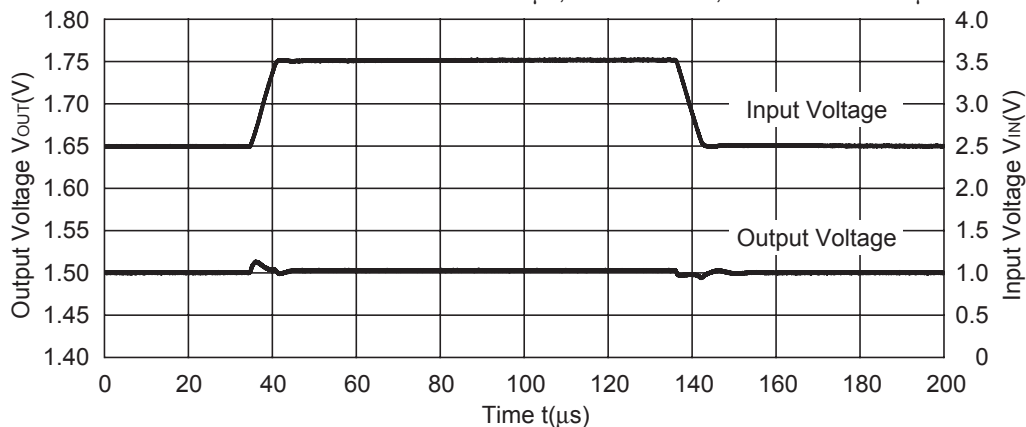
tr=tf=5μs, I_{OUT}=1000mA, C_{OUT}=Ceramic 10μF

R1171x201B

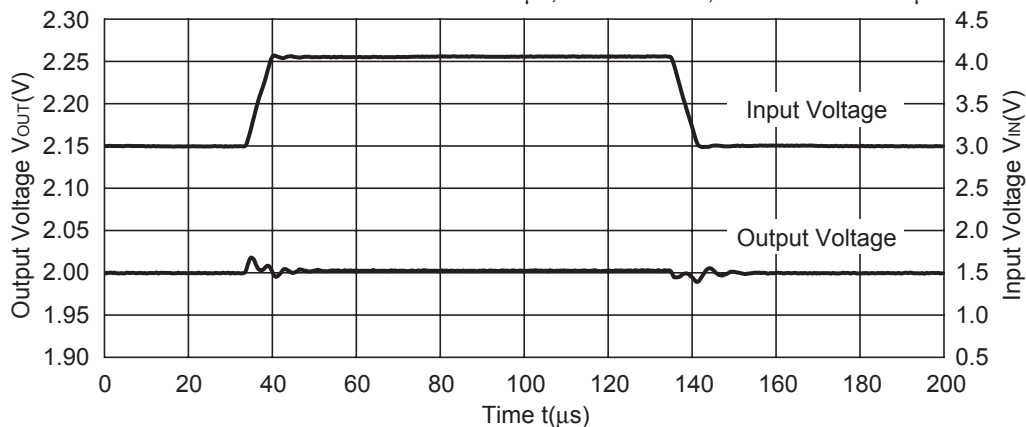
tr=tf=5μs, I_{OUT}=1000mA, C_{OUT}=Ceramic 4.7μF

R1171x301B

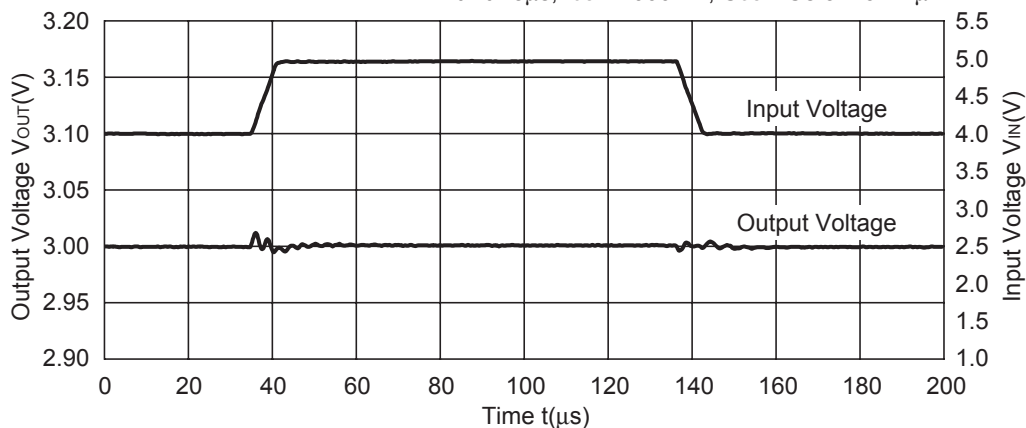
tr=tf=5μs, I_{OUT}=1000mA, C_{OUT}=Ceramic 4.7μF

R1171x501B

$t_r=t_f=5\mu s$, $I_{OUT}=1000mA$, $C_{OUT}=\text{Ceramic } 4.7\mu F$

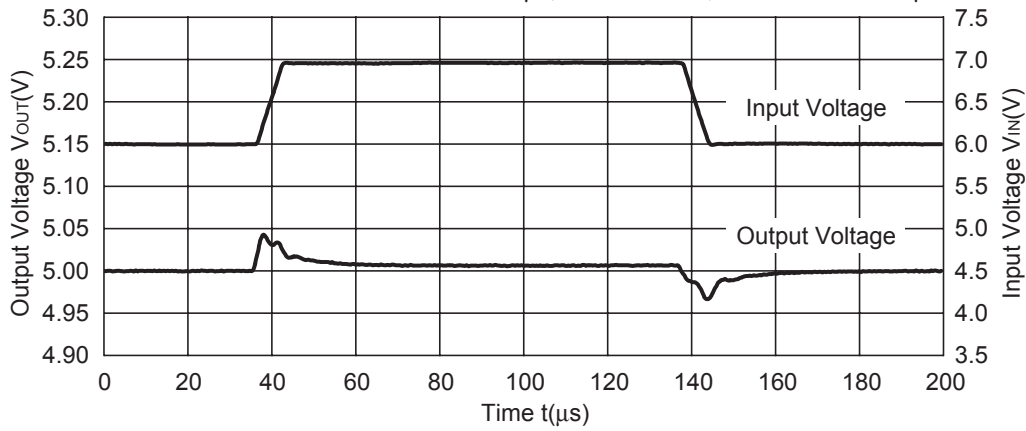

11) Load Transient Response ($T_{opt}=25^{\circ}C$)

R1171x151B

$t_r=t_f=10\mu s$, $V_{IN}=2.5V$, $C_{OUT}=\text{Ceramic } 10\mu F$

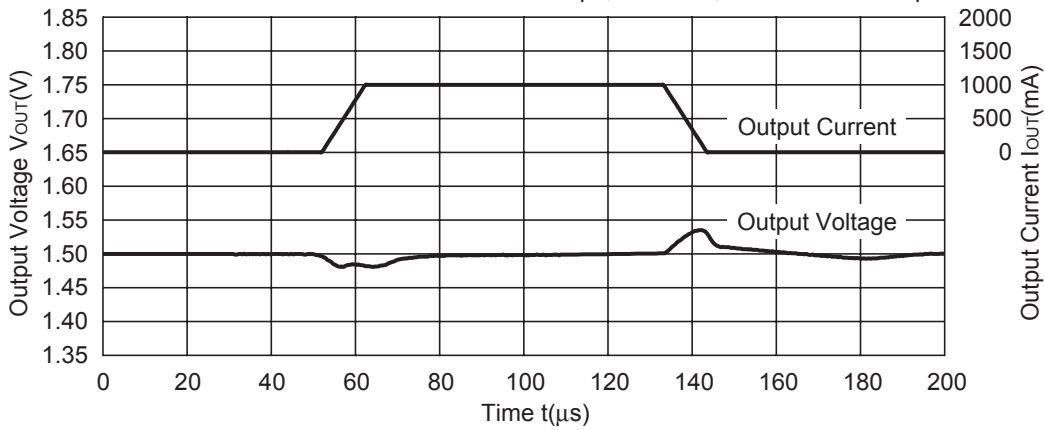

R1171x201B

$t_r=t_f=10\mu s$, $V_{IN}=3.0V$, $C_{OUT}=\text{Ceramic } 4.7\mu F$

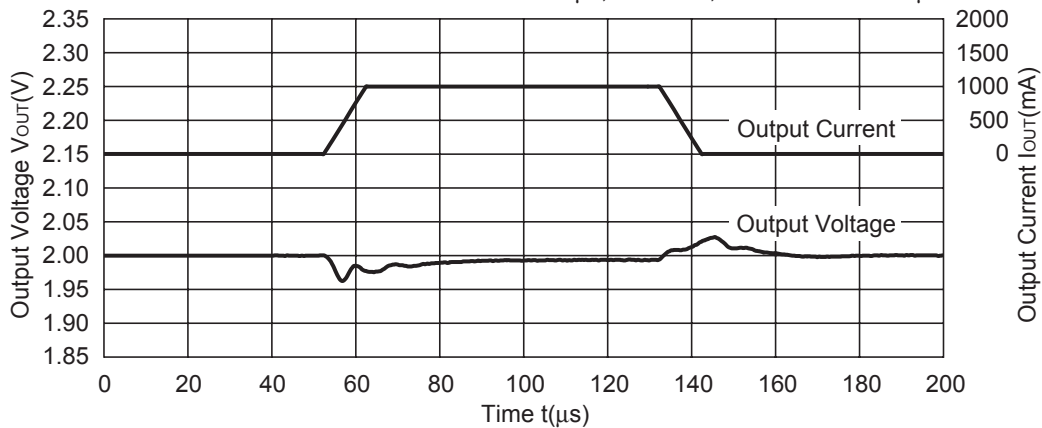

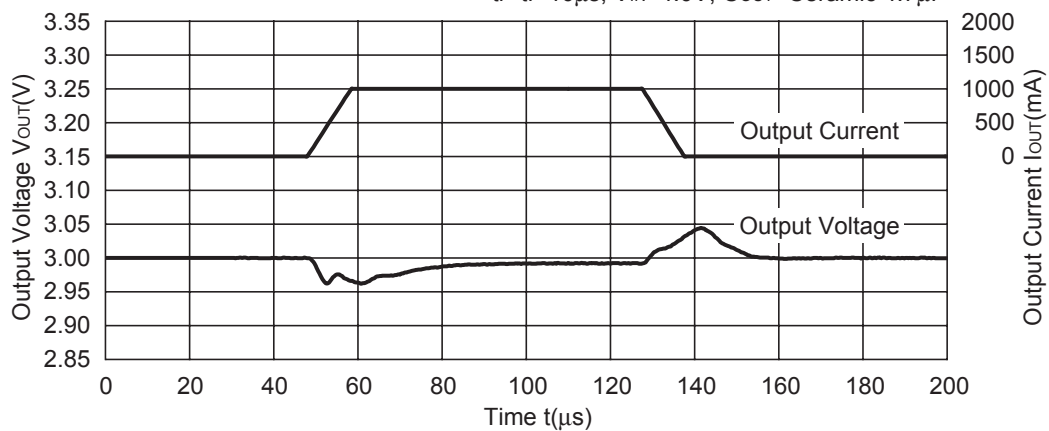
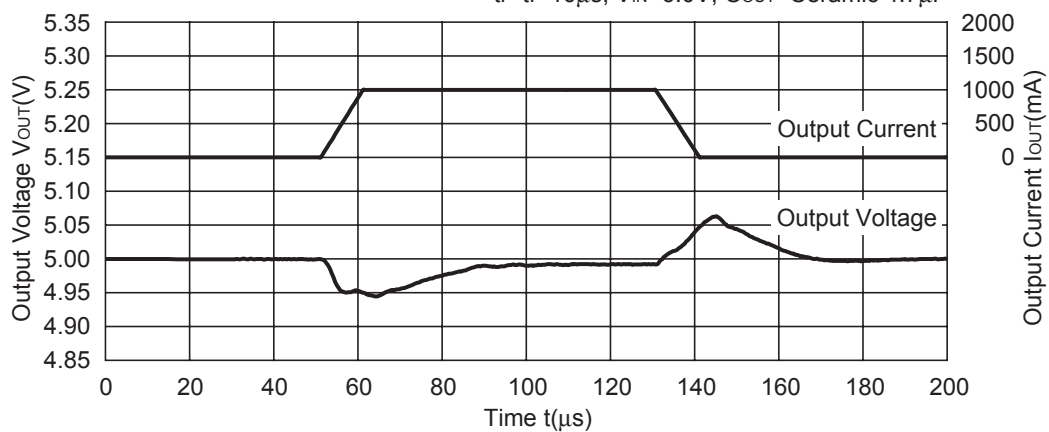
R1171x301B $t_r=t_f=10\mu\text{s}$, $V_{IN}=4.0\text{V}$, $C_{OUT}=\text{Ceramic } 4.7\mu\text{F}$ **R1171x501B** $t_r=t_f=10\mu\text{s}$, $V_{IN}=6.0\text{V}$, $C_{OUT}=\text{Ceramic } 4.7\mu\text{F}$ 

Technical Notes on External Components and Typical Application

1. Phase Compensation

In these ICs, phase compensation is made with the output capacitor for securing stable operation even if the load current is varied. For this purpose, use a capacitor with the capacitance range from $4.7\mu\text{F}$ to $10.0\mu\text{F}$, as C_L . In case that using a tantalum capacitor and the ESR of the tantalum capacitor is too large, unstable operation may result. Fully evaluation is necessary for the whole circuit with considering the frequency characteristic.

2. Mounting on PCB

Make V_{DD} and GND lines sufficient. If their impedance is high, large current may flow and the pick-up noise or unstable operation may result. Therefore use a capacitor with a capacitance range from $4.7\mu\text{F}$ to $10.0\mu\text{F}$ between V_{DD} pin and GND pin as close as possible.

Further, set an output capacitor between V_{OUT} pin and GND pin for phase compensation as close as possible. (Refer to the example of typical application)

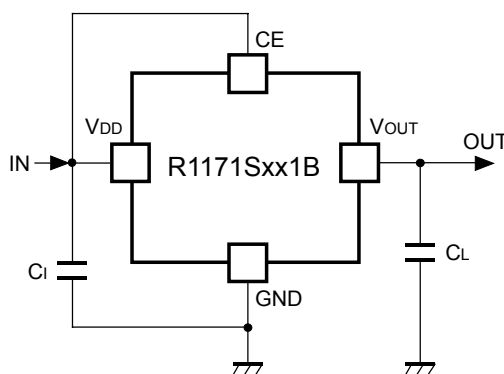

R1171Sxx1B Typical Application

$1.5\text{V} \leq V_{OUT} < 1.8\text{V}$: $C_i=10\mu\text{F}$ (Ceramic), $C_L=10\mu\text{F}$ (Ceramic)

$1.8\text{V} \leq V_{OUT} \leq 5.0\text{V}$: $C_i=4.7\mu\text{F}$ (Ceramic), $C_L=4.7\mu\text{F}$ (Ceramic)

3. Output Short Protection Function

In the R1171x Series, the output short protection function is built in, further, if the output is short to the GND or other voltage line, the chip inside is heating, as a result, in case that the junction temperature becomes equal or more than 150°C (Typ.), the built-in thermal shutdown circuit works. If the junction temperature becomes equal or more than 150°C (Typ.), the IC is protected by the output short protection circuit and the thermal shutdown circuit.

ESR vs. Output Current (T_{opt}=25°C, V_{IN} = Set Output Voltage+1V, C_{IN} = Ceramic 10μF)

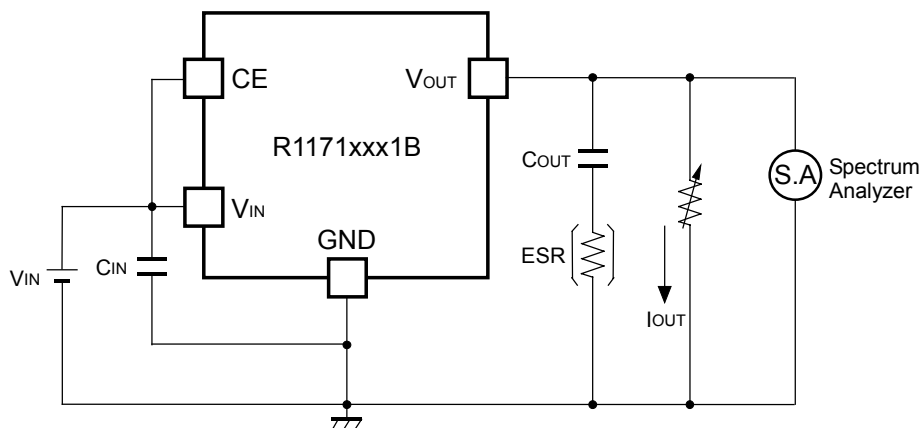

As an output capacitor for this IC, Ceramic capacitor is recommendable. However, other low ESR type capacitor can be used with this IC.

For your reference, noise level is tested with the circuit as shown above, and if the noise level is $40\mu\text{V}$ or less than $40\mu\text{V}$, the ESR values are plotted as stable area. Upper limit is described in the next four graphs, or ESR vs. Output Current. (Hatched area is the stable area.)

R1171S151x

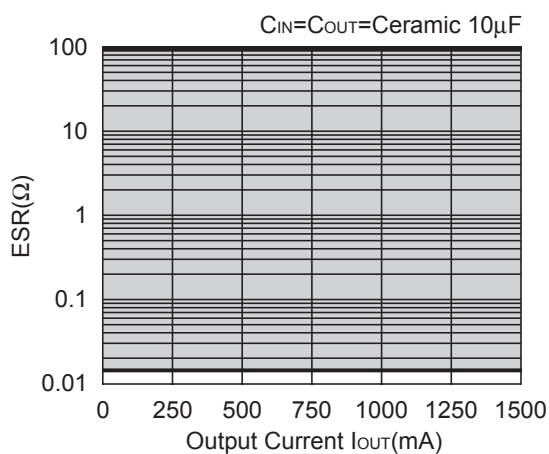

R1171S151x

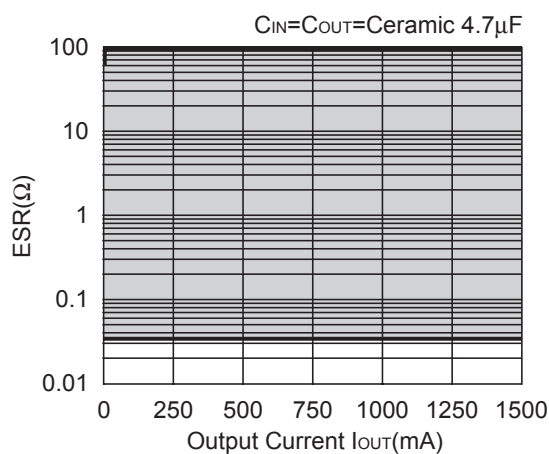

R1171S301x

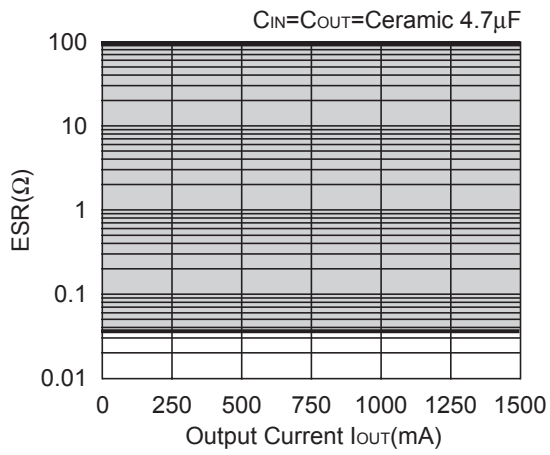

R1171S301x

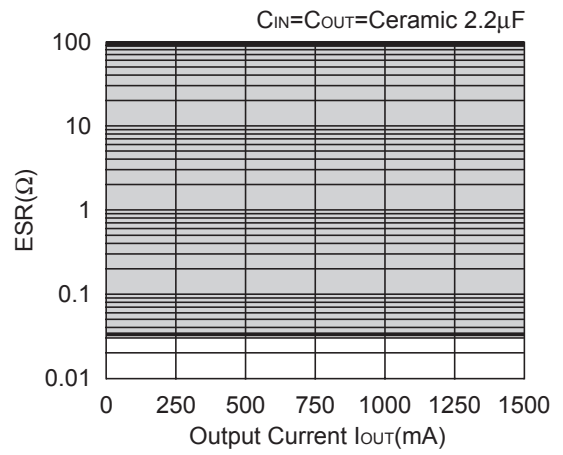

R1171S501x

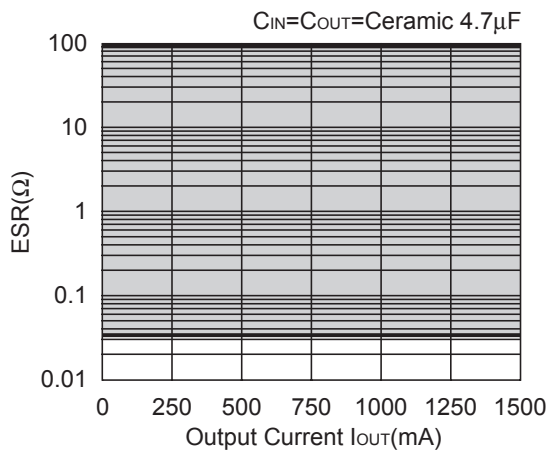

R1171S501x

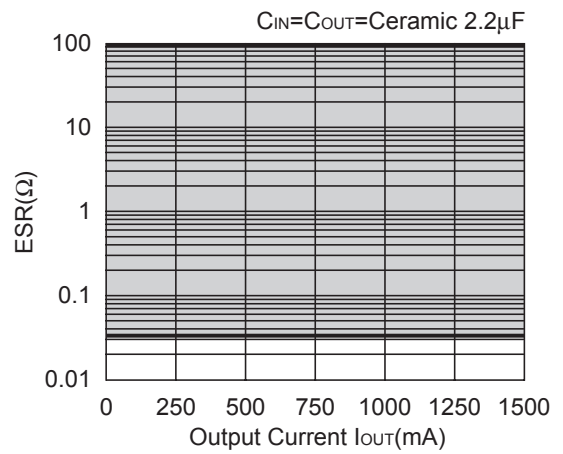

• HSOP-6J

Unit: mm

PACKAGE DIMENSIONS

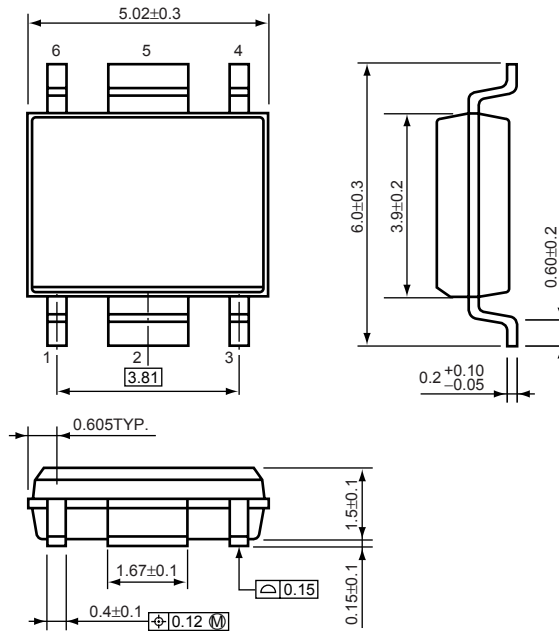

TAPING SPECIFICATION

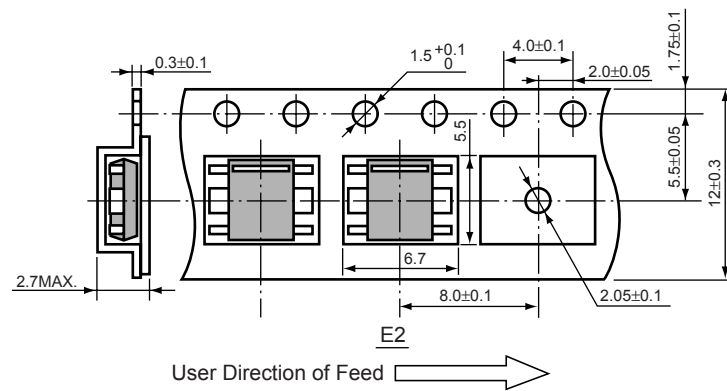

TAPING REEL DIMENSIONS

(1reel=1000pcs)

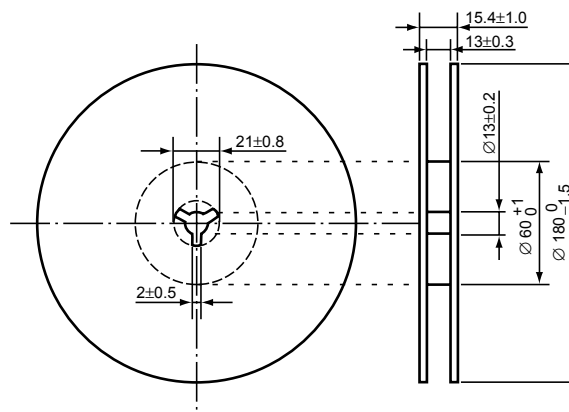

POWER DISSIPATION (HSOP-6J)

This specification is at mounted on board. Power Dissipation (P_D) depends on conditions of mounting on board. This specification is based on the measurement at the condition below:

Measurement Conditions

	High Wattage Land Pattern	Standard Land Pattern
Environment	Mounting on Board (Wind velocity=0m/s)	Mounting on Board (Wind velocity=0m/s)
Board Material	Glass cloth epoxy plactic (Double sided)	Glass cloth epoxy plactic (Double sided)
Board Dimensions	50mm × 50mm × 1.6mm	50mm × 50mm × 1.6mm
Copper Ratio	90%	50%
Through-hole	φ0.5mm × 44pcs	φ0.5mm × 44pcs

Measurement Result

($T_{opt}=25^{\circ}C, T_{jmax}=125^{\circ}C$)

	High Wattage Land Pattern	Standard Land Pattern	Free Air
Power Dissipation	2000mW	1700mW	540mW
Thermal Resistance	50°C/W	59°C/W	185°C/W

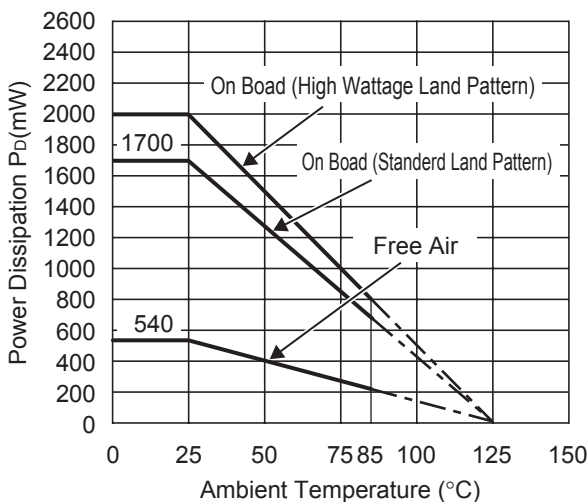

Power Dissipation

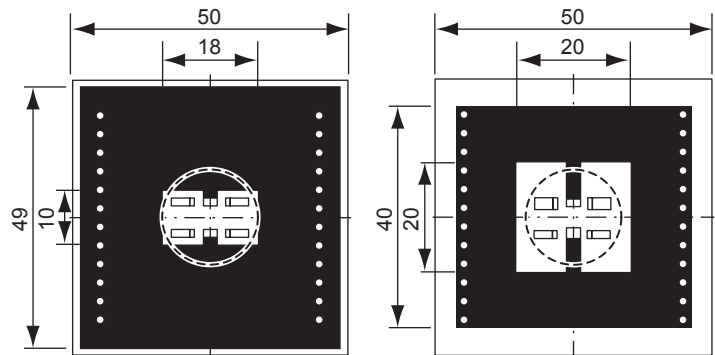

High Wattage

Standard

Measurement Board Pattern

○ IC Mount Area Unit : mm

RECOMMENDED LAND PATTERN

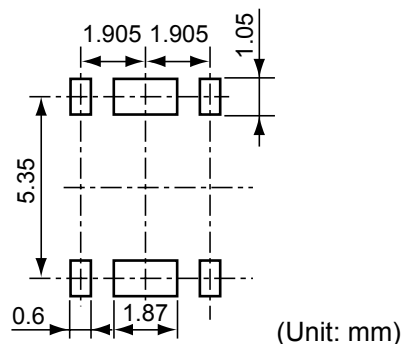

(Unit: mm)

R1171S SERIES MARK SPECIFICATION

● HSOP-6J

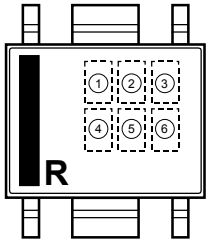

- ① : D (fixed)
- ②, ③ : Setting Voltage } (refer to Part Number vs. Product Code)
- ④ : Type (A,B)
- ⑤, ⑥ : Lot Number

● Part Number vs. Product Code

Part Number	Product Code			
	①	②	③	④
R1171S151A	D	1	5	A
R1171S161A	D	1	6	A
R1171S171A	D	1	7	A
R1171S181A	D	1	8	A
R1171S191A	D	1	9	A
R1171S201A	D	2	0	A
R1171S211A	D	2	1	A
R1171S221A	D	2	2	A
R1171S231A	D	2	3	A
R1171S241A	D	2	4	A
R1171S251A	D	2	5	A
R1171S261A	D	2	6	A
R1171S271A	D	2	7	A
R1171S281A	D	2	8	A
R1171S291A	D	2	9	A
R1171S301A	D	3	0	A
R1171S311A	D	3	1	A
R1171S321A	D	3	2	A
R1171S331A	D	3	3	A

Part Number	Product Code			
	①	②	③	④
R1171S341A	D	3	4	A
R1171S351A	D	3	5	A
R1171S361A	D	3	6	A
R1171S371A	D	3	7	A
R1171S381A	D	3	8	A
R1171S391A	D	3	9	A
R1171S401A	D	4	0	A
R1171S411A	D	4	1	A
R1171S421A	D	4	2	A
R1171S431A	D	4	3	A
R1171S441A	D	4	4	A
R1171S451A	D	4	5	A
R1171S461A	D	4	6	A
R1171S471A	D	4	7	A
R1171S481A	D	4	8	A
R1171S491A	D	4	9	A
R1171S501A	D	5	0	A
R1171S181A5	D	0	1	A
R1171S281A5	D	0	2	A

Part Number	Product Code			
	①	②	③	④
R1171S151B	D	1	5	B
R1171S161B	D	1	6	B
R1171S171B	D	1	7	B
R1171S181B	D	1	8	B
R1171S191B	D	1	9	B
R1171S201B	D	2	0	B
R1171S211B	D	2	1	B
R1171S221B	D	2	2	B
R1171S231B	D	2	3	B
R1171S241B	D	2	4	B
R1171S251B	D	2	5	B
R1171S261B	D	2	6	B
R1171S271B	D	2	7	B
R1171S281B	D	2	8	B
R1171S291B	D	2	9	B
R1171S301B	D	3	0	B
R1171S311B	D	3	1	B
R1171S321B	D	3	2	B
R1171S331B	D	3	3	B

Part Number	Product Code			
	①	②	③	④
R1171S341B	D	3	4	B
R1171S351B	D	3	5	B
R1171S361B	D	3	6	B
R1171S371B	D	3	7	B
R1171S381B	D	3	8	B
R1171S391B	D	3	9	B
R1171S401B	D	4	0	B
R1171S411B	D	4	1	B
R1171S421B	D	4	2	B
R1171S431B	D	4	3	B
R1171S441B	D	4	4	B
R1171S451B	D	4	5	B
R1171S461B	D	4	6	B
R1171S471B	D	4	7	B
R1171S481B	D	4	8	B
R1171S491B	D	4	9	B
R1171S501B	D	5	0	B
R1171S181B5	D	0	1	B
R1171S281B5	D	0	2	B