

## OUTLINE

The R1172x Series are CMOS-based positive voltage regulator ICs. The R1172x Series have features of super low dropout, 1A output current capability. Even the output voltage is set at 1.5V, on resistance of internal FET is typically 0.32Ω. Therefore, applications that require a large current at small dropout are suitable for the R1172x series. Low input voltage is acceptable and low output voltage can be set. The minimum input voltage is 1.4V, and the lowest set output voltage is 0.8V. Each of these ICs consists of a voltage reference unit, an error amplifier, resistor net for setting output voltage, a current limit circuit at over-current, a chip enable circuit, a thermal-shutdown circuit, and so on. A stand-by mode with ultra low consumption current can be realized with the chip enable pin. The output voltage of R1172 is fixed in the IC.

Since the packages for these ICs are SOT-23-5, SOT-89-5, HSON-6, and HSOP-6J with high power dissipation, high density mounting of the ICs on boards is possible.

## FEATURES

- Ultra-Low Supply Current..... Typ. 60μA
- Good Load Regulation ..... Typ. 15mV at I<sub>OUT</sub>=300mA, Typ. 50mV at I<sub>OUT</sub>=1A
- Low inrush current at turning-on ..... Min. 500 mA
- Minimum Operating Voltage..... Min. 1.4V
- Low Standby Current ..... Typ. 0.1μA
- Output Current ..... Max. 1A
- Output Voltage ..... Stepwise setting with a step of 0.1V in the range of 0.8V to 5.0V ( Except HSOP-6J type, 0.8V to 3.5V setting is available for HSOP-6J )
- High Output Voltage Accuracy ..... ±2.0%
- High Power Supply Ripple Rejection ..... Typ. 70dB (V<sub>OUT</sub>=3V)
- Low Dropout Voltage..... Typ. 0.18V (V<sub>OUT</sub>=3.0V, I<sub>OUT</sub>=1A)  
Typ. 0.32V (V<sub>OUT</sub>=1.5V, I<sub>OUT</sub>=1A)
- Line Regulation ..... Typ. 0.05%/V
- Packages ..... SOT-23-5, SOT-89-5, HSON-6,  
High power-HSOP-6J
- Built-in Current Limit Circuit
- Built-in Thermal Shutdown Circuit
- Low Temperature-drift Coefficient of Output Voltage ... Typ. ±100ppm/°C
- Output capacitors ..... C<sub>IN</sub>=C<sub>OUT</sub>=Tantalum 4.7μF (V<sub>OUT</sub><1.0V)  
C<sub>IN</sub>=C<sub>OUT</sub>=Ceramic 4.7μF (V<sub>OUT</sub> ≥ 1.0V)

## APPLICATIONS

- Local Power source for Notebook PC.
- Local Power source for portable communication equipments, cameras, and videos.
- Local Power source for home appliances.

## BLOCK DIAGRAMS

R1172xxx1A

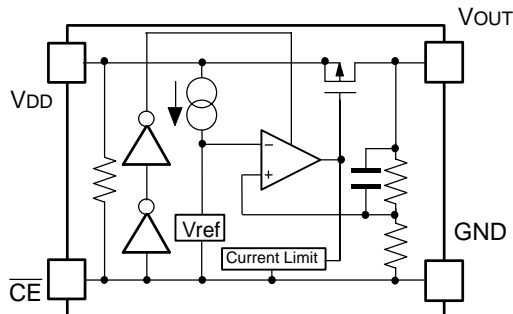

R1172xxx1B

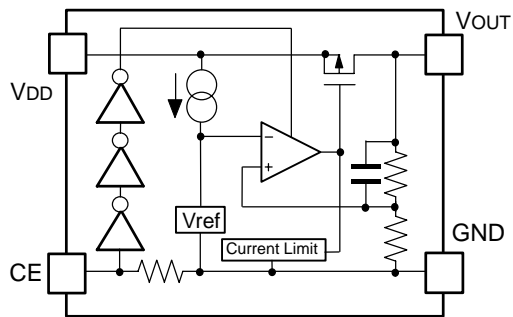

R1172xxx1D

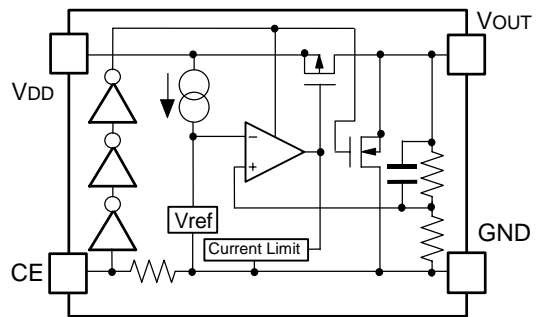

## SELECTION GUIDE

The output voltage, with/without auto-discharge function, the package type, etc. can be selected at the user's request. The selection can be made with the part number as follows;

R1172xxx1x-xx ← Part Number  
 ↑↑    ↑↑  
 a b    c d

Code	Contents
a	Package Type; N: SOT-23-5, H: SOT-89-5, D: HSON-6, S: HSOP-6J
b	Designation of Output Voltage ( $V_{OUT}$ ) Fixed Type: 08 to 50 Stepwise setting with 0.1V increment in the range from 0.8V to 5.0V, exceptions; 2.85V output: R1172x281x5-xx, 1.85V output: R1172x181x5-xx
c	Designation of option; A: Built-in Chip Enable Circuit, Active at "L", without auto-discharge B: Built-in Chip Enable Circuit, Active at "H", without auto-discharge D: Built-in Chip Enable Circuit, Active at "H", with auto-discharge
d	Designation of Taping Type; T1 (SOT-89-5), TR (SOT23-5, HSON-6), E2 (HSOP-6J) (Refer to Taping Specifications)

## PIN CONFIGURATION

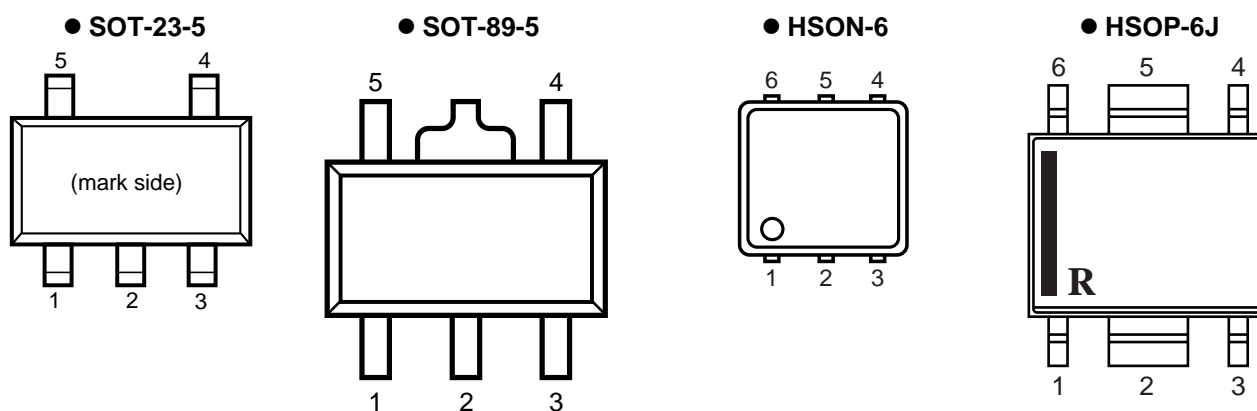

## PIN DESCRIPTION

### ●SOT-23-5 (R1172N)

Pin No	Symbol	Description
1	$V_{OUT}$	Voltage Regulator Output Pin
2	GND	Ground Pin
3	$V_{DD}$	Input Pin
4	NC	No Connection
5	$\overline{CE}$ or CE	Chip Enable Pin

### ●SOT-89-5 (R1172H)

Pin No	Symbol	Description
1	$\overline{CE}$ or CE	Chip Enable Pin
2	GND	Ground Pin
3	NC	No Connection
4	$V_{DD}$	Input Pin
5	$V_{OUT}$	Voltage Regulator Output Pin

### ●HSON-6 (R1172D)

Pin No	Symbol	Description
1	$V_{OUT}$	Voltage Regulator Output Pin
2	$V_{OUT}$	Voltage Regulator Output Pin
3	$\overline{CE}$ or CE	Chip Enable Pin
4	GND	Ground Pin
5	$V_{DD}$	Input Pin
6	$V_{DD}$	Input Pin

### ●HSOP-6J (R1172S)

Pin No	Symbol	Description
1	$V_{OUT}$	Voltage Regulator Output Pin
2	GND	Ground Pin
3	$\overline{CE}$ or CE	Chip Enable Pin
4	NC	No Connection
5	GND	Ground Pin
6	$V_{DD}$	Input Pin

\* The back side tab and tab could be GND level.  
Connect Pin1 and Pin2 as short as possible.

## ABSOLUTE MAXIMUM RATINGS

Symbol	Item	Rating	Unit
$V_{IN}$	Input Voltage	6.5	V
$V_{CE}$	Input Voltage ( $\overline{CE}$ or CE Input Pin)	-0.3 ~ 6.5	V
$V_{OUT}$	Output Voltage	-0.3 ~ $V_{IN}+0.3$	V
$I_{OUT}$	Output Current	1.4	A
$P_D$	Power Dissipation	Internally limited	
$T_{opt}$	Operating Temperature	-40 ~ 85	°C
$T_{stg}$	Storage Temperature	-55 ~ 125	°C

## Power Dissipation (SOT89-5)

Power dissipation depends on mounting conditions. The data below is an example.

### Measurement Conditions

- Mounting on board: Wind velocity=0m/s
- Board Material: Glass Epoxy Resin (Double Layers)

	High $P_D$ Land Pattern	Standard Land Pattern
Board Dimensions	30mm×30mm×1.6mm	40mm×40mm×1.6mm
Top Side Wiring Ratio	20%	Less than 10%
Back Side Wiring Ratio	100%	100%
Thermal via holes	Diameter 0.85mm×10pieces	-

### Measurement Result:

( $T_{opt}=25^\circ\text{C}$ ,  $T_{jmax}=125^\circ\text{C}$ )

	High $P_D$ Land Pattern	Standard Land Pattern
Power Dissipation	1300mW	900mW
Thermal Resistance	77°C /W	111°C /W

### Power Dissipation (SOT-89-5)

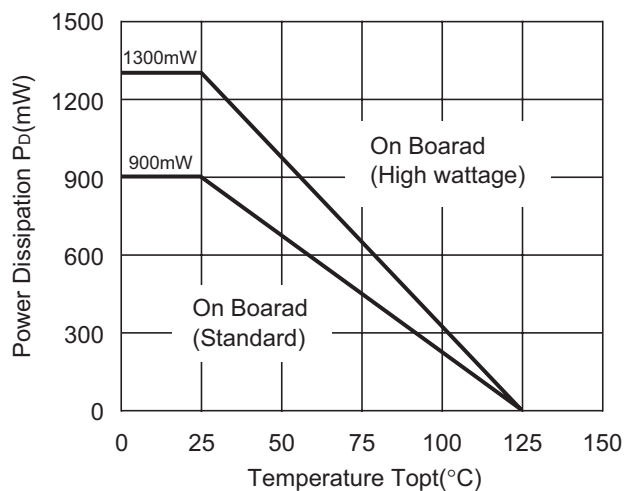

## Power Dissipation (HSON-6)

Power dissipation depends on mounting conditions. The data below is an example.

### Measurement Conditions

	Standard Land Pattern
Mounting on board	Wind velocity=0m/s
Board Material	Glass Epoxy Resin (Double Layers)
Board Dimensions	40mm×40mm×1.6mm
Wiring Ratio	50%

### Measurement Result

( $T_{opt}=25^{\circ}\text{C}$ ,  $T_{jmax}=125^{\circ}\text{C}$ )

	Standard Land Pattern
Power Dissipation	900mW
Thermal Resistance	111°C/W

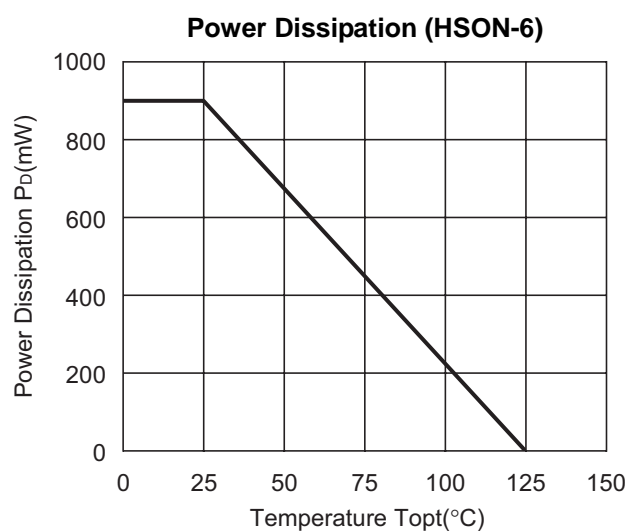

## Power Dissipation (HSOP-6J)

### Measurement Conditions

	High P <sub>D</sub> Land Pattern	Standard Land Pattern
Environment	Mounting on Board (Wind velocity=0m/s)	Mounting on Board (Wind velocity=0m/s)
Board Material	Glass Epoxy Resin (Double Layer type)	Glass Epoxy Resin (Double Layer type)
Board Dimensions	50mm×50mm×1.6mm	50mm×50mm×1.6mm
Wiring Ratio	90%	50%
Thermal via hole	Diameter: 0.5mm×24pieces	Diameter: 0.5mm×24pieces

### Measurement Result

(T<sub>opt</sub>=25°C, T<sub>jmax</sub>=125°C)

	High P <sub>D</sub> Land Pattern	Standard Land Pattern
Power Dissipation	2000mW	1700mW
Thermal Resistance	50°C /W	59°C /W

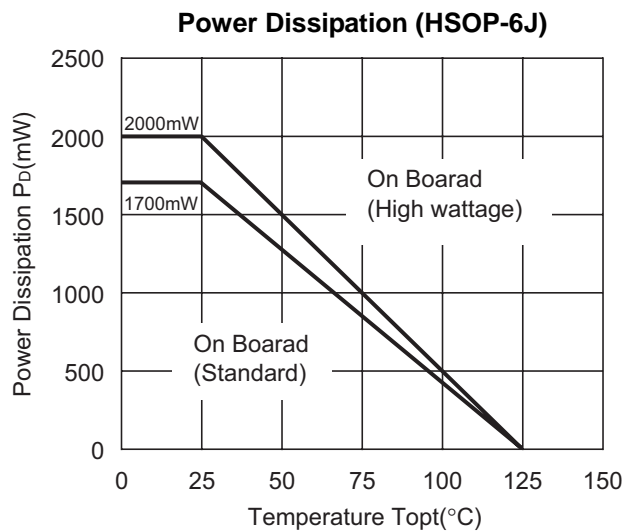

## ELECTRICAL CHARACTERISTICS

### • R1172xxxxA

$T_{opt}=25^{\circ}\text{C}$

Symbol	Item	Conditions	Min.	Typ.	Max.	Unit
$V_{IN}$	Input Voltage		1.4		6.0	V
$I_{SS}$	Supply Current	$V_{IN}-V_{OUT}=1.0\text{V}$ , $V_{CE}=0\text{V}$		60	100	$\mu\text{A}$
$I_{standby}$	Standby Current	$V_{IN}=6.0\text{V}$ , $V_{CE}=V_{IN}$		0.1	1.0	$\mu\text{A}$
$V_{OUT}$	Output voltage	$V_{IN}-V_{OUT}=1.0\text{V}$ $I_{OUT}=100\text{mA}$ $V_{OUT} > 1.5\text{V}$	$\times 0.98$		$\times 1.02$	V
		$V_{OUT} \leq 1.5\text{V}$	-30		+30	mV
$I_{OUT1}$	Output Current	$V_{IN}-V_{OUT}=1.0\text{V}$	1			A
$\frac{\Delta V_{OUT}}{\Delta I_{OUT}}$	Load regulation	$V_{IN}-V_{OUT}=0.3\text{V}$ $1\text{mA} \leq I_{OUT} \leq 300\text{mA}$ If $V_{OUT} \leq 1.1\text{V}$ , then $V_{IN}=1.4\text{V}$	-15	15	30	mV
		$V_{IN}-V_{OUT}=0.3\text{V}$ $1\text{mA} \leq I_{OUT} \leq 1\text{A}$ If $V_{OUT} \leq 1.1\text{V}$ , then $V_{IN}=1.7\text{V}$		50		
$V_{DIF}$	Dropout Voltage	Refer to Dropout Voltage Characteristics Table by Output Voltage				
$\frac{\Delta V_{OUT}}{\Delta V_{IN}}$	Line regulation	$I_{OUT}=100\text{mA}$ $V_{OUT}+0.5\text{V} \leq V_{IN} \leq 6.0\text{V}$ If $V_{OUT} \leq 0.9\text{V}$ , $1.4\text{V} \leq V_{IN} \leq 6.0\text{V}$		0.05	0.20	%/V
RR	Ripple Rejection	$f=1\text{kHz}$ ( $V_{OUT} \leq 4.0\text{V}$ ) $f=1\text{kHz}$ ( $V_{OUT} > 4.0\text{V}$ ) Ripple 0.5Vp-p, $I_{OUT}=100\text{mA}$ $V_{IN}-V_{OUT}=1.0\text{V}$ If $V_{OUT} \leq 1.2\text{V}$ , $V_{IN}-V_{OUT}=1.5\text{V}$		70 60		dB
$\frac{\Delta V_{OUT}}{\Delta T_{opt}}$	Output Voltage Temperature Coefficient	$I_{OUT}=100\text{mA}$ $-40^{\circ}\text{C} \leq T_{opt} \leq 85^{\circ}\text{C}$		$\pm 100$		ppm/ $^{\circ}\text{C}$
$I_{LIM}$	Short Current Limit	$V_{OUT}=0\text{V}$		250		mA
$R_{PU}$	Pull-up resistance for $\overline{\text{CE}}$ pin		1.9	5.0	15.0	$\text{M}\Omega$
$V_{CEH}$	$\overline{\text{CE}}$ Input Voltage "H"		1.0		6.0	V
$V_{CEL}$	$\overline{\text{CE}}$ Input Voltage "L"		0.0		0.4	V
$T_{TSD}$	Thermal Shutdown Detector Threshold Temperature	Junction Temperature		150		$^{\circ}\text{C}$
$T_{TSR}$	Thermal Shutdown Released Temperature	Junction Temperature		120		$^{\circ}\text{C}$
en	Output Noise	BW=10Hz to 100kHz		30		$\mu\text{Vrms}$

**R1172x**
**• R1172xxxxB/D**
 $T_{opt}=25^{\circ}\text{C}$ 

Symbol	Item	Conditions	Min.	Typ.	Max.	Unit
$V_{IN}$	Input Voltage		1.4		6.0	V
$I_{SS}$	Supply Current	$V_{IN}-V_{OUT}=1.0\text{V}$ , $V_{CE}=V_{IN}$		60	100	$\mu\text{A}$
Istandby	Standby Current	$V_{IN}=6.0\text{V}$ , $V_{CE}=\text{GND}$		0.1	1.0	$\mu\text{A}$
$V_{OUT}$	Output voltage	$V_{IN}-V_{OUT}=1.0\text{V}$ $I_{OUT}=100\text{mA}$	$V_{OUT} \geq 1.5\text{V}$	$\times 0.98$	$\times 1.02$	V
			$V_{OUT} \leq 1.5\text{V}$	-30	+30	mV
$I_{OUT}$	Output Current	$V_{IN}-V_{OUT}=1.0\text{V}$	1			A
$\Delta V_{OUT}/\Delta I_{OUT}$	Load regulation	$V_{IN}-V_{OUT}=0.3\text{V}$ $1\text{mA} \leq I_{OUT} \leq 300\text{mA}$ If $V_{OUT} \leq 1.1\text{V}$ , then $V_{IN}=1.4\text{V}$	-15	15	30	mV
		$V_{IN}-V_{OUT}=0.3\text{V}$ $1\text{mA} \leq I_{OUT} \leq 1\text{A}$ If $V_{OUT} \leq 1.1\text{V}$ , then $V_{IN}=1.7\text{V}$		50		
$V_{DIF}$	Dropout Voltage	Refer to Dropout Voltage Characteristics Table by Output Voltage				
$\Delta V_{OUT}/\Delta V_{IN}$	Line regulation	$I_{OUT}=100\text{mA}$ $V_{OUT}+0.5\text{V} \leq V_{IN} \leq 6.0\text{V}$ If $V_{OUT} \leq 0.9\text{V}$ , $1.4\text{V} \leq V_{IN} \leq 6.0\text{V}$		0.05	0.20	%/V
RR	Ripple Rejection	$f=1\text{kHz}$ ( $V_{OUT} \leq 4.0\text{V}$ ) $f=1\text{kHz}$ ( $V_{OUT} > 4.0\text{V}$ ) Ripple $0.5\text{Vp-p}$ , $I_{OUT}=100\text{mA}$ $V_{IN}-V_{OUT}=1.0\text{V}$ If $V_{OUT} \leq 1.2\text{V}$ , $V_{IN}-V_{OUT}=1.5\text{V}$ , $I_{OUT}=100\text{mA}$		70 60		dB
$\Delta V_{OUT}/\Delta T_{opt}$	Output Voltage Temperature Coefficient	$I_{OUT}=100\text{mA}$ $-40^{\circ}\text{C} \leq T_{opt} \leq 85^{\circ}\text{C}$		$\pm 100$		ppm/ $^{\circ}\text{C}$
$I_{LIM}$	Short Current Limit	$V_{OUT}=0\text{V}$		250		mA
$R_{PD}$	Pull-down resistance for CE pin		1.9	5.0	15.0	$\text{M}\Omega$
$V_{CEH}$	CE Input Voltage "H"		1.0		6.0	V
$V_{CEL}$	CE Input Voltage "L"		0.0		0.4	V
$T_{TSD}$	Thermal Shutdown Detector Threshold Temperature	Junction Temperature		150		$^{\circ}\text{C}$
$T_{TSR}$	Thermal Shutdown Released Temperature	Junction Temperature		120		$^{\circ}\text{C}$
en	Output Noise	$\text{BW}=10\text{Hz}$ to $100\text{kHz}$		30		$\mu\text{Vrms}$

### • Dropout Voltage by Output Voltage

(T<sub>opt</sub>=25°C)

Output Voltage V <sub>OUT</sub> (V)	Dropout Voltage (V)		
	I <sub>OUT</sub> =300mA		I <sub>OUT</sub> =1A
	Typ.	Max.	Typ.
0.8 ≤ V <sub>OUT</sub> < 0.9	0.33	0.57	0.72
0.9 ≤ V <sub>OUT</sub> < 1.0	0.22	0.47	0.64
1.0 ≤ V <sub>OUT</sub> < 1.5	0.18	0.32	0.56
1.5 ≤ V <sub>OUT</sub> < 2.6	0.10	0.15	0.32
2.6 ≤ V <sub>OUT</sub>	0.05	0.10	0.18

## Technical Notes on External Components and Typical Application

### Phase Compensation

In these ICs, phase compensation is made with the output capacitor for securing stable operation even if the load current is varied. For this purpose, use as much as 10μF Capacitor as C2 Recommendation value is as follows:

Output Voltage	C2 recommendation value	Components Recommendation
V <sub>OUT</sub> <1.0V	Tantalum 4.7μF or more	
1.0 ≤ V <sub>OUT</sub> ≤ 3.3V	Ceramic 4.7μF or more	Kyocera 4.7μF (1608) Part Number : CM105X5R475M06AB Murata 4.7μF (1608) Part Number : GRM188R60J475KE19B Murata 10μF (1608) Part Number : GRM188B30G106ME46B
3.3V<V <sub>OUT</sub>	Ceramic 4.7μF or more	Kyocera 4.7μF (thin 2012) Part Number : CT21X5R475M06AB Murata 10μF (2012) Part Number : GRM21BB30J106K

If you use a tantalum type capacitor and ESR value of the capacitor is large, output might be unstable. Evaluate your circuit with considering frequency characteristics.

Depending on the capacitor size, manufacturer, and part number, the bias characteristics and temperature characteristics are different. Evaluate the circuit with actual using capacitors.

### Mounting on PCB

Make V<sub>DD</sub> and GND lines sufficient. If their impedance is high, a current flows, the noise picked up or unstable operation may result. Further use a 4.7μF or more value as C1 between V<sub>DD</sub> pin and GND pin as close as possible.

Set an Output capacitor between V<sub>OUT</sub> pin and GND pin for phase compensation as close as possible.  
(Refer to the example of typical application)

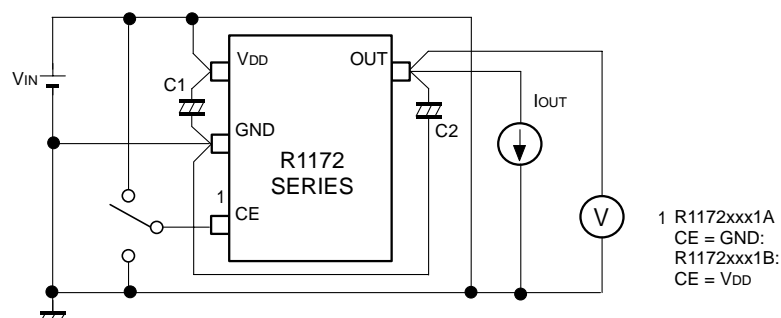

Example of the typical application of R1172x

## TYPICAL CHARACTERISTICS

### 1) Output Voltage vs. Output Current (Topt=25°C)

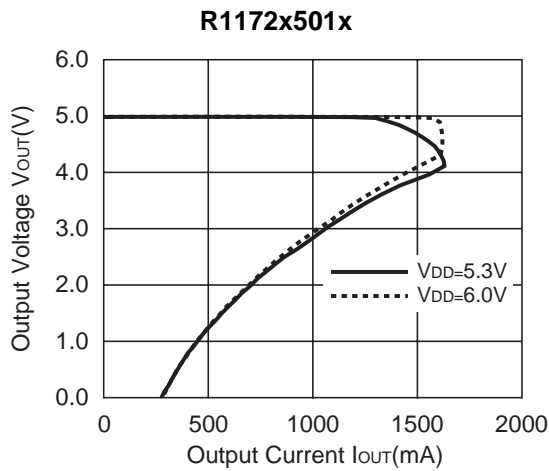
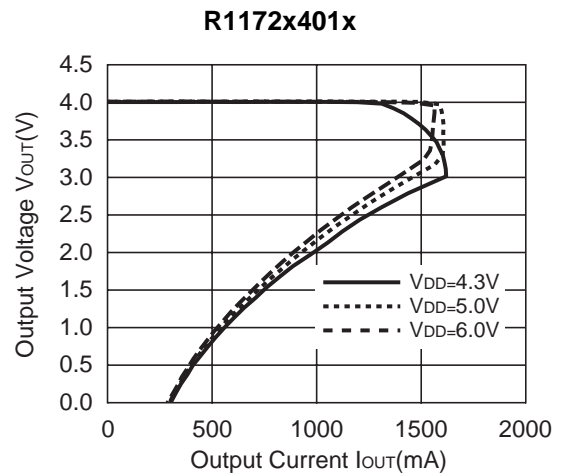
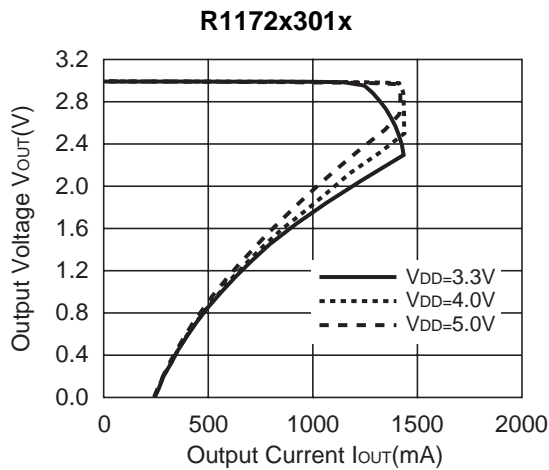
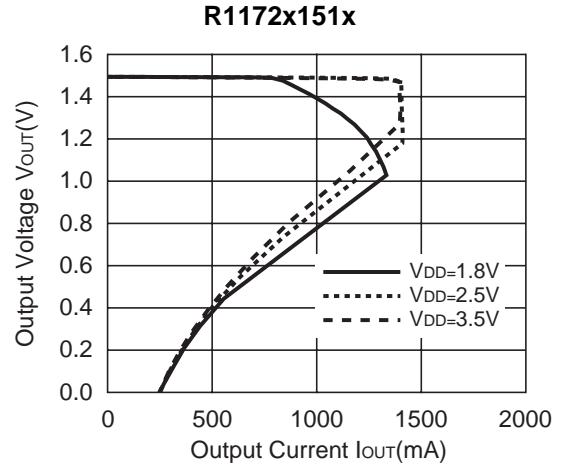
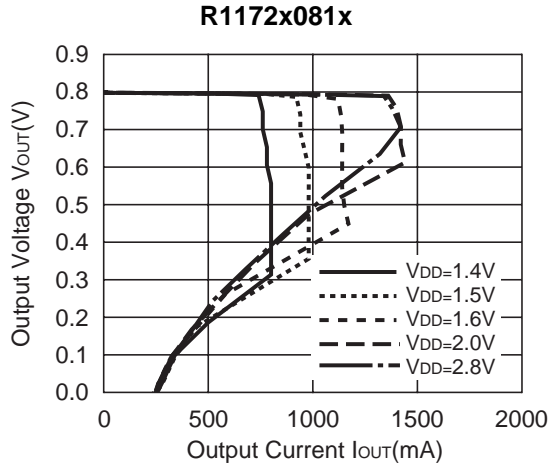

2) Output Voltage vs. Input Voltage (T<sub>opt</sub>=25°C)

R1172x081x

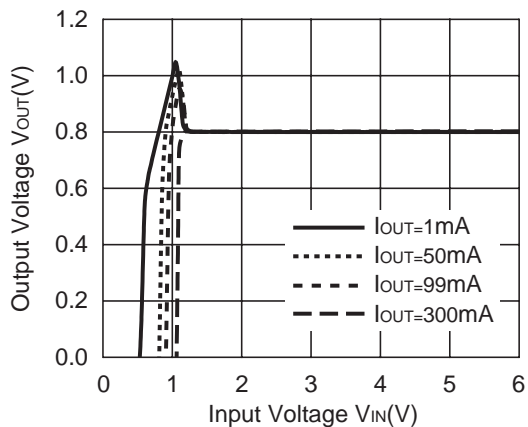

R1172x151x

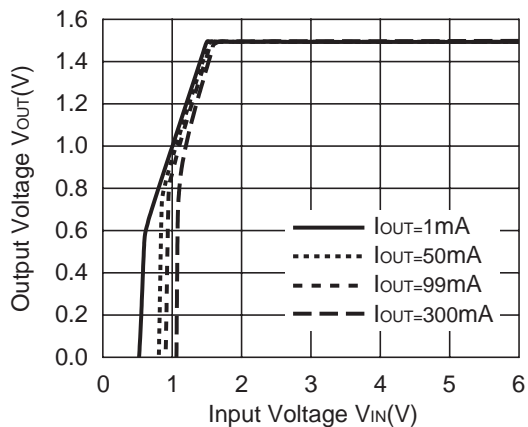

R1172x301x

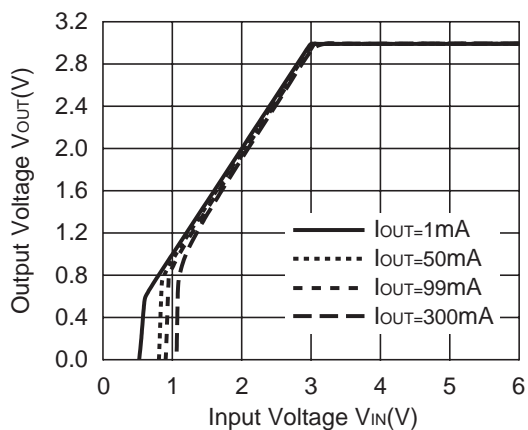

R1172x401x

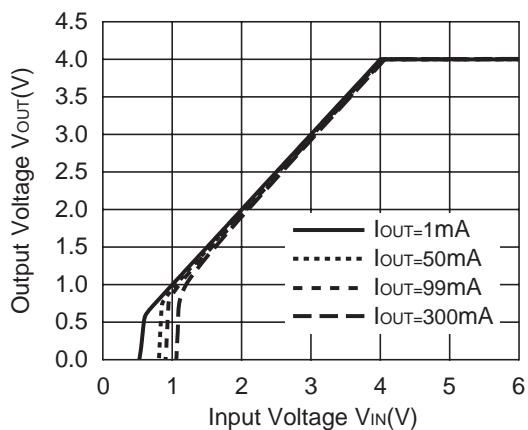

R1172x501x

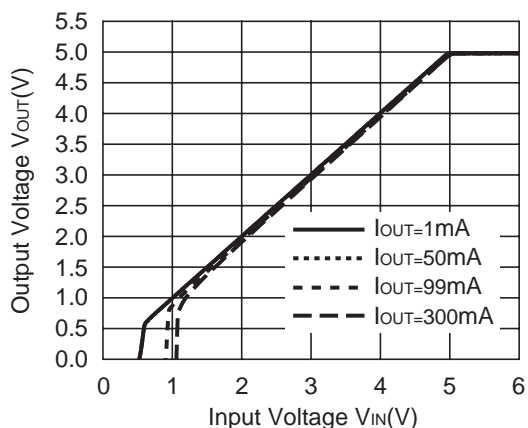

3) Dropout Voltage vs. Output Current (Topt=25°C)

R1172x081x

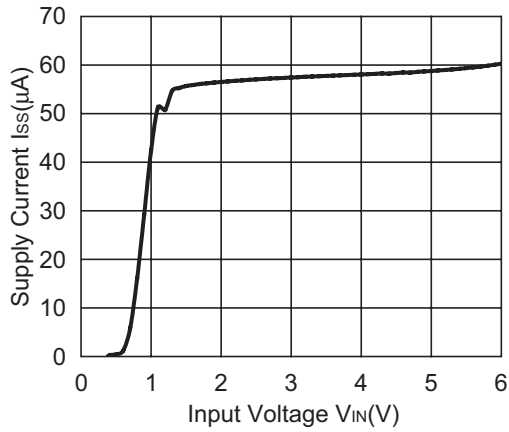

R1172x151x

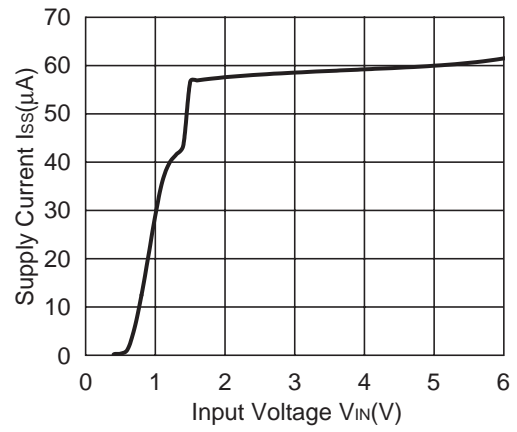

R1172x301x

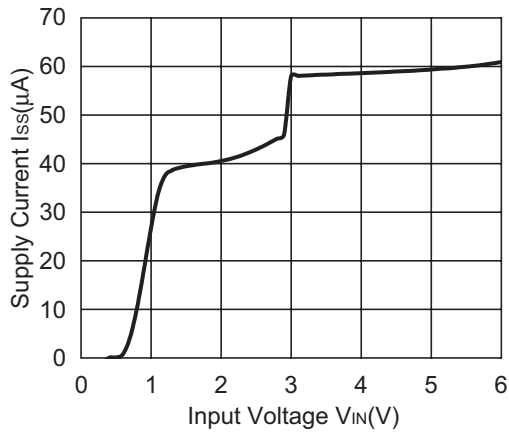

R1172x401x

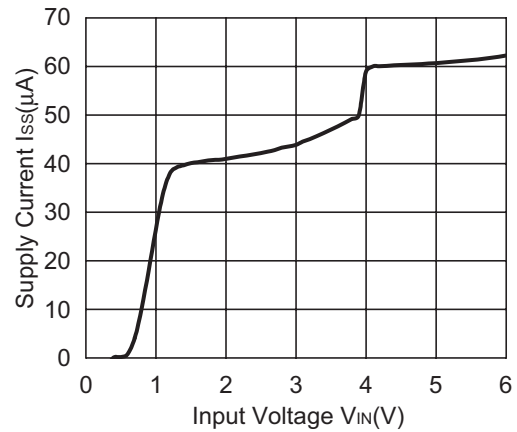

R1172x501x

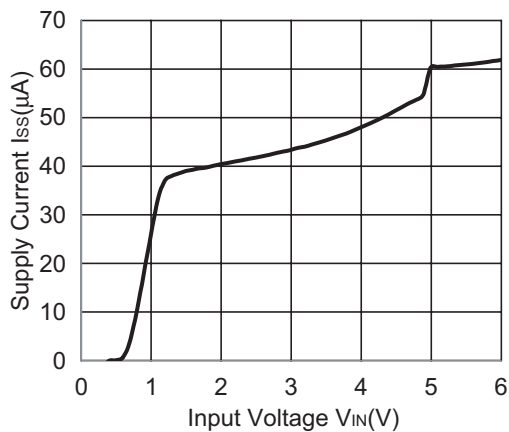

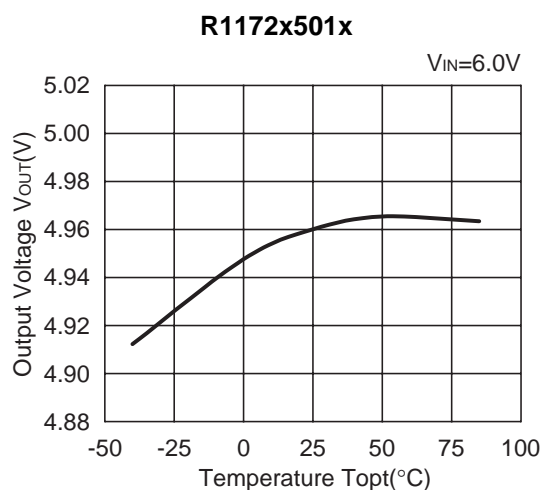
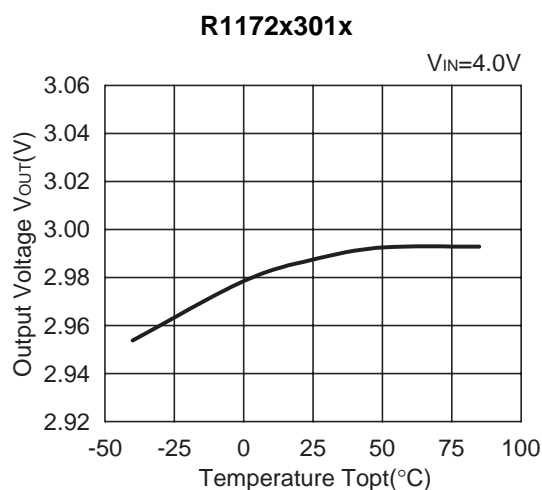
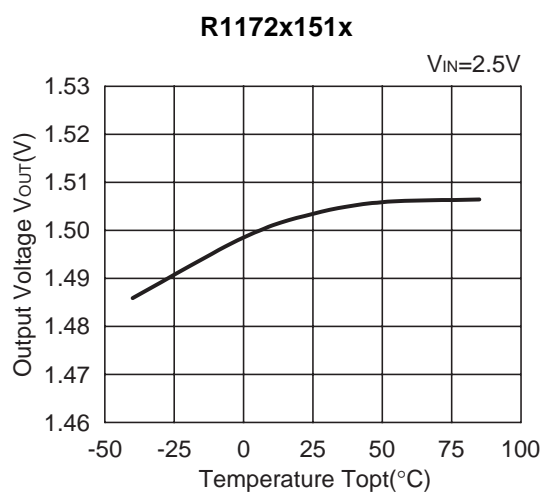
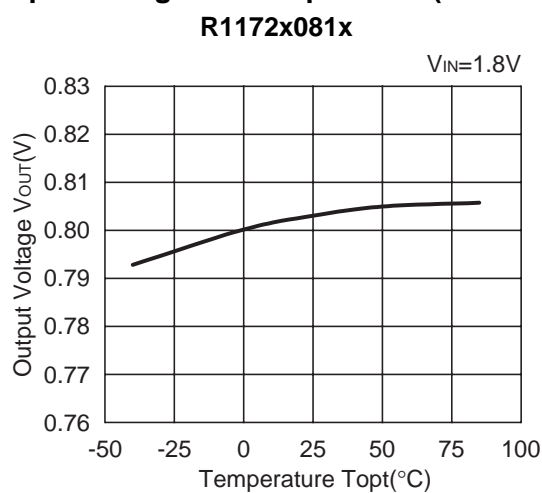
4) Output Voltage vs. Temperature ( $I_{OUT}=100mA$ )

## 5) Supply Current vs. Temperature

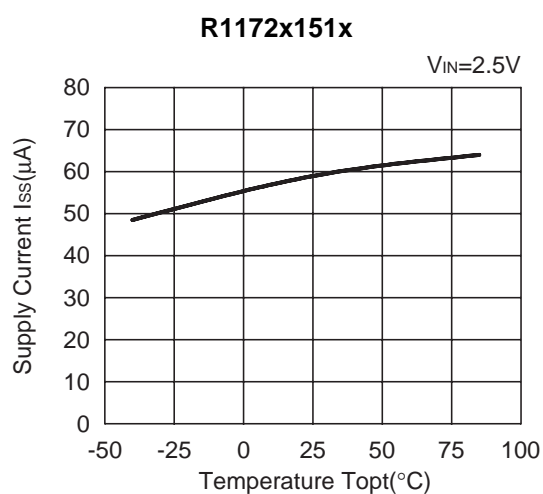
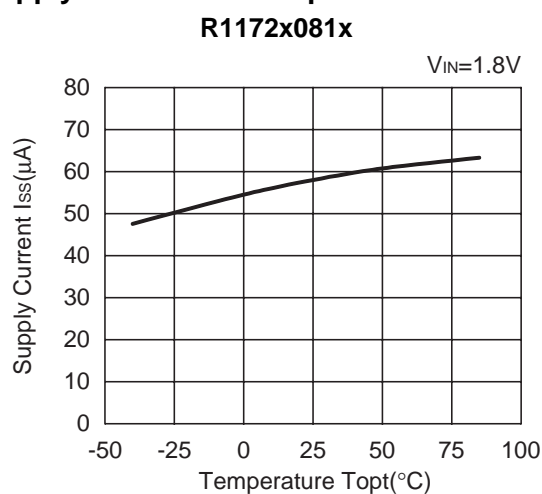

R1172x301x

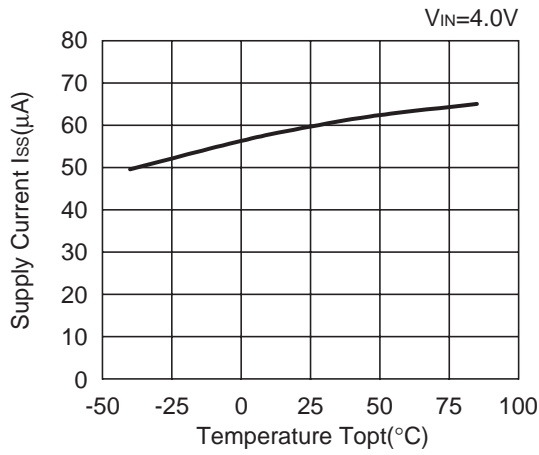

R1172x501x

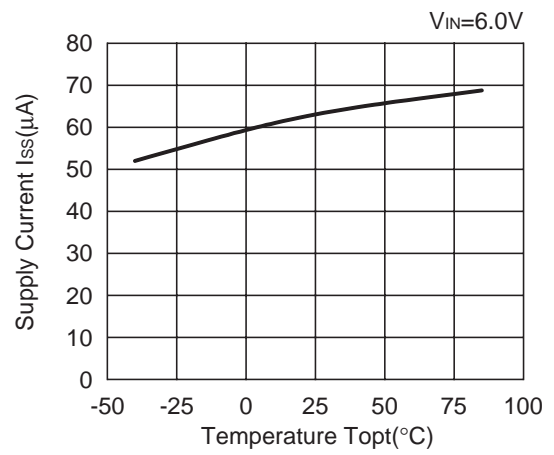

6) Dropout Voltage vs. Output Current

R1172x081x

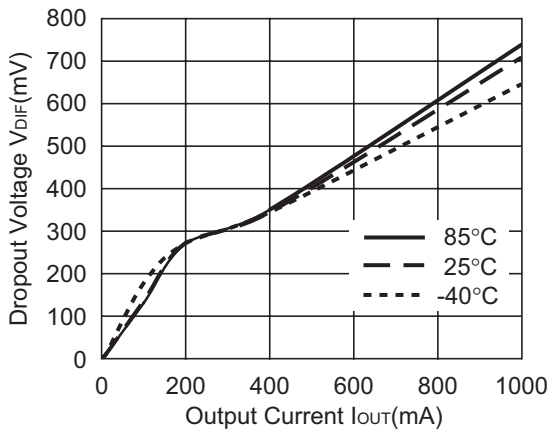

R1172x091x

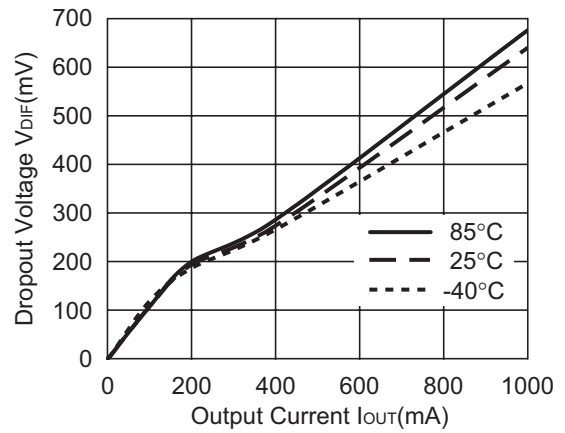

R1172x101x

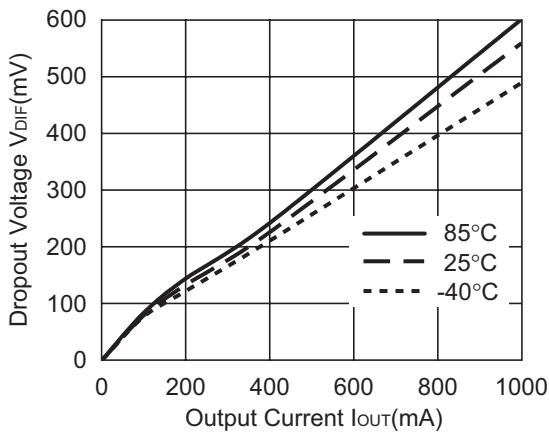

R1172x151x

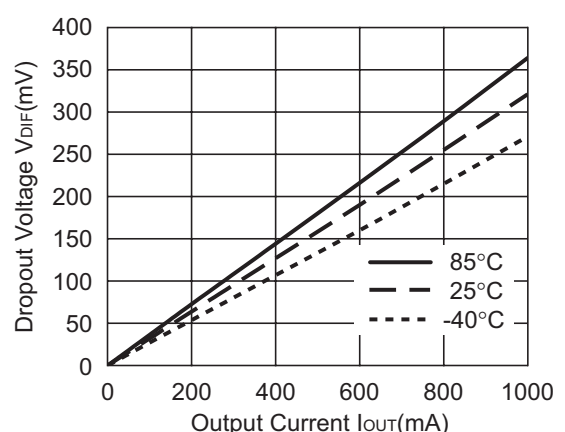

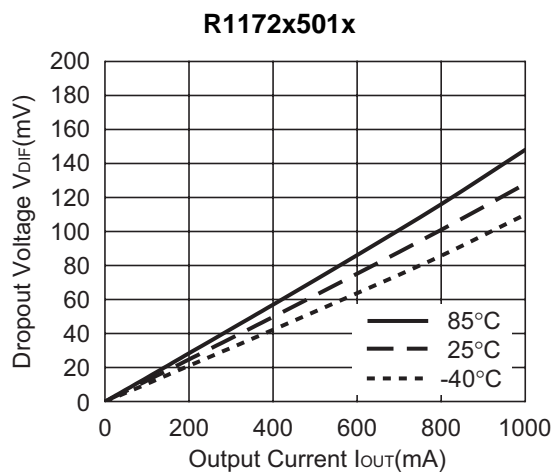
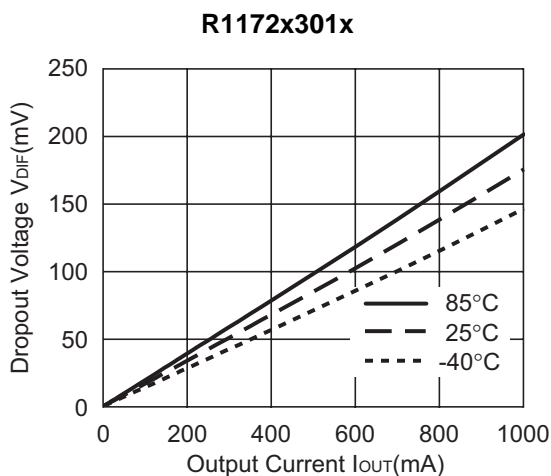

**7) Dropout Voltage vs. Set Output Voltage**

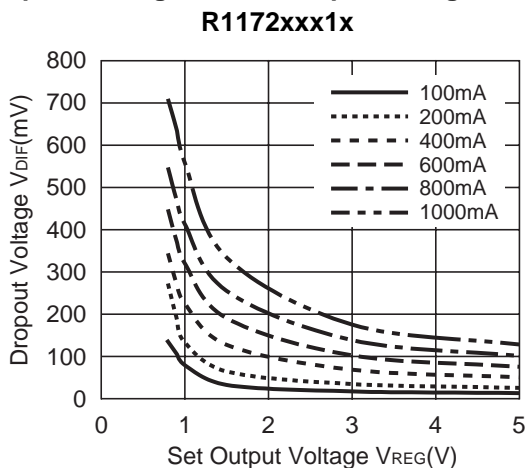

**8) 0.8V Output type, Operating Input Voltage Range**

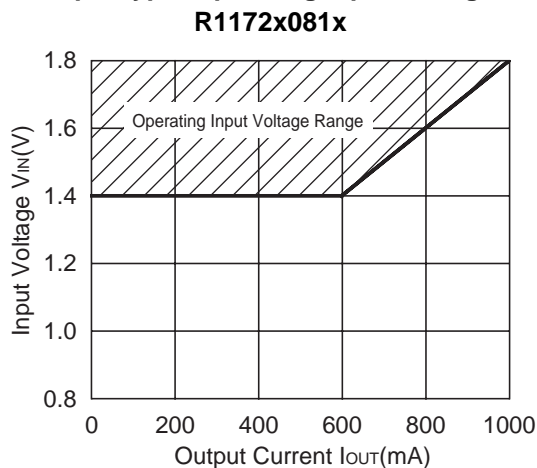

**9) Ripple Rejection vs. Input Bias**

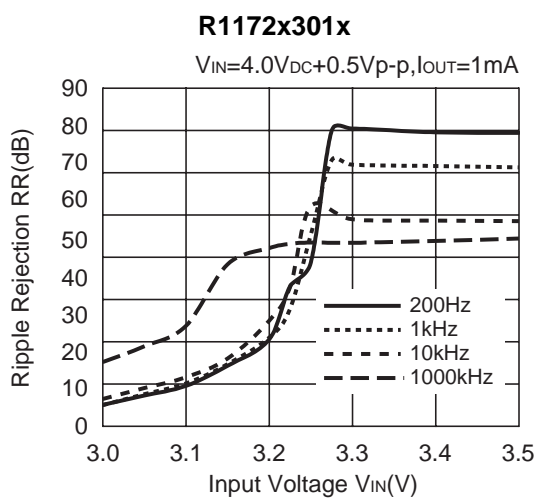
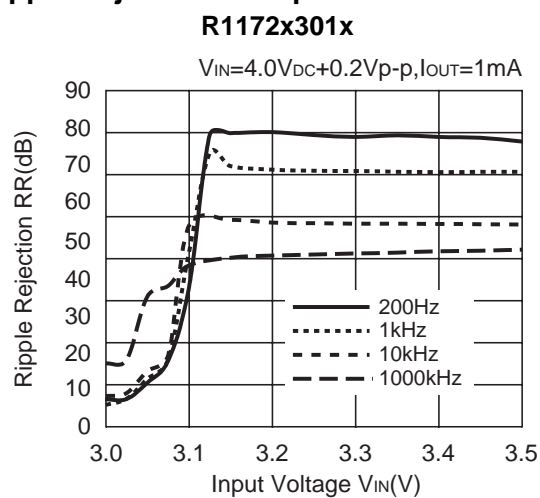

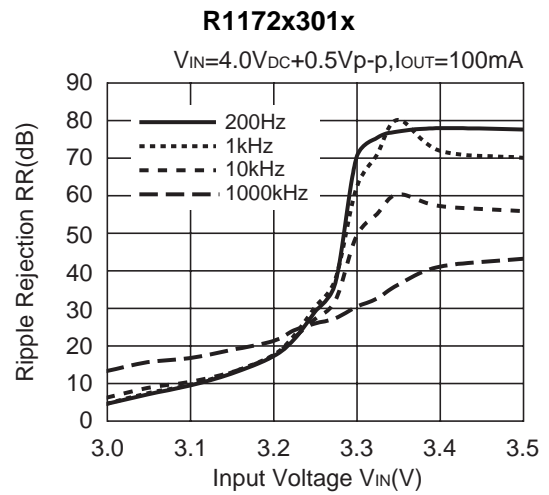
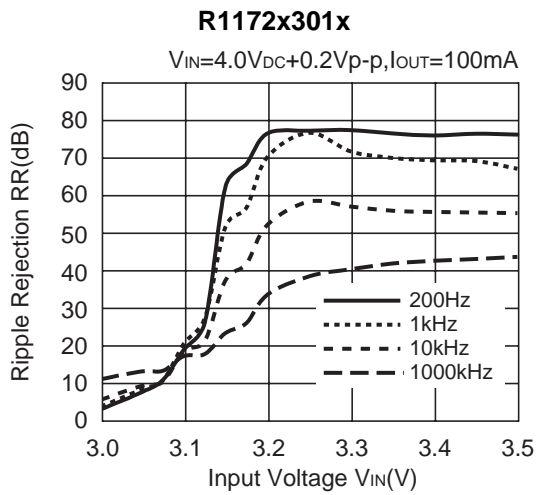
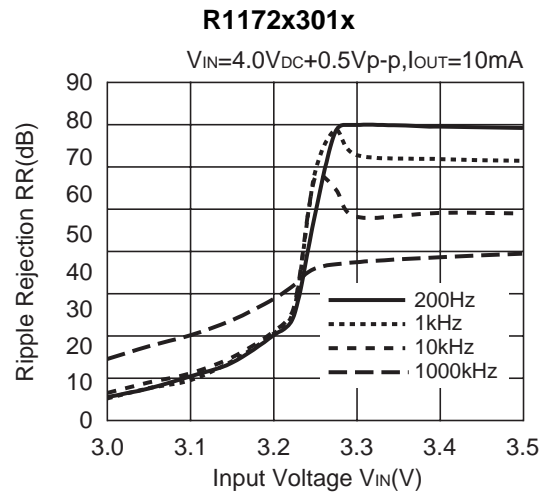
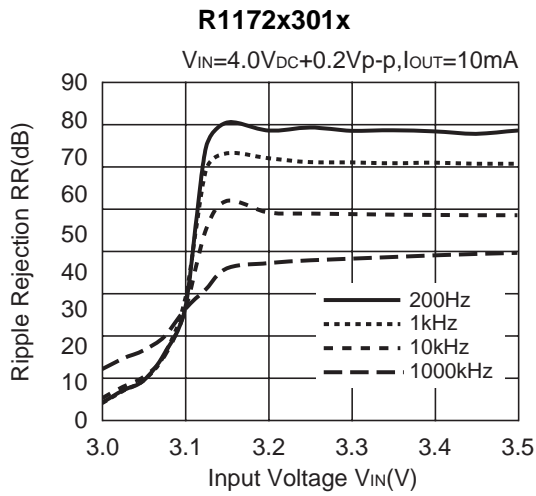

**10) Ripple Rejection vs. Frequency**

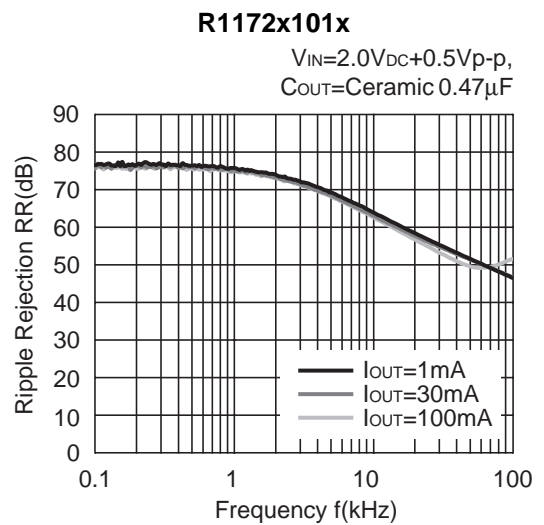
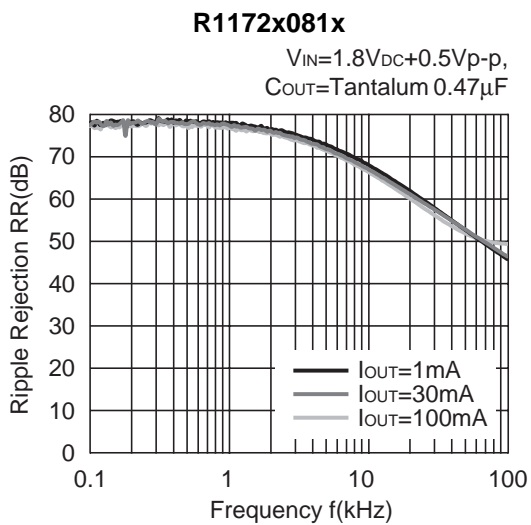

**R1172x301x**

$V_{IN}=4.0V_{DC}+0.5V_{p-p}$ ,  
 $C_{OUT}=\text{Ceramic } 0.47\mu F$

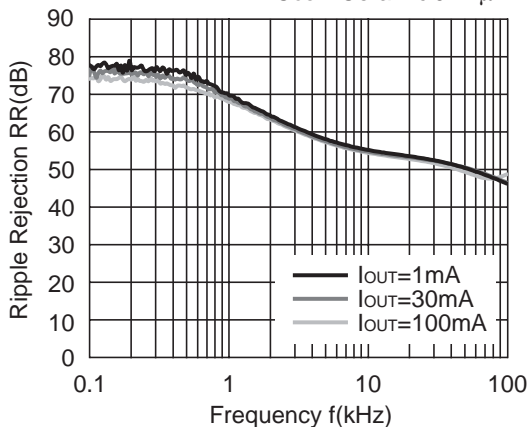

**R1172x401x**

$V_{IN}=5.0V_{DC}+0.5V_{p-p}$ ,  
 $C_{OUT}=\text{Ceramic } 0.47\mu F$

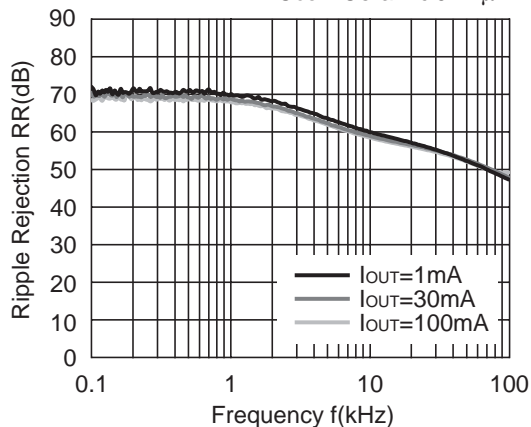

**R1172x451x**

$V_{IN}=5.5V_{DC}+0.5V_{p-p}$ ,  
 $C_{OUT}=\text{Ceramic } 0.47\mu F$

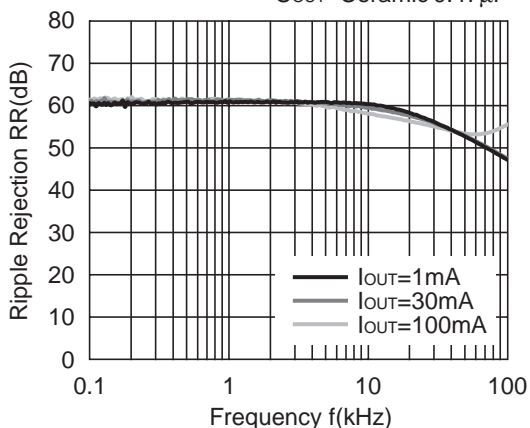

**R1172x501x**

$V_{IN}=6.0V_{DC}+0.5V_{p-p}$ ,  
 $C_{OUT}=\text{Ceramic } 0.47\mu F$

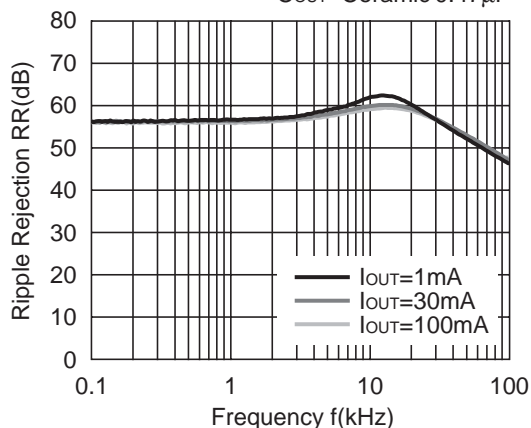

**11) Line Transient Response ( $T_r = T_f = 5\mu s$ ,  $I_{OUT}=100mA$ )**

**R1172x081x**

$C_{OUT}=\text{Tantalum } 4.7\mu F$

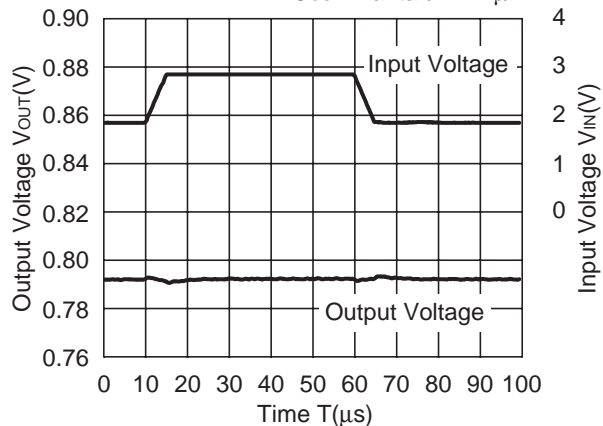

**R1172x101x**

$C_{OUT}=\text{Ceramic } 4.7\mu F$

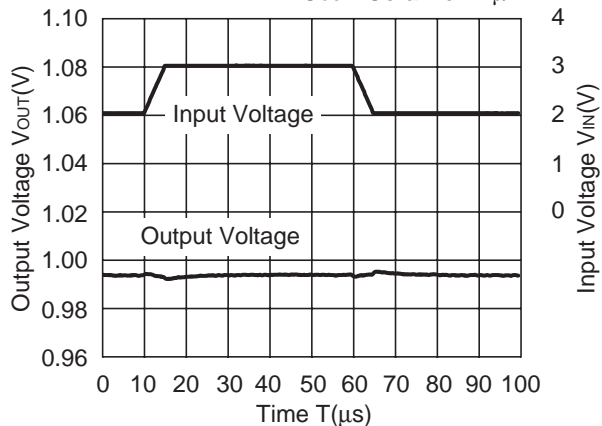

**R1172x301x**

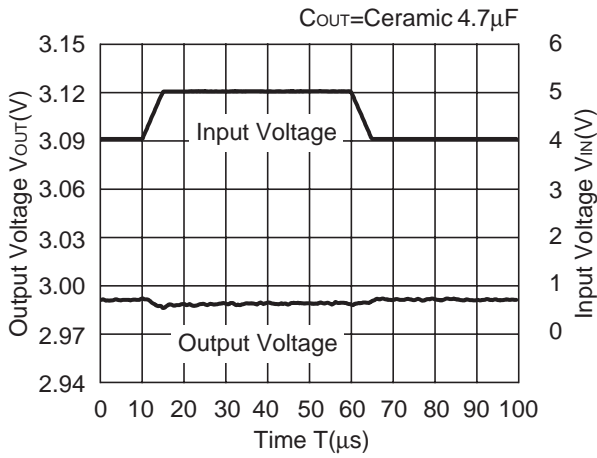

**R1172x501x**

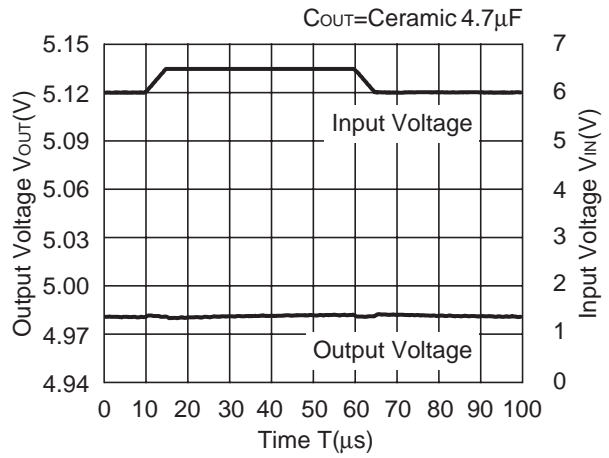

**12) Load Transient Response ( $T_r = T_f = 500\text{ns}$ )**

**R1172x081x**

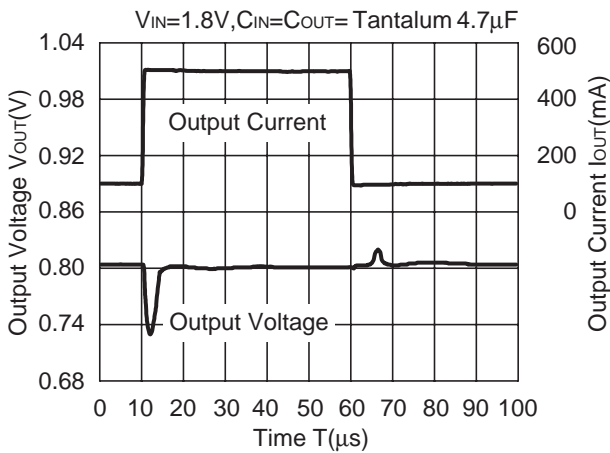

**R1172x081x**

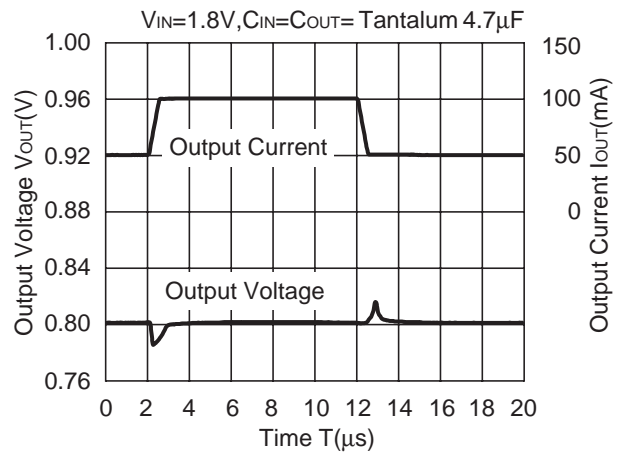

**R1172x081x**

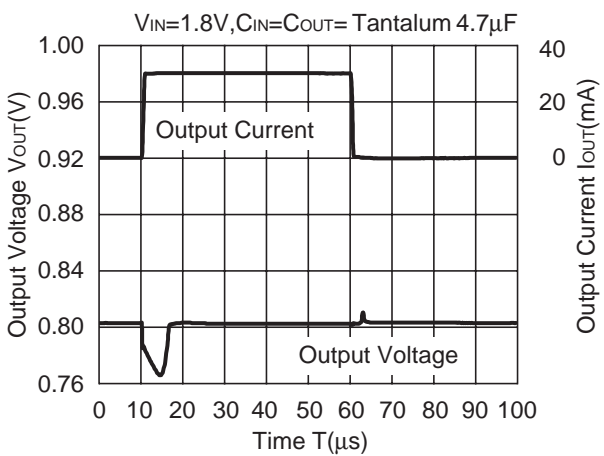

**R1172x081x**

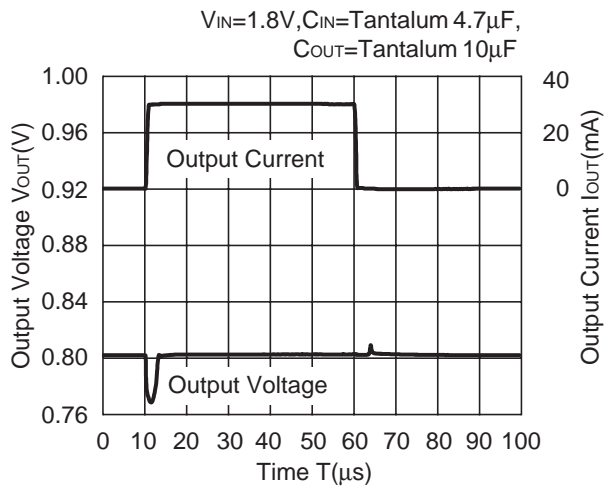

**R1172x101x**

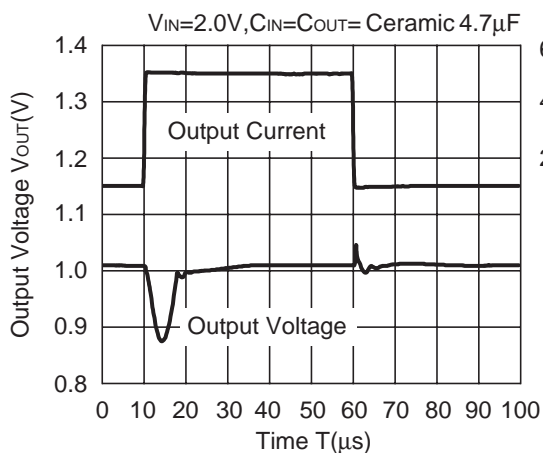

**R1172x101x**

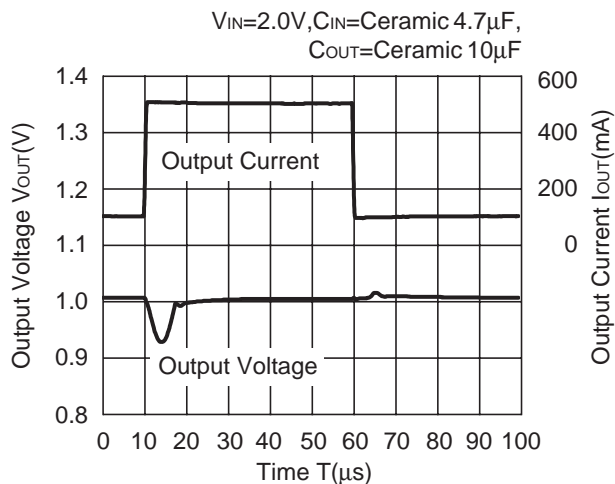

**R1172x101x**

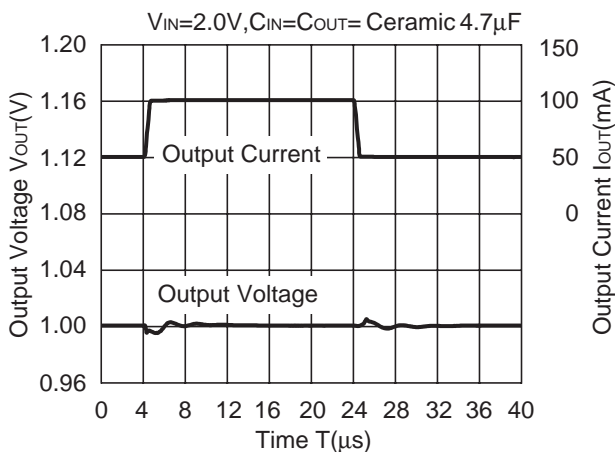

**R1172x101x**

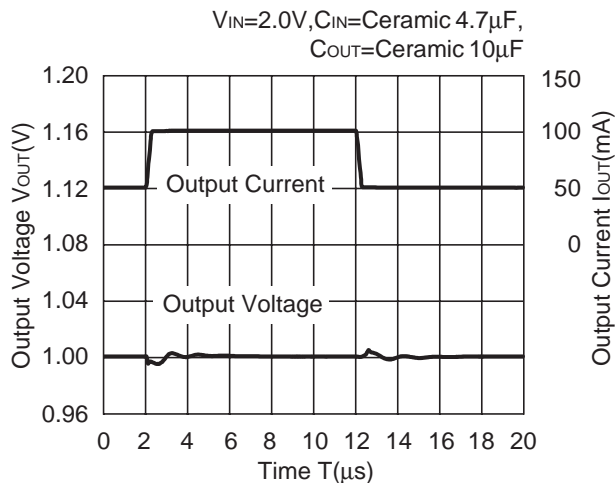

**R1172x101x**

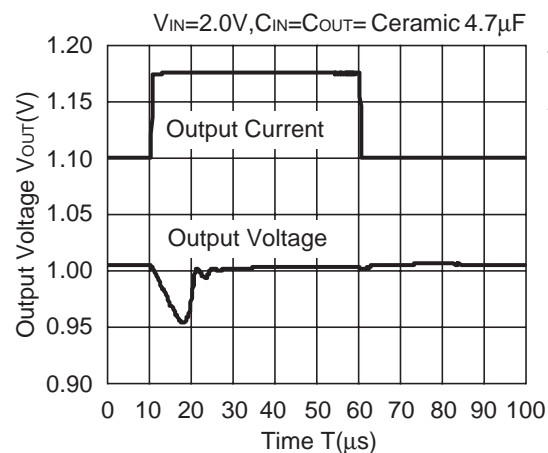

**R1172x101x**

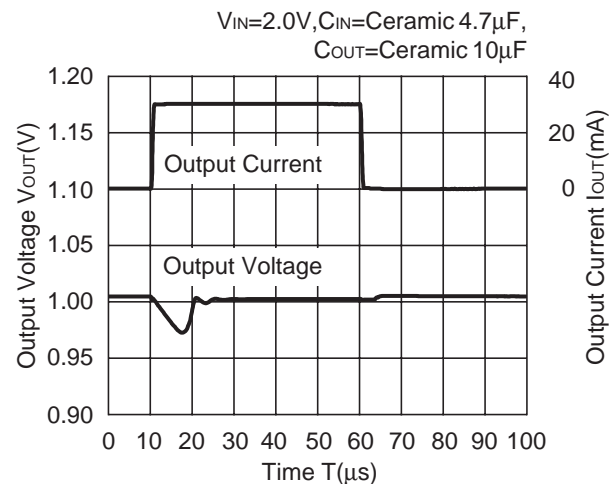

**R1172x301x**

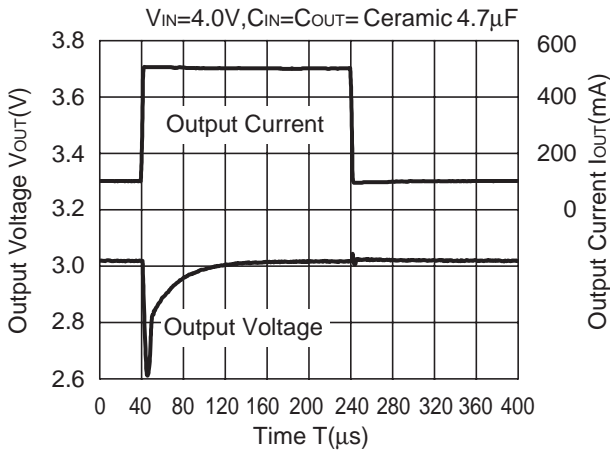

**R1172x301x**

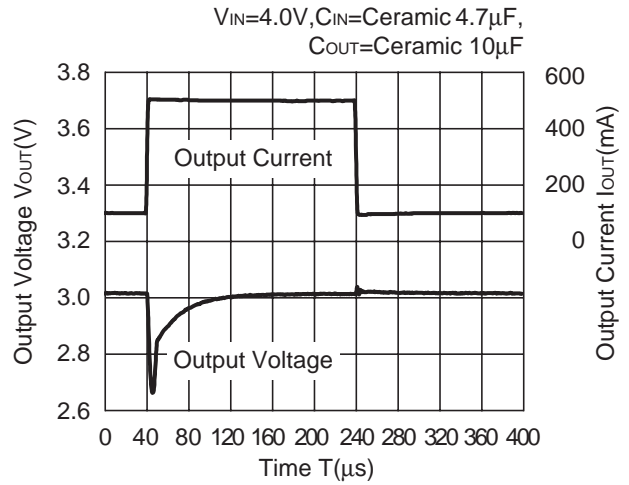

**R1172x301x**

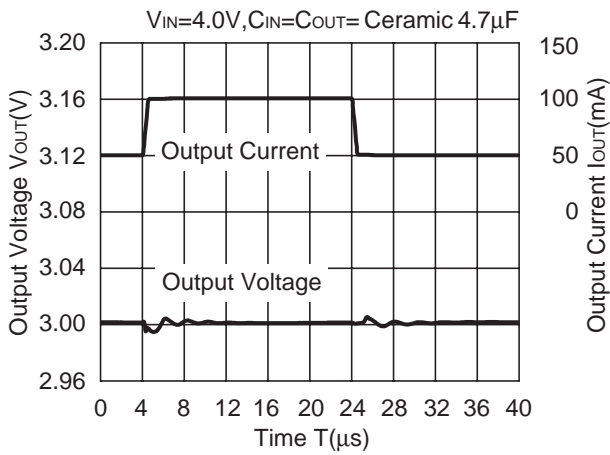

**R1172x301x**

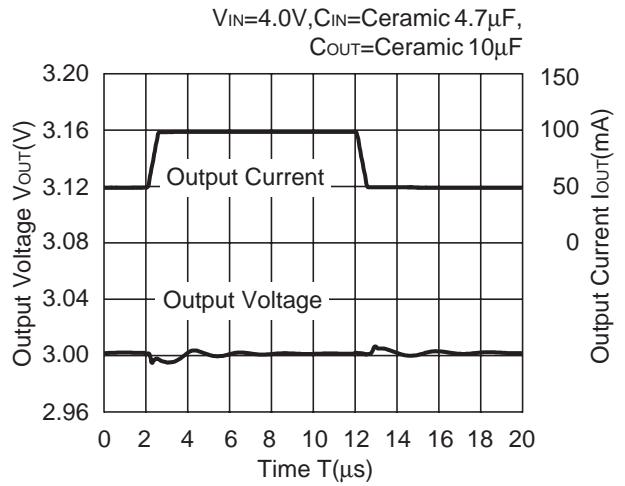

**R1172x301x**

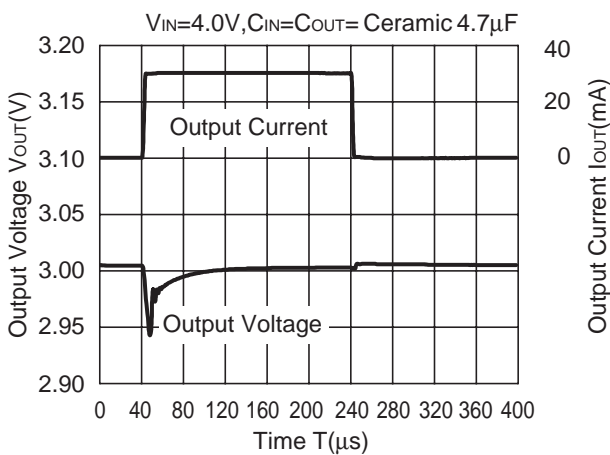

**R1172x301x**

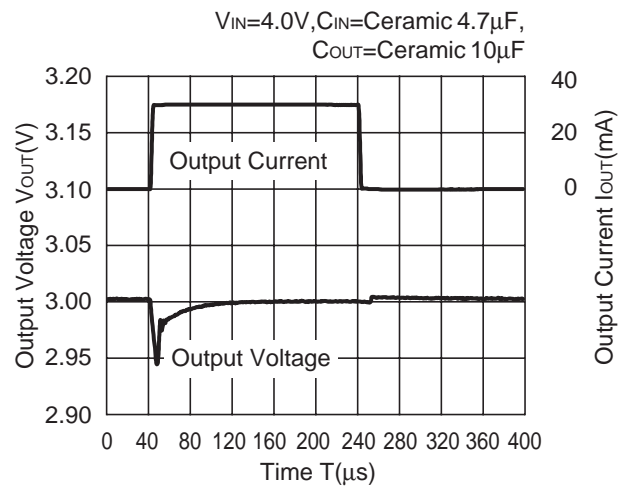

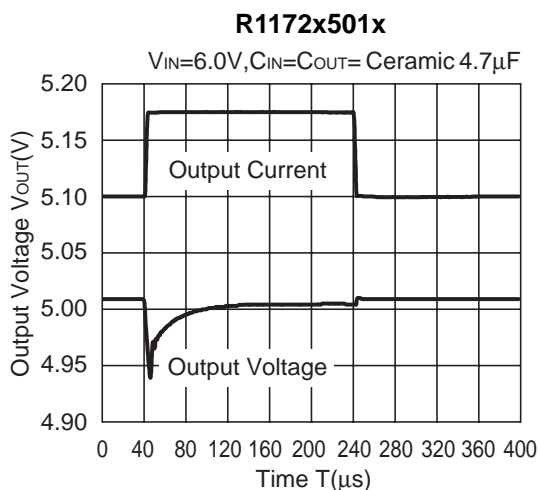
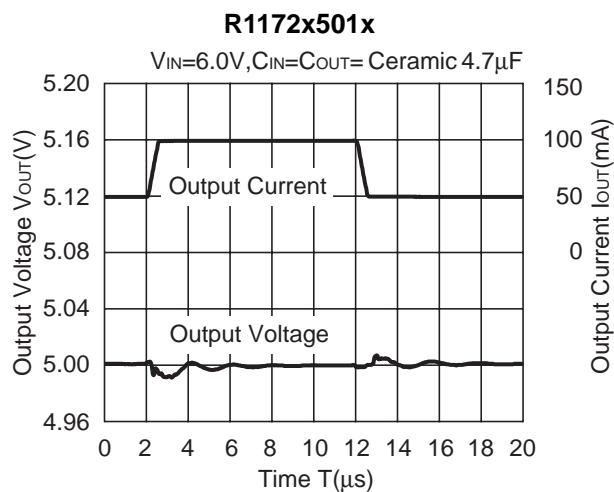
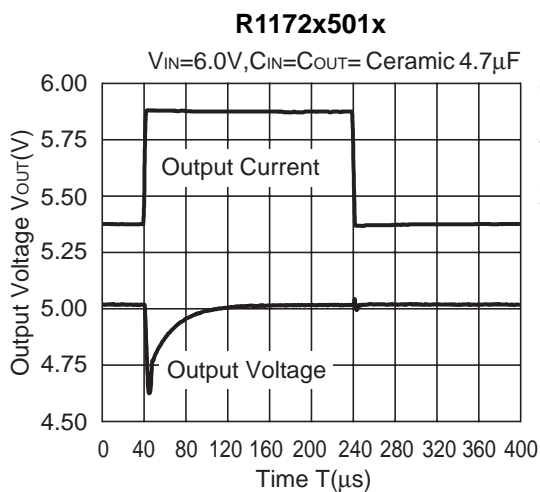

**13) Turn-on speed with CE pin control**

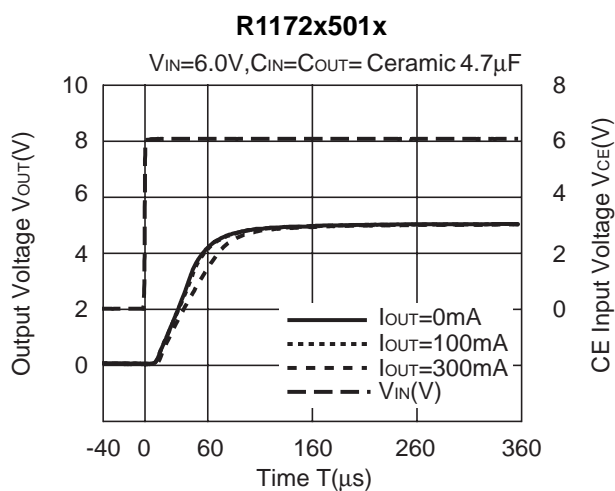
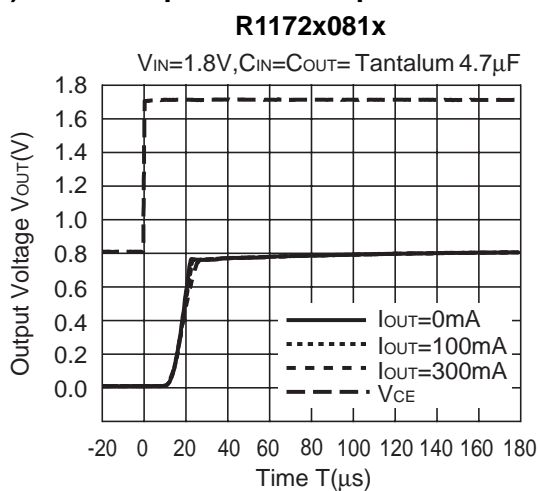

14) Turn-off speed with CE pin control

R1172x081D

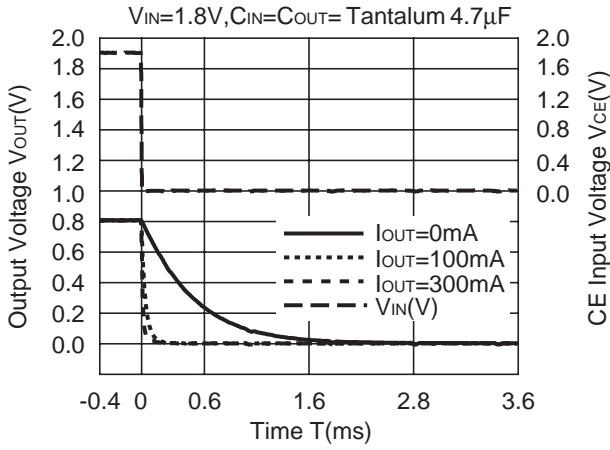

R1172x501D

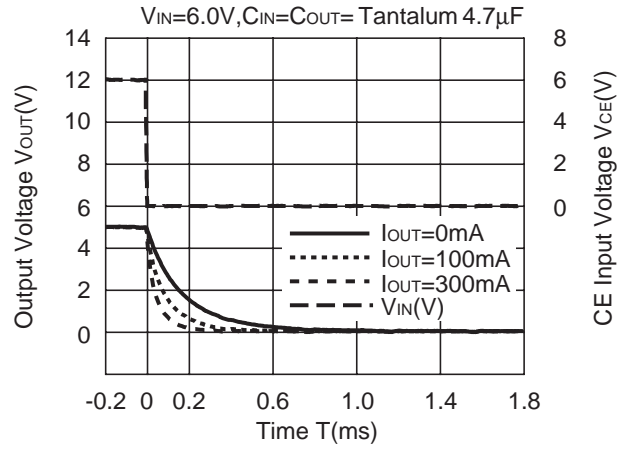

15) Inrush Current ( $I_{OUT}=100mA, C_{IN}=\text{none}$ )

R1172x081x

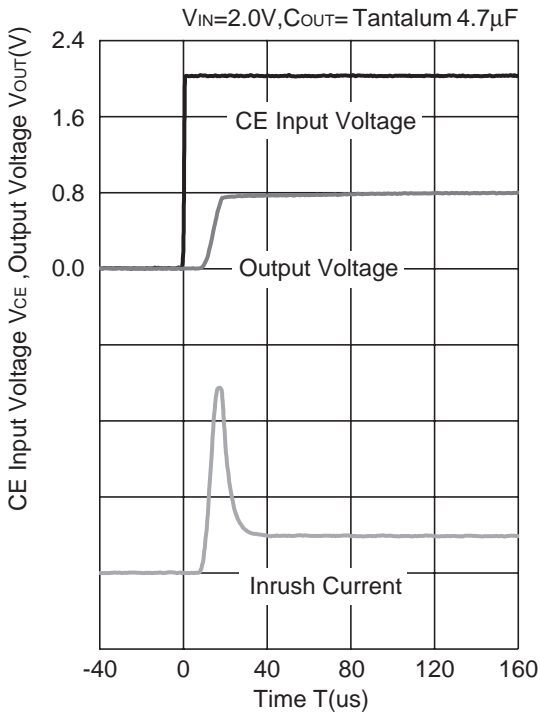

R1172x081x

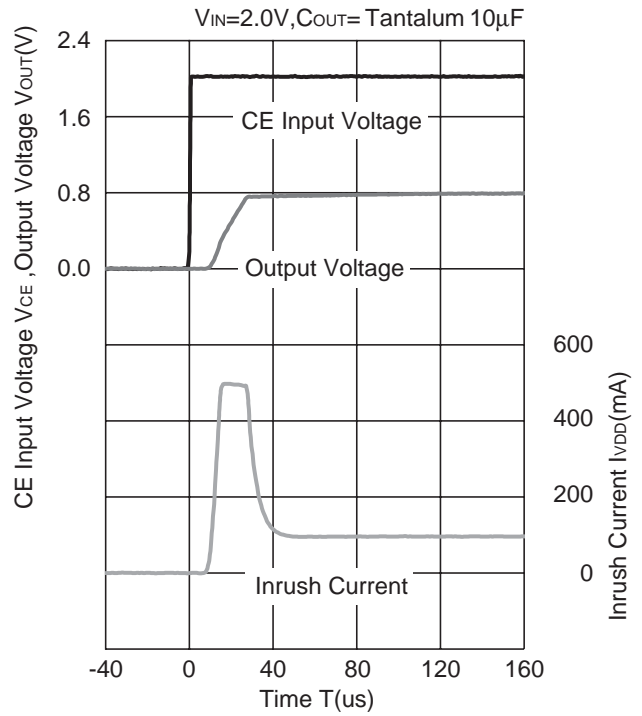

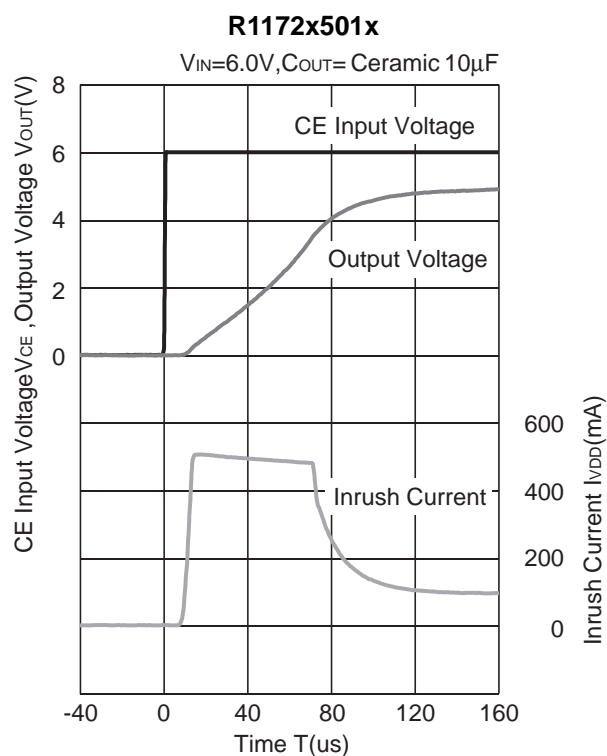
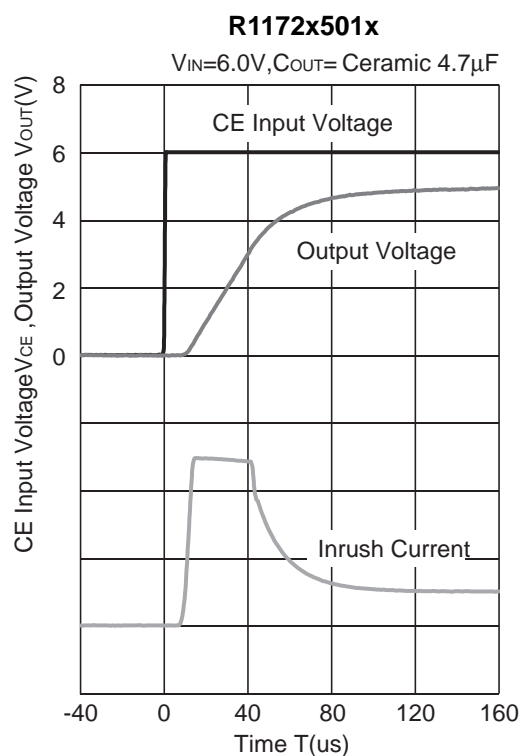
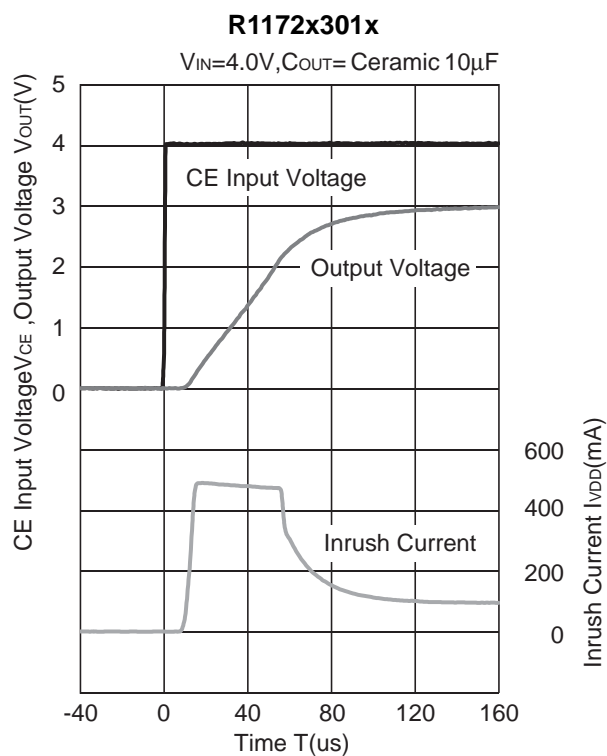
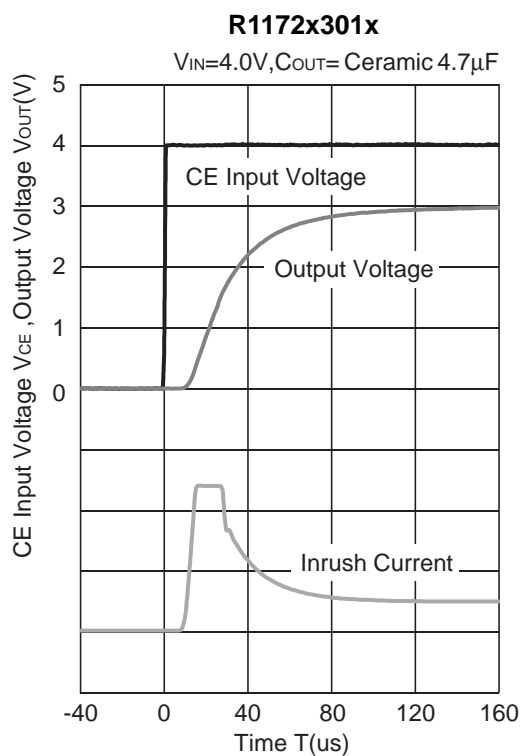

16) Stable Area: ESR limit vs. Load current 0.8V to 3.3V Output type: C<sub>OUT</sub>=4.7μF (Kyocera CM105X5R475M06AB)  
 5.0V Output type: C<sub>OUT</sub>=4.7μF(Kyocera CT21X5R475K06AB)

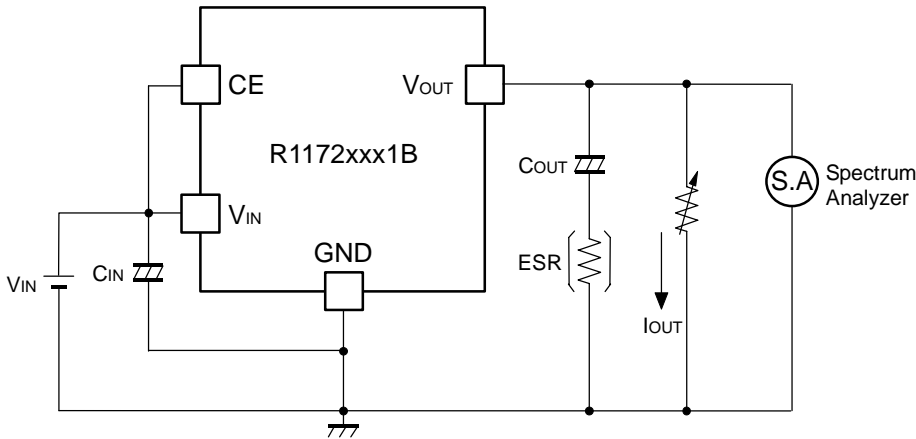

- Measurement Conditions
- V<sub>IN</sub>=V<sub>OUT</sub>+1V
  - Frequency=10Hz to 1MHz
  - T<sub>opt</sub>=25°C

As an output capacitor for this IC, Ceramic capacitor is recommendable. However, other low ESR type capacitor can be used with this IC.

For your reference, noise level is tested, and if the noise level is 40μV or less than 40μV, the ESR values are plotted as stable area. Upper limit is described in the next five graphs, or ESR vs. Output Current. (Hatched area is the stable area.)

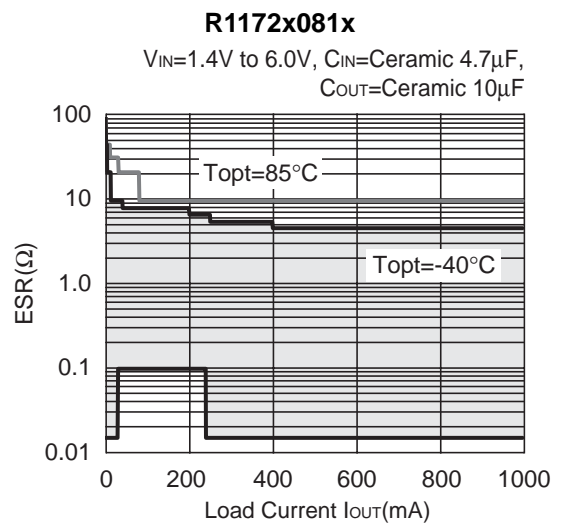
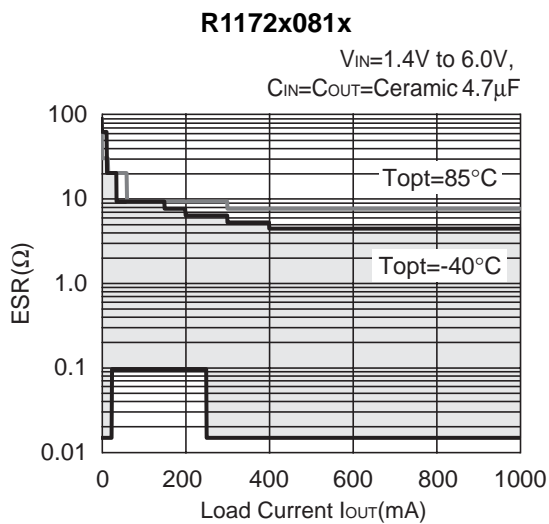

**R1172x101x**

$V_{IN}=1.4V$  to  $6.0V$ ,  
 $C_{IN}=C_{OUT}=\text{Ceramic } 4.7\mu F$

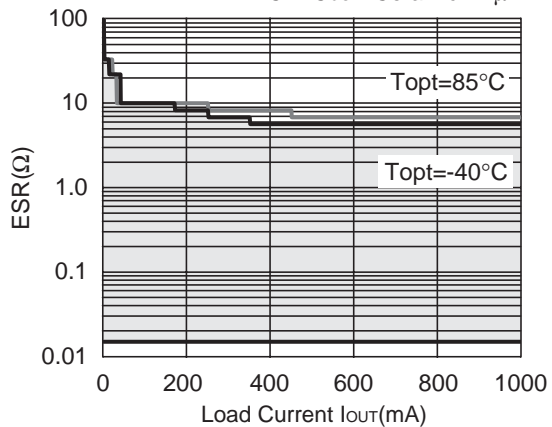

**R1172x301x**

$V_{IN}=3.1V$  to  $6.0V$ ,  
 $C_{IN}=C_{OUT}=\text{Ceramic } 4.7\mu F$

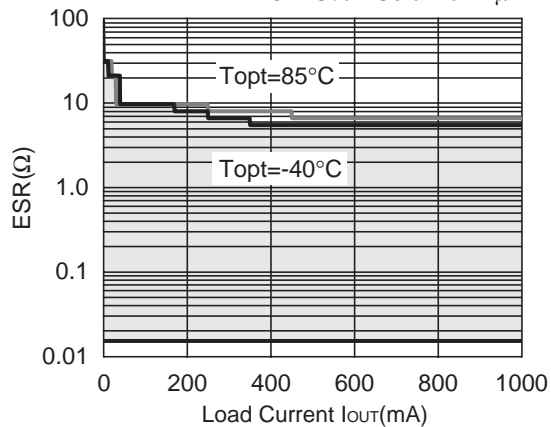

**R1172x501x**

$V_{IN}=5.3V$  to  $6.0V$ ,  
 $C_{IN}=C_{OUT}=\text{Ceramic } 4.7\mu F$

