

**RICOH****LI-ion/POLYMER 1CELL PROTECTOR****R5401xxxxx SERIES****OUTLINE**

The R5401xxxxxx Series are high voltage CMOS-based protection ICs for over-charge/discharge of rechargeable one-cell Lithium-ion (Li+) / Lithium polymer excess load current, further include a short circuit protector for preventing large external short circuit current and excess charge/discharge-current.

Each of these ICs is composed of four voltage detectors, reference units, delay circuits, a short circuit detector, an oscillator, a counter, and logic circuits. When an over-charge voltage crosses the detector threshold from a low value to a high value, the output of C<sub>OUT</sub> pin switches to low level after internal fixed delay time. After detecting over-charge, the detector can be reset and the output of C<sub>OUT</sub> becomes "H" when a kind of load is connected to V<sub>DD</sub> after a charger is disconnected from the battery pack, and the cell voltage becomes lower than over-charge detector threshold. If a charger is continue to be connected to the battery pack, even the cell voltage becomes lower than over-charge detector threshold, over-charge state is not released.

The output of D<sub>OUT</sub> pin, the output of Over-discharge detector and Excess discharge-current detector, switches to low level after internally fixed delay time, when discharged voltage crosses the detector threshold from a high value to a value lower than V<sub>DET2</sub>.

After detecting over-discharge voltage, connect a charger to the battery pack, and when the battery supply voltage becomes higher than over-discharge detector threshold, VD2 is released and the voltage of D<sub>OUT</sub> pin becomes "H" level. Regarding B version, when the cell voltage becomes equal or more than the released voltage from over-discharge, VD2 is released.

An excess discharge-current and short circuit state can be sensed and cut off through the built in excess current detector, VD3, with D<sub>OUT</sub> being enabled to low level. Once after detecting excess discharge-current or short circuit, the VD3 is released and D<sub>OUT</sub> level switches to high by detaching a battery pack from a load system.

After detecting over-discharge, supply current will be kept extremely low by halting internal circuits' operation.

When the C<sub>OUT</sub> is "H", if V- is set at the test shorten mode voltage (Typ. V<sub>SS</sub>-2.0V), the delay time of the PCB can be shortened. Especially, the delay time of over-charge detector can be reduced into approximately 1/57, therefore, testing time of protector circuit board can be reduced. Output type of C<sub>OUT</sub> and D<sub>OUT</sub> is CMOS.

**RICOH**

## FEATURES

- Manufactured with High Voltage Tolerant Process... Absolute Maximum Rating 35V
- Low supply current ..... Supply current(At normal mode) Typ. 4.0μA
- Low supply current ..... (At detecting over-discharge) Max. 0.1μA(A version)  
.....Max. 2.0μA(B version)
- High accuracy detector threshold ..... Over-charge detector (Topt=25°C) ±25mV  
(Topt=-5 to 55°C) ±30mV  
Over-discharge detector ±2.5%  
Excess discharge-current detector ±15mV  
Excess charge-current detector ±30mV
- Variety of detector threshold ..... Over-charge detector threshold 4.0V-4.5V step of 0.005V  
Over-discharge detector threshold 2.0V-3.0V step of 0.005V  
Excess discharge-current threshold 0.05V-0.20V step of 0.005V
- Internal fixed Output delay time.....Over-charge detector Output Delay 1.0s(B version)  
..... 5.0s(A version)  
Over-discharge detector Output Delay 20ms  
Excess discharge-current detector Output Delay 12ms  
Short Circuit detector Output Delay 300μs  
Excess charge-current detector Output Delay 16ms
- Delay Time Reduction Function ..... Set V--(Typ. -2.0V)(Test shorten Mode Voltage) or lower  
with COUT at "H" level, Output Delay time of all items  
except short-circuit can be reduced. (Delay Time for  
over-charge becomes about 1/57 of normal state.)
- 0V-battery charge option..... acceptable
- With Latch function after over-charge detect(B version)
- With Latch function after over-discharge detect(A version)
- Ultra Small package ..... SOT-23-5 / PLP1820-6pin

## APPLICATIONS

- Li+ / Li Polymer protector of over-charge, over-discharge, excess-current for battery pack
- High precision protectors for cell-phones and any other gadgets using on board Li+ / Li Polymer battery

**BLOCK DIAGRAM**

\*A version

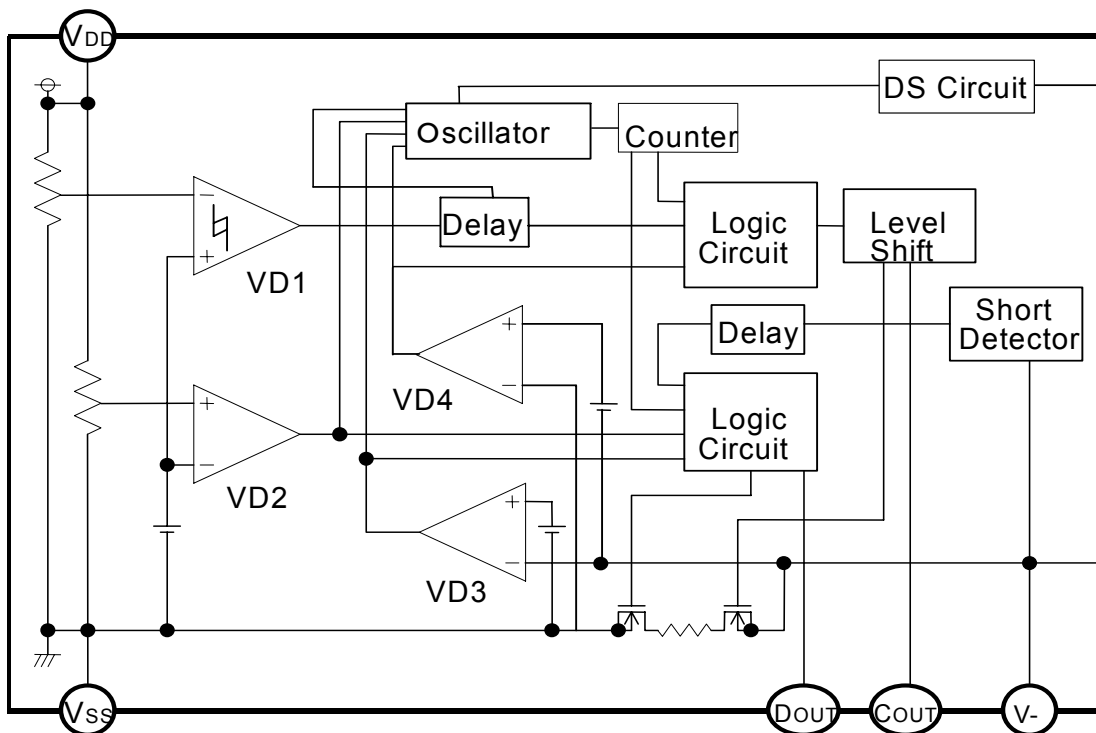

\*B version

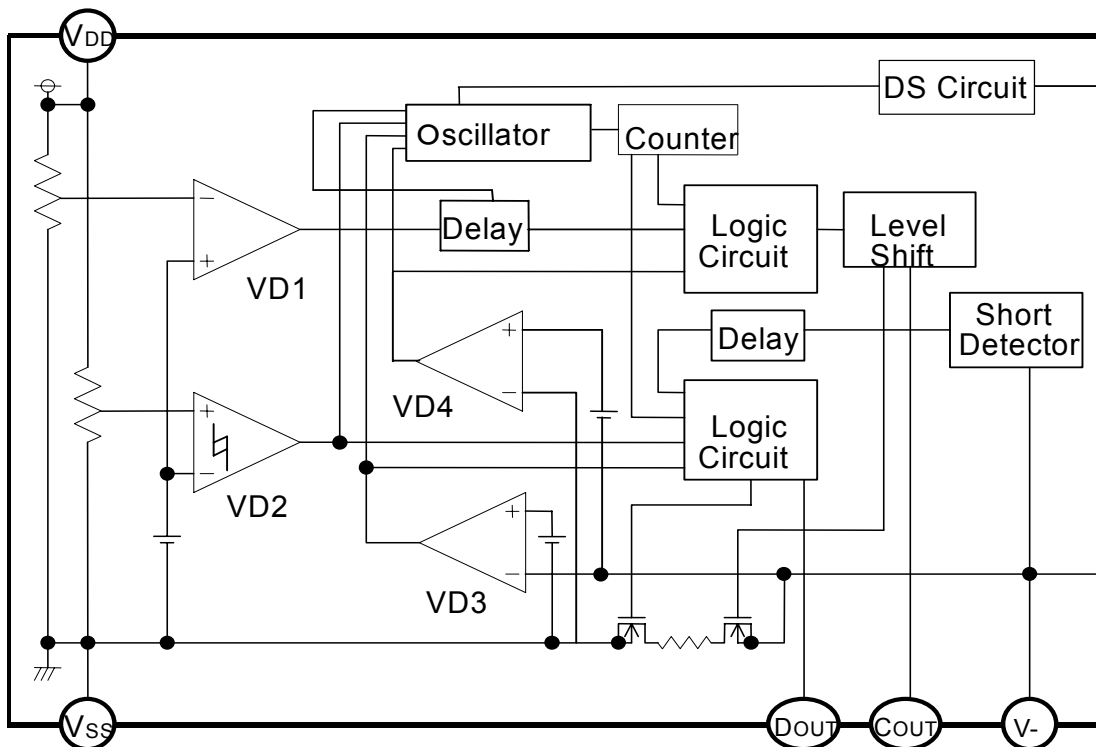

## SELECTION GUIDE

In the R5401xxxxx Series four of the input threshold for over-charge, over-discharge, and excess discharge current detectors, package type etc. can be designated.

Part Number is designated as follows:

R5401x xxxxx-TR ←Part Number  
 ↑ ↑ ↑↑ ↑  
 a b c d e

| Code | Contents   |
|------|--|
| a    | Package Type N: SOT-23-5 K: PLP1820-6  |
| b    | Serial Number for the R5400 Series designating input four threshold for over-charge, over-discharge, and excess charge/discharge-current detectors.  |
| c    | Designation of Output delay time for over-charge and excess charge/discharge-current.  |
| d    | Designation of version symbols<br>A: Release function from over-charge with cell voltage, with latch function at over-discharge detect, with a timer reset delay of over-charge<br>B: With latch function at over-charge, Release function from over-discharge with cell voltage, without a timer reset delay of over-charge |
| e    | Taping Type  |

## PIN CONFIGURATIONS

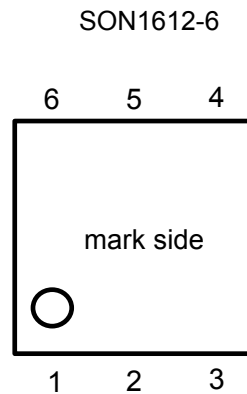
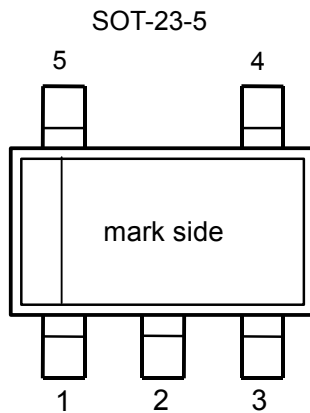

**PIN DESCRIPTION**

| Pin No.  |           | Symbol           | Description  |
|----------|-----------|------------------|--|
| SOT-23-5 | PLP1820-6 |                  |  |
| 1        | 1         | V-               | Pin for charger negative input                           |
| 2        | 5         | V <sub>DD</sub>  | Power supply pin, the substrate voltage level of the IC. |
| 5        | 2         | C <sub>OUT</sub> | Output of over-charge detection, CMOS output             |
| 4        | 3         | D <sub>OUT</sub> | Output of over-discharge detection, CMOS output          |
| -        | 6         | NC               | No Connection  |
| 3        | 4         | V <sub>SS</sub>  | V <sub>SS</sub> pin. Ground pin for the IC               |

**ABSOLUTE MAXIMUM RATINGS**V<sub>SS</sub>=0V

| Symbol            | Item  | Ratings                                      | Unit |
|-------------------|---|--|------|
| V <sub>DD</sub>   | Supply voltage                                      | -0.3 to 12                                   | V    |
| V-                | Input Voltage<br>V- pin(Charger negative input pin) | V <sub>DD</sub> -35 to V <sub>DD</sub> +0.3  | V    |
| V <sub>COUT</sub> | Output voltage<br>C <sub>OUT</sub> pin              | V <sub>DD</sub> -35 to V <sub>DD</sub> +0.3  | V    |
| V <sub>DOUT</sub> | D <sub>OUT</sub> pin                                | V <sub>SS</sub> -0.3 to V <sub>DD</sub> +0.3 | V    |
| P <sub>D</sub>    | Power dissipation                                   | 150  | mW   |
| T <sub>opt</sub>  | Operating temperature range                         | -40 to 85                                    | °C   |
| T <sub>stg</sub>  | Storage temperature range                           | -55 to 125                                   | °C   |

## ELECTRICAL CHARACTERISTICS

A version

Unless otherwise specified, T<sub>opt</sub>=25°C

| Symbol                        | Item   | Conditions   | Min.   | Typ.                                   | Max.   | Unit   |
|-------------------------------|--|--|--|--|--|--------|
| V <sub>DD1</sub>              | Operating input voltage                                  | Voltage defined as V <sub>DD</sub> -V <sub>SS</sub>  | 1.5  |  | 5.0  | V      |
| V <sub>st</sub>               | Minimum operating Voltage for 0V charging *Note 1        | Voltage defined as V <sub>DD</sub> -V <sub>-</sub> , V <sub>DD</sub> -V <sub>SS</sub> =0V      |  |  | 1.8  | V      |
| V <sub>DET1</sub>             | Over-charge threshold                                    | Detect rising edge of supply voltage<br>R1=330Ω<br>R1=330Ω (T <sub>opt</sub> =-5 to 55°C)*Note | V <sub>DET1</sub> -0.025<br>V <sub>DET1</sub> -0.030 | V <sub>DET1</sub><br>V <sub>DET1</sub> | V <sub>DET1</sub> +0.025<br>V <sub>DET1</sub> +0.030 | V<br>V |
| V <sub>REL1</sub>             | Released Voltage from Over-charge                        | R1=330Ω  | V <sub>REL1</sub> -0.05                              | V <sub>REL1</sub>                      | V <sub>REL1</sub> +0.05                              | V      |
| t <sub>VDET1</sub>            | Output delay of over-charge                              | V <sub>DD</sub> =3.6V to 4.4V  | 3.5  | 5.0                                    | 6.5  | s      |
| t <sub>V<sub>DTR1</sub></sub> | Over-charge Detector Timer Reset Delay Time              | V <sub>DD</sub> =3.6V→4.4V→3.6V→4.4V   | 8  | 16                                     | 24   | ms     |
| t <sub>VREL1</sub>            | Output delay of release from over-charge                 | V <sub>DD</sub> =4.5V→3.6V   | 11   | 16                                     | 21   | ms     |
| V <sub>DET2</sub>             | Over-discharge threshold                                 | Detect falling edge of supply voltage  | V <sub>DET2</sub> ×0.975                             | V <sub>DET2</sub>                      | V <sub>DET2</sub> ×1.025                             | V      |
| t <sub>VDET2</sub>            | Output delay of over-discharge                           | V <sub>DD</sub> =3.6V to 2.2V  | 14   | 20                                     | 26   | ms     |
| t <sub>VREL2</sub>            | Output delay of release from over-discharge              | V <sub>DD</sub> =3V V <sub>-</sub> =3V to 0V   | 0.7  | 1.2                                    | 1.7  | ms     |
| V <sub>DET3</sub>             | Excess discharge-current threshold                       | Detect rising edge of 'V-' pin voltage   | V <sub>DET3</sub> -0.015                             | V <sub>DET3</sub>                      | V <sub>DET3</sub> +0.015                             | V      |
| t <sub>VDET3</sub>            | Output delay of excess discharge-current                 | V <sub>DD</sub> =3.0V, V <sub>-</sub> =0V to 1V  | 8  | 12                                     | 16   | ms     |
| t <sub>VREL3</sub>            | Output delay of release from excess discharge-current    | V <sub>DD</sub> =3.0V, V <sub>-</sub> =3V to 0V  | 0.7  | 1.2                                    | 1.7  | ms     |
| V <sub>short</sub>            | Short protection voltage                                 | V <sub>DD</sub> =3.0V  | 0.9  | 1.3                                    | 1.7  | V      |
| t <sub>short</sub>            | Output Delay of Short protection                         | V <sub>DD</sub> =3.0V, V <sub>-</sub> =0V to 3V  | 230  | 300                                    | 500  | μs     |
| R <sub>short</sub>            | Reset resistance for Excess discharge-current protection | V <sub>DD</sub> =3.6V, V <sub>-</sub> =1V  | 25   | 50                                     | 75   | kΩ     |
| V <sub>DET4</sub>             | Excess charge-current threshold                          | Detect falling edge of 'V-' pin voltage  | -0.130   | -0.100                                 | -0.070   | V      |
| t <sub>VDET4</sub>            | Output delay of excess charge-current                    | V <sub>DD</sub> =3.0V, V <sub>-</sub> =0V to -1V   | 11   | 16                                     | 21   | ms     |
| t <sub>VREL4</sub>            | Output delay of release from excess charge-current       | V <sub>DD</sub> =3.0V, V <sub>-</sub> =-1V to 0V   | 0.7  | 1.2                                    | 1.7  | ms     |
| V <sub>DS</sub>               | Output Delay Time Reduction Mode Voltage                 | V <sub>DD</sub> =4.4V  | -1.4   | -2.0                                   | -2.6   | V      |
| V <sub>OL1</sub>              | Nch ON voltage of COUT                                   | I <sub>ol</sub> =50μA, V <sub>DD</sub> =4.5V   |  | 0.4                                    | 0.5  | V      |
| V <sub>OH1</sub>              | Pch ON voltage of COUT                                   | I <sub>oh</sub> =-50μA, V <sub>DD</sub> =3.9V  | 3.4  | 3.7                                    |  | V      |
| V <sub>OL2</sub>              | Nch ON voltage of DOUT                                   | I <sub>ol</sub> =50μA, V <sub>DD</sub> =2.0V   |  | 0.2                                    | 0.5  | V      |
| V <sub>OH2</sub>              | Pch ON voltage of DOUT                                   | I <sub>oh</sub> =-50μA, V <sub>DD</sub> =3.9V  | 3.4  | 3.7                                    |  | V      |
| I <sub>DD</sub>               | Supply current   | V <sub>DD</sub> =3.9V, V <sub>-</sub> =0V  |  | 4.0                                    | 8.0  | μA     |
| I <sub>s</sub>                | Standby current  | V <sub>DD</sub> =2.0V  |  |  | 0.1  | μA     |

\*Note: We compensate for this characteristic related to temperature by laser-trim, however, this specification is guaranteed by design, not mass production tested.

B version

Unless otherwise specified, T<sub>opt</sub>=25°C

| Symbol             | Item   | Conditions   | Min.   | Typ.                                   | Max.   | Unit   |
|--------------------|--|--|--|--|--|--------|
| V <sub>DD1</sub>   | Operating input voltage                                      | Voltage defined as V <sub>DD</sub> -V <sub>SS</sub>  | 1.5  |  | 5.0  | V      |
| V <sub>st</sub>    | Minimum operating Voltage for 0V charging <sup>*Note 1</sup> | Voltage defined as V <sub>DD</sub> -V <sub>-</sub> , V <sub>DD</sub> -V <sub>SS</sub> =0V                  |  |  | 1.8  | V      |
| V <sub>DET1</sub>  | Over-charge threshold  | Detect rising edge of supply voltage<br>R1=330Ω<br>R1=330Ω (T <sub>opt</sub> =-5 to 55°C) <sup>*Note</sup> | V <sub>DET1</sub> -0.025<br>V <sub>DET1</sub> -0.030 | V <sub>DET1</sub><br>V <sub>DET1</sub> | V <sub>DET1</sub> +0.025<br>V <sub>DET1</sub> +0.030 | V<br>V |
| t <sub>VDET1</sub> | Output delay of over-charge                                  | V <sub>DD</sub> =3.6V to 4.4V  | 0.7  | 1.0                                    | 1.3  | s      |
| t <sub>VREL1</sub> | Output delay of release from over-charge                     | V <sub>DD</sub> =4.5V→3.6V   | 11   | 16                                     | 21   | ms     |
| V <sub>DET2</sub>  | Over-discharge threshold                                     | Detect falling edge of supply voltage  | V <sub>DET2</sub> ×0.975                             | V <sub>DET2</sub>                      | V <sub>DET2</sub> ×1.025                             | V      |
| t <sub>VDET2</sub> | Output delay of over-discharge                               | V <sub>DD</sub> =3.6V to 2.2V  | V <sub>REL2</sub> ×0.974                             | V <sub>REL2</sub>                      | V <sub>REL2</sub> ×1.026                             | ms     |
| t <sub>VREL2</sub> | Output delay of release from over-discharge                  | V <sub>DD</sub> =3V V <sub>-</sub> =3V to 0V   | 0.7  | 1.2                                    | 1.7  | ms     |
| V <sub>DET3</sub>  | Excess discharge-current threshold                           | Detect rising edge of 'V-' pin voltage   | V <sub>DET3</sub> -0.015                             | V <sub>DET3</sub>                      | V <sub>DET3</sub> +0.015                             | V      |
| t <sub>VDET3</sub> | Output delay of excess discharge-current                     | V <sub>DD</sub> =3.0V, V <sub>-</sub> =0V to 1V  | 8  | 12                                     | 16   | ms     |
| t <sub>VREL3</sub> | Output delay of release from excess discharge-current        | V <sub>DD</sub> =3.0V, V <sub>-</sub> =3V to 0V  | 0.7  | 1.2                                    | 1.7  | ms     |
| V <sub>short</sub> | Short protection voltage                                     | V <sub>DD</sub> =3.0V  | 0.9  | 1.3                                    | 1.7  | V      |
| t <sub>short</sub> | Output Delay of Short protection                             | V <sub>DD</sub> =3.0V, V <sub>-</sub> =0V to 3V  | 230  | 300                                    | 500  | μs     |
| R <sub>short</sub> | Reset resistance for Excess discharge-current protection     | V <sub>DD</sub> =3.6V, V <sub>-</sub> =1V  | 25   | 50                                     | 75   | kΩ     |
| V <sub>DET4</sub>  | Excess charge-current threshold                              | Detect falling edge of 'V-' pin voltage  | -0.130   | -0.100                                 | -0.070   | V      |
| t <sub>VDET4</sub> | Output delay of excess charge-current                        | V <sub>DD</sub> =3.0V, V <sub>-</sub> =0V to -1V   | 11   | 16                                     | 21   | ms     |
| t <sub>VREL4</sub> | Output delay of release from excess charge-current           | V <sub>DD</sub> =3.0V, V <sub>-</sub> =-1V to 0V   | 0.7  | 1.2                                    | 1.7  | ms     |
| V <sub>DS</sub>    | Output Delay Time Reduction Mode Voltage                     | V <sub>DD</sub> =4.4V  | -1.4   | -2.0                                   | -2.6   | V      |
| V <sub>OL1</sub>   | Nch ON voltage of COUT                                       | I <sub>ol</sub> =50μA, V <sub>DD</sub> =4.5V   |  | 0.4                                    | 0.5  | V      |
| V <sub>OH1</sub>   | Pch ON voltage of COUT                                       | I <sub>oh</sub> =-50μA, V <sub>DD</sub> =3.9V  | 3.4  | 3.7                                    |  | V      |
| V <sub>OL2</sub>   | Nch ON voltage of DOUT                                       | I <sub>ol</sub> =50μA, V <sub>DD</sub> =2.0V   |  | 0.2                                    | 0.5  | V      |
| V <sub>OH2</sub>   | Pch ON voltage of DOUT                                       | I <sub>oh</sub> =-50μA, V <sub>DD</sub> =3.9V  | 3.4  | 3.7                                    |  | V      |
| I <sub>DD</sub>    | Supply current   | V <sub>DD</sub> =3.9V, V <sub>-</sub> =0V  |  | 4.0                                    | 8.0  | μA     |
| I <sub>S</sub>     | Standby current  | V <sub>DD</sub> =2.0V  |  |  | 2.0  | μA     |

\*Note: We compensate for this characteristic related to temperature by laser-trim, however, this specification is guaranteed by design, not mass production tested.

## OPERATION

### • VD1 / Over-Charge Detector

The VD1 monitors  $V_{DD}$  pin voltage while charge the battery pack. When the  $V_{DD}$  voltage crosses over-charge detector threshold  $V_{DET1}$  from a low value to a value higher than the  $V_{DET1}$ , the VD1 can sense a over-charging and an external charge control Nch MOSFET turns off with  $C_{OUT}$  pin being at "L" level.

In terms of A version, after detecting over-charge, when the voltage of  $V_{DD}$  pin is less than the release voltage from over-charge, if the charger is removed and connect a load, VD1 is released. Then the output level of  $C_{OUT}$  becomes "H" and by turning on the external Nch-MOSFET, the battery charger is ready to work again. In other words, once detecting over-charge, even if the battery voltage becomes equal or lower than the released voltage from over-charge, while the charger is connected, the voltage difference between a charger voltage and cell voltage, there may be a case of excess charge current status. So the over-charge voltage is released, however, over-charge current is detected, therefore, recharge is not accepted. After detecting over-charge, if the  $V_{DD}$  voltage becomes lower than the released voltage from over-charge, and the voltage difference between the charger and the cell does not make over-charge current status, VD1 is released and becomes rechargeable. Therefore, there is a hysteresis range for VD1.

In terms of B version, after detecting over-charge, when the voltage of  $V_{DD}$  pin is less than over-charge detector threshold, if the charger is removed and connect a load, VD1 is released, then the output level of  $C_{OUT}$  becomes "H" and by turning on the external Nch-MOSFET, the battery charger is ready to work again. In other words, once detecting over-charge, even if the battery voltage is down, while the charger is connected, recharge is not accepted. Thus, there is no hysteresis for over-charge detector. To judge whether or not a load is connected, over-discharge detector is used. By connecting a load, when the  $V_{-}$  pin voltage becomes equal or more than over-discharge current detector threshold, this IC recognizes connecting a load, then released from over-charge.

After detecting over-charge with the  $V_{DD}$  voltage of higher than  $V_{DET1}$ , disconnecting a charger and connecting system load to the battery pack makes load current allowable through parasitic diode of external charge control FET.

The  $C_{OUT}$  level would be "H" when the  $V_{DD}$  level is down to a level below the  $V_{DET1}$  by continuous drawing of load current.

In terms of A version, output delay times for over-charge detect, over-charge detector timer reset, and released from over-charge are internally fixed respectively. Although the  $V_{DD}$  voltage goes up to a higher level than over-charge detector threshold within the output delay time, VD1 would not work for detecting over-charge. Besides, if  $V_{DD}$  pin voltage becomes lower than the over-charge detector threshold by noise or something, within output delay time for VD1, and if the time period is less than over-charge detector timer reset delay time, the time period is accumulated. As a result, the accumulated delay time reaches output delay time for over-charge, over-charge is detected. If  $V_{DD}$  pin voltage is equal or more than over-charge detector threshold, within output delay time for over-charge, the time period being lower than over-charge detector threshold becomes equal or more than over-charge timer reset delay time, the accumulated delay time for over-charge is reset. If the action for VD1 to release is done and the condition returns to the initial one within the output delay time, VD1 cannot be released.

In terms of B version, internal fixed output delay times for over-charge detection and release from over-charge exist. Even when the  $V_{DD}$  level becomes a higher level than  $V_{DET1}$  if the  $V_{DD}$  voltage would be back to a level lower than the  $V_{DET1}$  within a time period of the output delay time, VD1 would not output a signal for turning off the charge control FET. Besides, after detecting over-charge, while the  $V_{DD}$  is

---

lower than over-charge detector, even if a charger is removed and connect a load, when the voltage is recovered within output delay time of release from over-charge, over-charge state is not released.

A level shifter incorporated in a buffer driver for the  $C_{OUT}$  pin makes the "L" level of  $C_{OUT}$  pin to the  $V_{-}$  pin voltage and the "H" level of  $C_{OUT}$  pin is set to  $V_{DD}$  voltage with CMOS buffer.

- **VD2 / Over-Discharge Detector**

The VD2 is monitoring a  $V_{DD}$  pin voltage. When the  $V_{DD}$  voltage crosses the over-discharge detector threshold  $V_{DET2}$  from a high value to a value lower than the  $V_{DET2}$ , the VD2 can sense an over-discharging and the external discharge control Nch MOSFET turns off with the  $D_{OUT}$  pin being at "L" level.

In terms of A version, to reset the VD2 with the  $D_{OUT}$  pin level being "H" again after detecting over-discharge, if  $V_{DD}$  voltage is equal or less than over-charge detector threshold, a charge current flows through a parasitic diode of the external Nch MOSFET. After that, when  $V_{DD}$  voltage is more than over-discharge threshold,  $D_{OUT}$  pin becomes "H", and by tuning on the external Nch MOSFET, discharge is possible. In the case that a charger is connected to the battery pack, and  $V_{DD}$  level is more than over-discharge detector threshold, the output level of  $D_{OUT}$  becomes "H" immediately.

In terms of B version, to reset the VD2 with the  $D_{OUT}$  pin level being "H" again after detecting over-discharge, the operation is same as A version. Besides, without connecting a charger, if  $V_{DD}$  pin voltage is equal or more than the released voltage from over-discharge, the output level of  $D_{OUT}$  becomes "H".

When a cell voltage equals to zero, the voltage of a charger is equal or more than 0V-charge minimum voltage ( $V_{st}$ ),  $C_{OUT}$  pin becomes "H" and system allowable to charge.

An output delay time for over-discharge detection is fixed internally. When the  $V_{DD}$  level is down to a lower level than  $V_{DET2}$  if the  $V_{DD}$  voltage would be back to a level higher than the  $V_{DET2}$  within a time period of the output delay time, VD2 would not output a signal for turning off the discharge control FET. Output delay time for release from over-discharge is also set.

After detecting of over-discharge by VD2, supply current would be reduced and be into standby by halting unnecessary circuits and consumption current of IC itself is minimized.

The output type of  $D_{OUT}$  pin is CMOS having "H" level of  $V_{DD}$  and "L" level of  $V_{SS}$ .

- **VD3 /Excess discharge-current Detector, Short Circuit Protector**

Both of the excess current detector and short circuit protection can work when the both of control FETs are in "ON" state.

When the  $V_{-}$  pin voltage is up to a value between the short protection voltage  $V_{short}$  and excess discharge-current threshold  $V_{DET3}$ , VD3 operates and further soaring of  $V_{-}$  pin voltage higher than  $V_{short}$  makes the short circuit protector enabled. This leads the external discharge control Nch MOSFET turns off with the  $D_{OUT}$  pin being at "L" level and prevents the circuit from a large current flowing. The output delay time for detecting excess discharge current is fixed inside the IC.

A quick recovery of  $V_{-}$  pin level from a value between  $V_{short}$  and  $V_{DET3}$  within the delay time keeps the discharge control FET staying "H" state. Output delay time for Release from excess dis-

charge-current detection is also set.

When the short circuit protector is enabled, the  $D_{OUT}$  would be "L" and its delay time also exists.

The V - pin has a built-in pulled down resistor with connecting to the  $V_{SS}$  pin.

After an excess discharge-current or short circuit protection is detected, removing a cause of excess discharge-current or external short circuit makes an external discharge control FET to an "ON" state automatically with the V- pin level being down to the  $V_{SS}$  level through built-in pulled down resistor. When the V- pin voltage is equal or less than excess-discharge current detector threshold, the circuit is released from excess discharge or short circuit. The reset resistor of excess discharge-current is off at normal state. Only when detecting excess discharge-current or short circuit, the resistor is on.

Output delay time of excess discharge-current is set shorter than the delay time for over-discharge detector. Therefore, if  $V_{DD}$  voltage would be lower than  $V_{DET2}$  at the same time as the excess discharge-current is detected, the R5401xxxxxx is at excess discharge-current detection mode. By disconnecting a load, VD3 is automatically released from excess discharge-current.

- **VD4/ Excess charge-current detector**

While charge and discharge are acceptable with the battery pack, VD4 senses V- pin voltage. For example, if the battery pack is charged by an inappropriate charger, excess current flows, then the voltage of V- pin becomes equal or less than excess charge-current detector threshold. Then, the output of  $C_{OUT}$  becomes "L", and protects against flowing excess current in the circuit by turning off the external Nch MOSFET.

Output delay of excess charge current is internally fixed. Even the voltage level of V- pin becomes equal or lower than excess charge-current detector threshold, if the voltage is higher than the VD4 threshold within the delay time, excess charge-current state is not detected. Output delay time for release from excess charge current is also set internally.

VD4 can be released by disconnecting a charger and setting a load.

- **DS (Delay Shorten) function**

Output delay time of over-charge and over-discharge and release from those detecting modes can be shorter than those setting value by forcing the test shorten mode voltage or lower than that to V- pin.

## TIMING CHART

A version

### 1. Detect and Release from Over-charge Operation

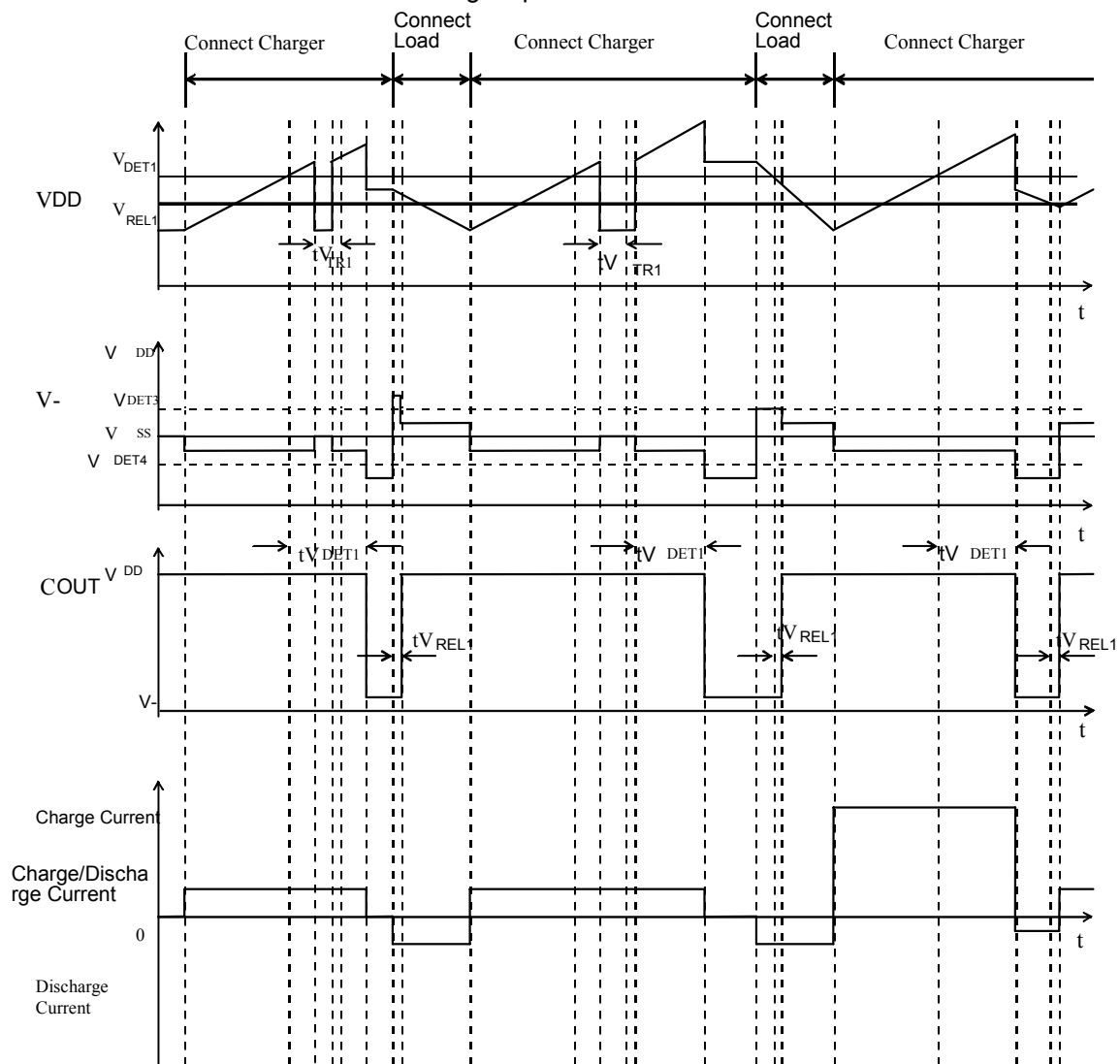

(2) Over-charge Timer Reset Operation

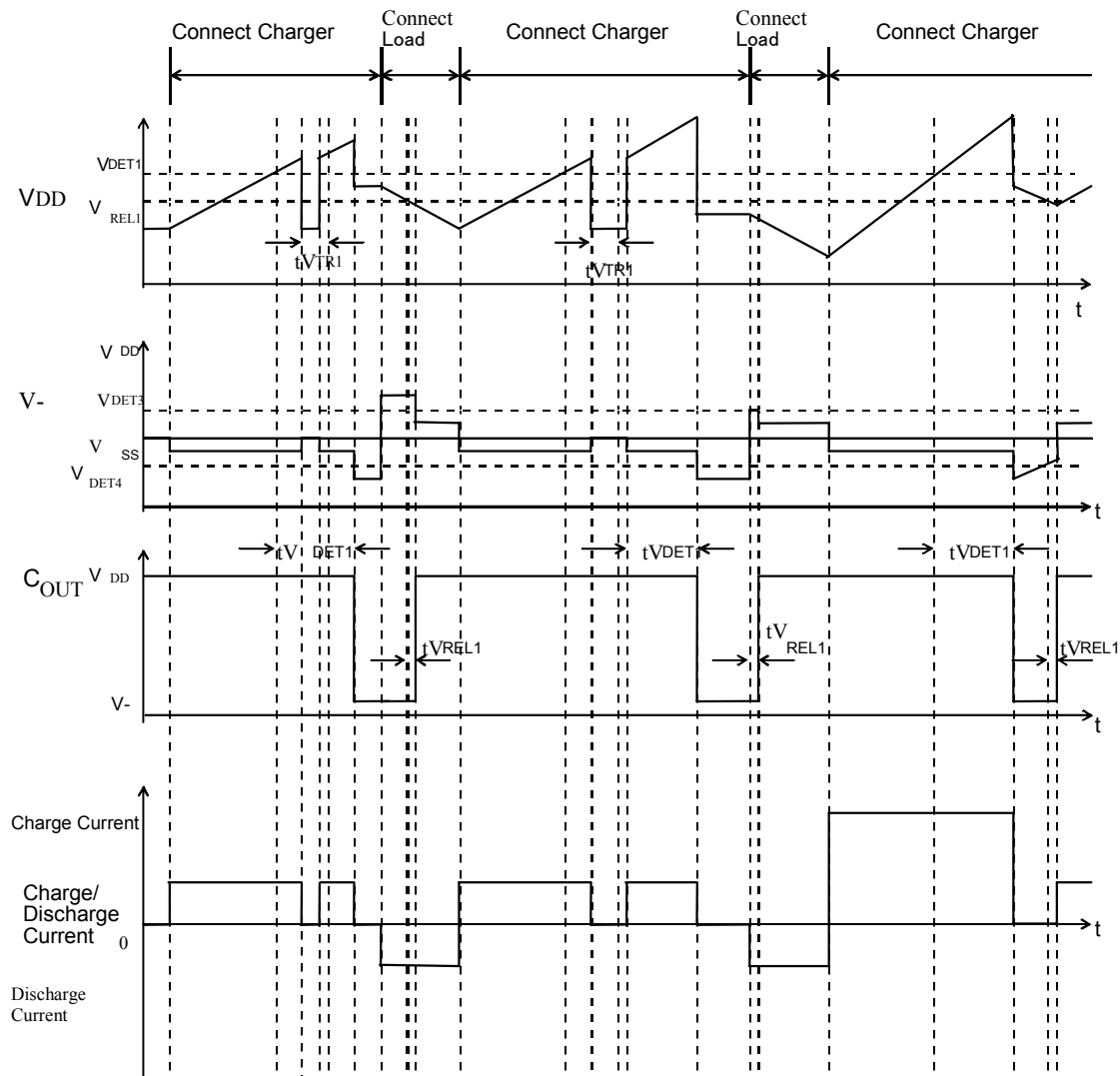

(3) Over-discharge, Excess discharge current, Short circuit

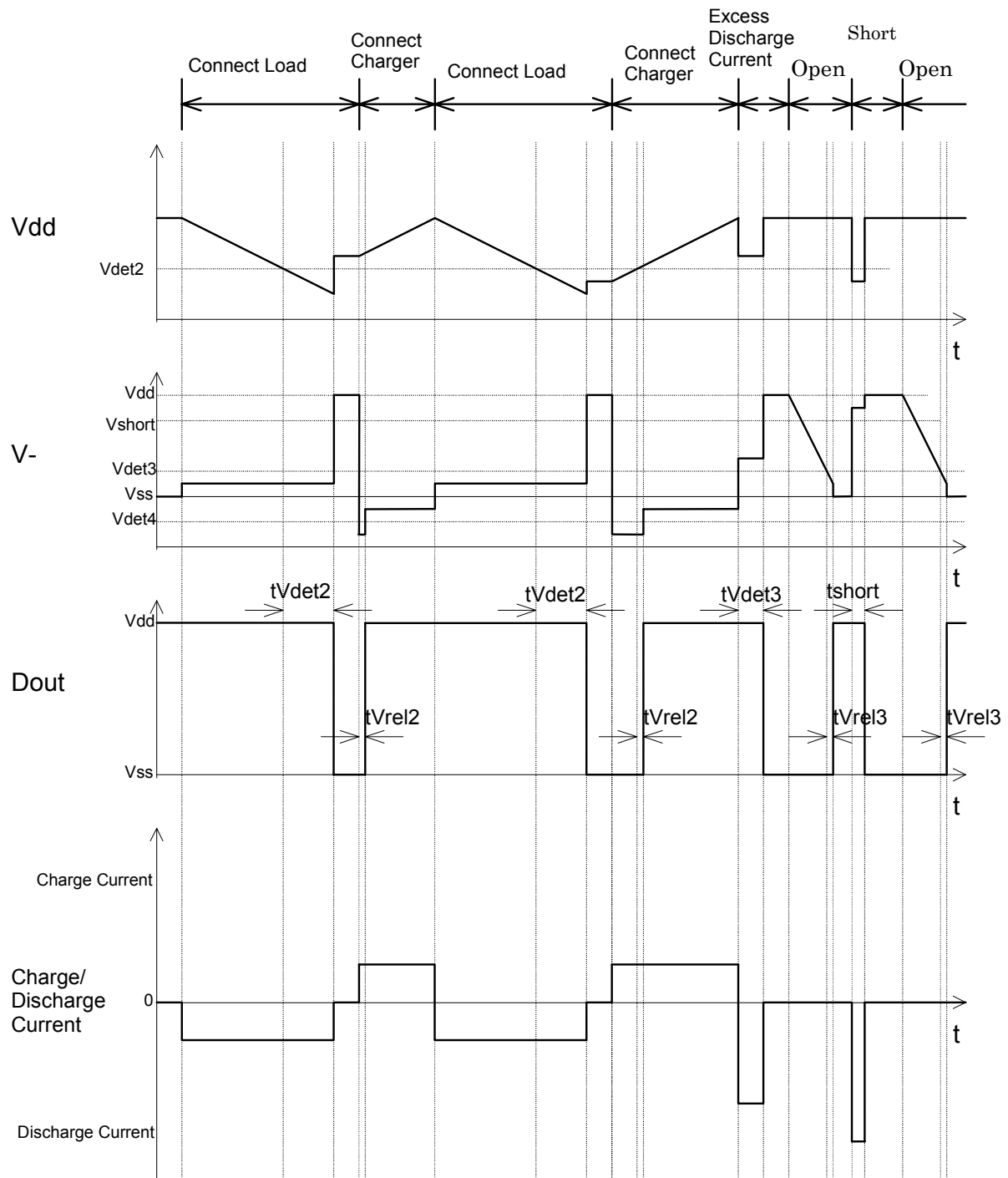

B version

4. Timing diagram of over-charge voltage and over-charge current

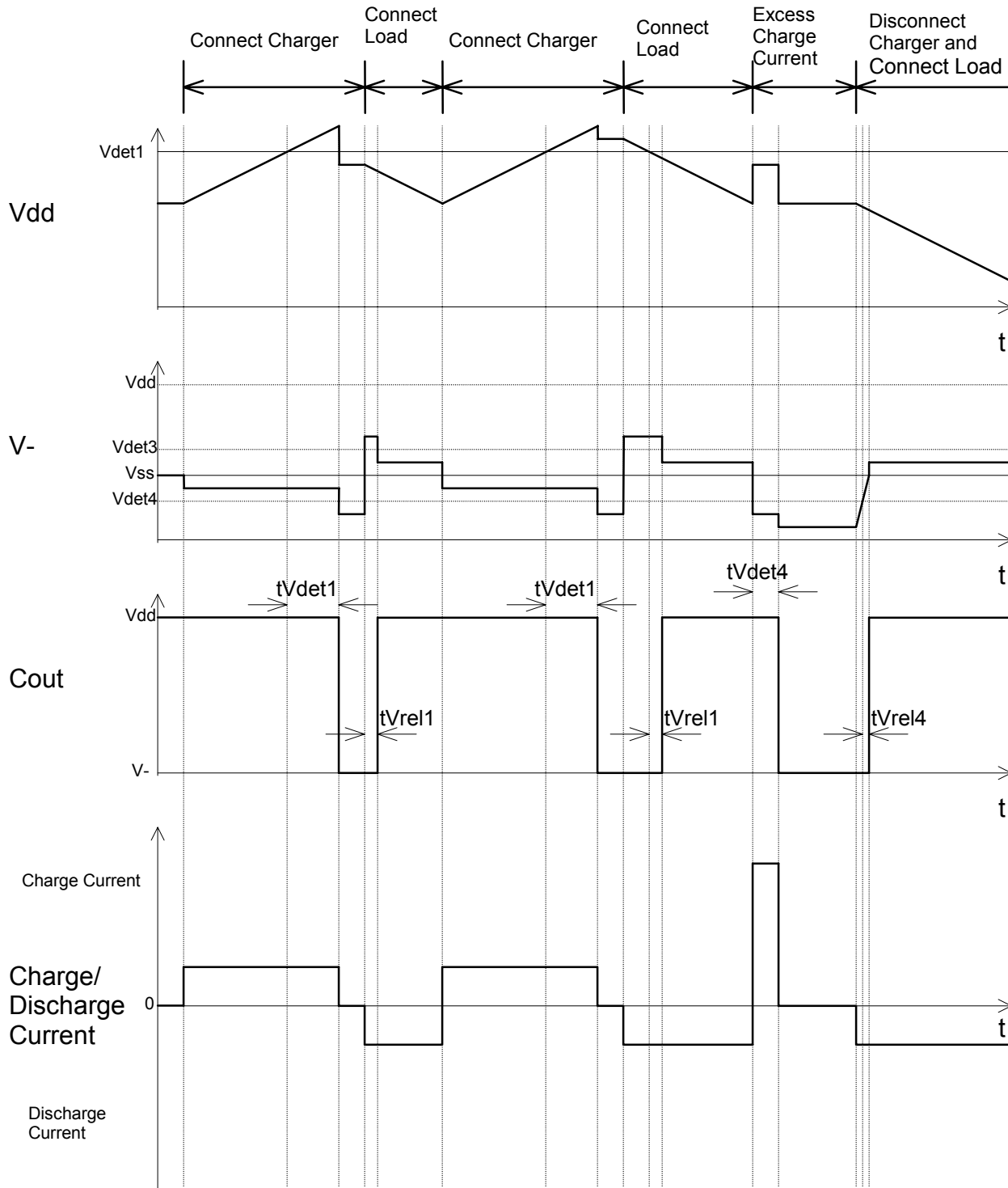

5. Over discharge, Excess-discharge current, Short-circuit operation

