

## PCMCIA Power Controller

### DESCRIPTION

The R5534V switches between the three VCC voltages (0V/3.3V/5.0V) and the VPP voltages (off/0V/3.3V/5.0V). The R5534V has two sets of VCC output and VPP output each, therefore it fits dual slot models. If VCC pin or VPP pin may be clamped to the GND, short current limit works at 1A(Min.) for VCC and 0.15A(Min.) for VPP.

The R5534V is suitable for standard PCMCIA power controllers.

### FEATURES

- Low on resistance P-channel MOSFET Switch
- Dual Slot Power Supply Control
- Over- Current Limit Protection
- Thermal Shutdown Protection
- Low Consumption Current
- Break-Before-Make Switching
- SSOP-20 pin Package

### APPLICATIONS

- Dual Slot PC card Power Supply Pin Voltage Switch
- Card-bus Slot Power Supply Control
- PC Card Reader/Writer

### PIN CONFIGURATION

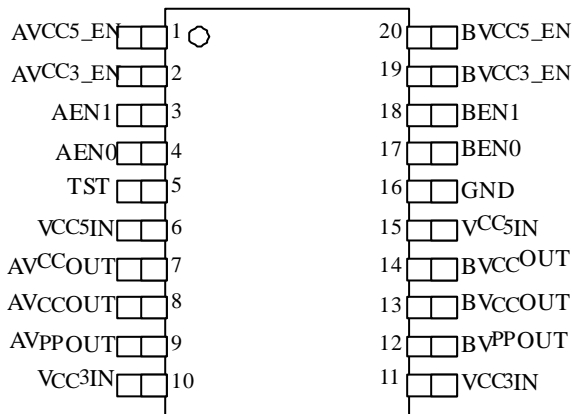

\*Note: Same name pins should be connected one another.  
Connect TST pin to V<sub>CC5IN</sub> pin.

## ■ BLOCK DIAGRAM

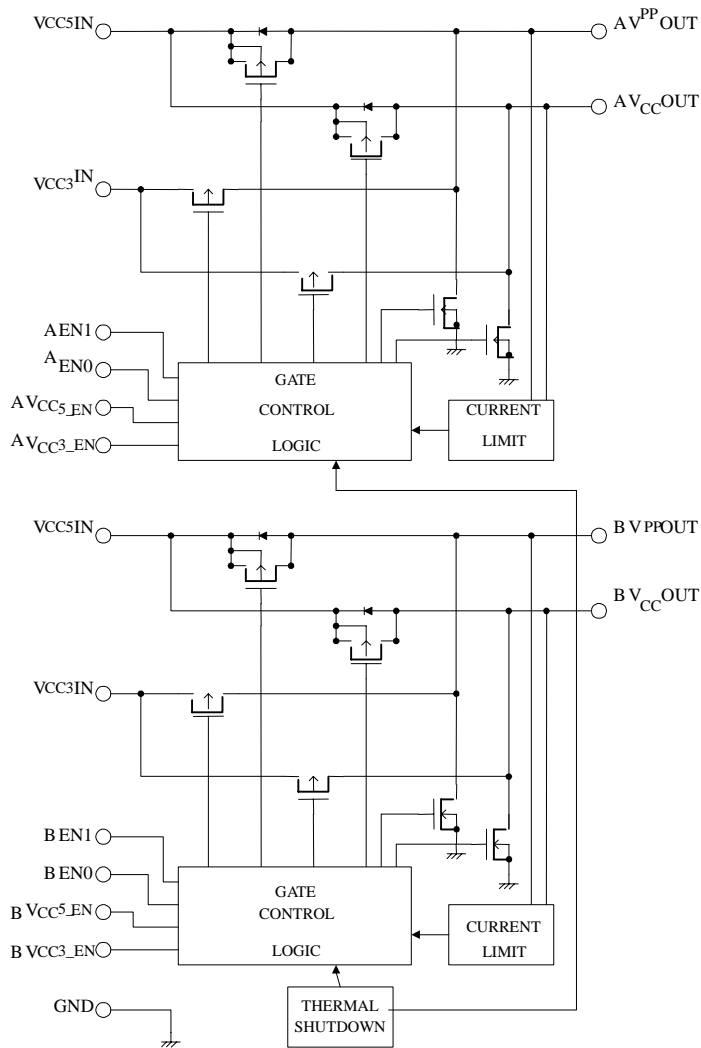

## ■ PIN DESCRIPTION

| Symbol  | Pin description |
|---------|-----------------|
| VCC5IN  | 5V Input Pin    |
| VCC3IN  | 3V Input Pin    |
| GND     | Ground Pin      |
| VCC5_EN | Logic Input Pin |
| VCC3_EN | Logic Input Pin |
| EN1     | Logic Input Pin |
| EN0     | Logic Input Pin |
| VCCOUT  | Vcc Output Pin  |
| VPPOUT  | VPP Output Pin  |
| TST     | Test Pin        |

## ■ ABSOLUTE MAXIMUM RATINGS

Topt=25°C

| Item                        | Symbol              | Conditions | Ratings                   | Unit |
|-----------------------------|---------------------|------------|---------------------------|------|
| Input Voltage(5V)           | V <sub>cc5IN</sub>  |            | -0.3 to 6.0               | V    |
| Input Voltage(3V)           | V <sub>cc3IN</sub>  |            | -0.3 to 6.0               | V    |
| Logic Input Voltage         | V <sub>IN</sub>     |            | -0.3 to 6.0               | V    |
| TST Input Voltage           | V <sub>TST</sub>    |            | -0.3 to 6.0               | V    |
| Output Current              | I <sub>O(VCC)</sub> | Each Slot  | >1A , Internal Limited    |      |
|                             | I <sub>O(VPP)</sub> | Each Slot  | >150mA , Internal Limited |      |
| Power Dissipation           | P <sub>D</sub>      |            | Internal Limited          |      |
| Operating Temperature Range | Topt                |            | -40 to 85                 | °C   |
| Storage Temperature Range   | Tstg                |            | -55 to 125                | °C   |

\*Note: Absolute maximum ratings are threshold limit values that must not be exceeded even for any moment under any conditions. More over, such values for any two or more items of the ratings must not be reached simultaneously. Operation above these absolute maximum ratings may cause degradation or fatal damage to the device. These mean stress ratings and do not necessarily imply functional operation below these limits.

## ELECTRICAL CHARACTERISTICS

Top<sub>t</sub>=25°C

| Symbol                       | Item  | Conditions  | Min. | Typ. | Max. | Unit |
|------------------------------|---|---|------|------|------|------|
| V <sub>cc5</sub>             | Supply Voltage(5V)                                  |   | 3.0  | 5.0  | 5.5  | V    |
| V <sub>cc3</sub>             | Supply Voltage(3V)                                  |   | 3.0  | 3.3  | 5.5  | V    |
| I <sub>cc5</sub>             | Supply Current                                      | V <sub>cc</sub> OUT = 5V or 3.3V                          |      | 60   | 120  | μA   |
| I <sub>S<sub>L</sub>P5</sub> |   | V <sub>cc</sub> OUT = 0V (sleep mode)                     |      | 0.2  | 10.0 | μA   |
| I <sub>CC3</sub>             |   | V <sub>cc</sub> OUT = 5V or 3.3V                          |      | 20   | 60   | μA   |
| I <sub>S<sub>L</sub>P3</sub> |   | V <sub>cc</sub> OUT = 0V (sleep mode)                     |      | 0.1  | 10   | μA   |
| RoV <sub>cc</sub>            | V <sub>cc</sub> OUT switch resistance               | Select V <sub>cc</sub> OUT=5V, V <sub>cc5</sub> IN=5.0V   |      | 110  | 170  | mΩ   |
|                              |   | Select V <sub>cc</sub> OUT=3.3V, V <sub>cc3</sub> IN=3.3V |      | 130  | 180  | mΩ   |
|                              |   | Select V <sub>cc</sub> OUT=0V, V <sub>cc5</sub> IN=5.0V   |      | 500  | 3900 | Ω    |
| RoV <sub>pp</sub>            | V <sub>pp</sub> OUT switch resistance               | Select V <sub>pp</sub> OUT=5V, V <sub>cc5</sub> IN=5.0V   |      | 2.1  | 3.5  | Ω    |
|                              |   | Select V <sub>pp</sub> OUT=3.3V, V <sub>cc3</sub> IN=3.3V |      | 3.3  | 5.5  | Ω    |
|                              |   | Select V <sub>pp</sub> OUT=0V, V <sub>cc5</sub> IN=5.0V   |      | 2500 | 3900 | Ω    |
| IPPL                         | V <sub>pp</sub> OUT Leakage Current                 | Select V <sub>pp</sub> OUT=Hi-Z                           |      | 1    | 10   | μA   |
| ICCSC                        | Short Current Limit                                 | V <sub>cc</sub> OUT=0V                                    | 1    | 1.5  |      | A    |
| IPpsc                        |   | V <sub>pp</sub> OUT=0V                                    | 0.15 | 0.40 |      | A    |
| V <sub>IH</sub>              | Logic Input "H" Voltage                             |   | 2.2  |      | 6.0  | V    |
| V <sub>IL</sub>              | Logic Input "L" Voltage                             |   | -0.3 |      | 0.8  | V    |
| I <sub>IN</sub>              | Logic Input Current                                 |   | -1   |      | 1    | μA   |
| TSD                          | Thermal Shutdown Temperature                        |   |      | 135  |      | °C   |
| t <sub>1</sub>               | V <sub>cc</sub> Turn-on Delay Time<br>(*Note 2)     | V <sub>cc</sub> OUT=0V to 10% of 3.3V(Select 3.3V)        |      | 200  |      | μs   |
| t <sub>2</sub>               |   | V <sub>cc</sub> OUT=0V to 10% of 5.0V(Select 5V)          |      | 400  |      | μs   |
| t <sub>3</sub>               | V <sub>cc</sub> Rising Time (*Note 2)               | V <sub>cc</sub> OUT=10% to 90% of 3.3V(Select 3.3V)       |      | 800  |      | μs   |
| t <sub>4</sub>               |   | V <sub>cc</sub> OUT=10% to 90% of 5.0V(Select 5V)         |      | 2300 |      | μs   |
| t <sub>7</sub>               | V <sub>cc</sub> Turn-off Delay Time<br>(*Note1,2,4) | V <sub>cc</sub> OUT=3.3V to Hi-Z                          |      | 2.3  |      | ms   |
| t <sub>8</sub>               |   | V <sub>cc</sub> OUT=5V to Hi-Z                            |      | 2.8  |      | ms   |
| t <sub>5</sub>               | V <sub>cc</sub> Falling Time (*Note 3)              | V <sub>cc</sub> OUT=90% to 10% of 3.3V(Select 3.3V)       |      | 800  |      | μs   |
| t <sub>6</sub>               |   | V <sub>cc</sub> OUT=90% to 10% of 5.0V(Select 5V)         |      | 700  |      | μs   |
| t <sub>9</sub>               | V <sub>pp</sub> Turn-on Delay Time<br>(*Note 3)     | V <sub>pp</sub> OUT=0V to 10% of 3.3V(Select 3.3V)        |      | 5    |      | μs   |
| t <sub>10</sub>              |   | V <sub>pp</sub> OUT=0V to 10% of 5.0V(Select 5V)          |      | 12   |      | μs   |
| t <sub>11</sub>              | V <sub>pp</sub> Rising Time (*Note 3)               | V <sub>pp</sub> OUT=10% to 90% of 3.3V(Select 3.3V)       |      | 300  |      | μs   |
| t <sub>12</sub>              |   | V <sub>pp</sub> OUT=10% to 90% of 5.0V(Select 5V)         |      | 360  |      | μs   |
| t <sub>15</sub>              | V <sub>pp</sub> Turn-off Delay Time<br>(*Note 1,3)  | V <sub>pp</sub> OUT=3.3V to Hi-Z                          |      | 0.1  |      | μs   |
| t <sub>16</sub>              |   | V <sub>pp</sub> OUT=5V to Hi-Z                            |      | 0.1  |      | μs   |
| t <sub>13</sub>              | V <sub>pp</sub> Falling Time (*Note 3)              | V <sub>pp</sub> OUT=90% to 10% of 3.3V(Select 3.3V)       |      | 0.05 |      | μs   |
| t <sub>14</sub>              |   | V <sub>pp</sub> OUT=90% to 10% of 5.0V(Select 5V)         |      | 0.05 |      | μs   |

(\*Note1) Delay from commanding Hi-Z or 0V to beginning slope

(\*Note2) t<sub>1</sub> to t<sub>8</sub> Test Condition: R<sub>L</sub>=10Ω

(\*Note3) t<sub>9</sub> to t<sub>15</sub> Test Condition: R<sub>L</sub>=100Ω

(\*Note4) Do not apply to current limit or thermal shutdown conditions during these terms

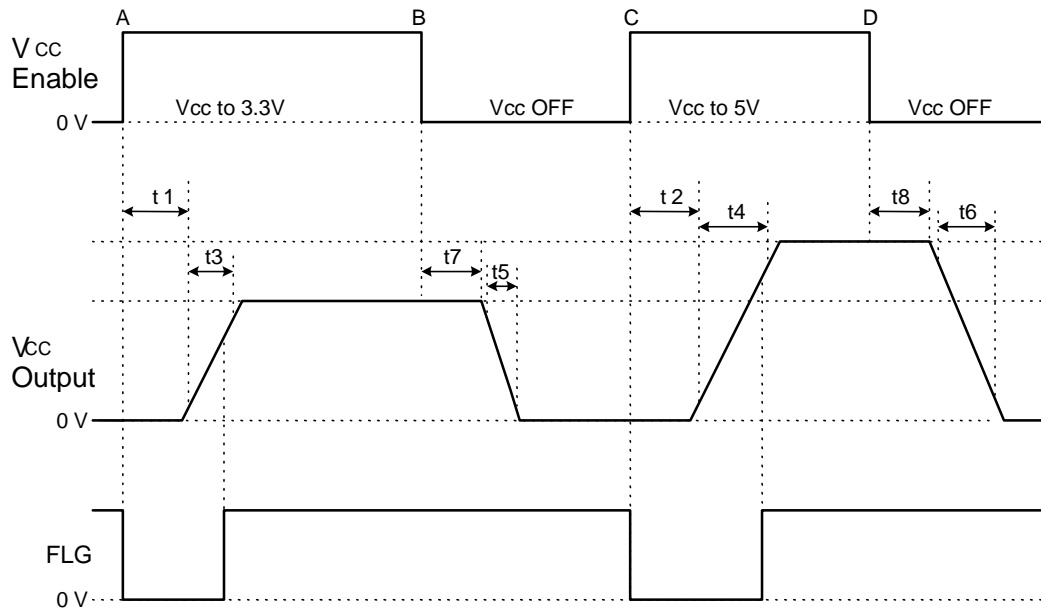

**Fig.1 R5534V V<sub>CC</sub> Timing Diagram**

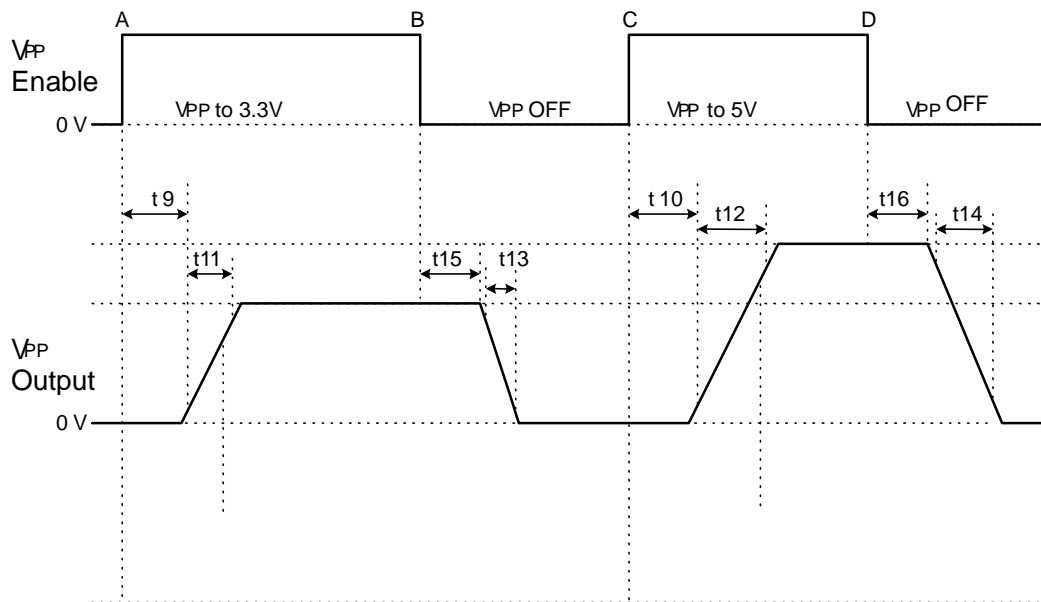

**Fig. 2 R5534V V<sub>PP</sub> Timing Diagram**

R5534V Control Logic Table

| VCC5_EN | VCC3_EN | EN1 | EN0 | Vcc OUT | Vpp OUT |
|---------|---------|-----|-----|---------|---------|
| 0       | 0       | 0   | 0   | 0V      | 0V      |
| 0       | 0       | 0   | 1   | 0V      | Hi-Z    |
| 0       | 0       | 1   | 0   | 0V      | Hi-Z    |
| 0       | 0       | 1   | 1   | 0V      | Hi-Z    |
| 0       | 1       | 0   | 0   | 5V      | 0V      |
| 0       | 1       | 0   | 1   | 5V      | 5V      |
| 0       | 1       | 1   | 0   | 5V      | Hi-Z    |
| 0       | 1       | 1   | 1   | 5V      | Hi-Z    |
| 1       | 0       | 0   | 0   | 3.3V    | 0V      |
| 1       | 0       | 0   | 1   | 3.3V    | 3.3V    |
| 1       | 0       | 1   | 0   | 3.3V    | Hi-Z    |
| 1       | 0       | 1   | 1   | 3.3V    | Hi-Z    |
| 1       | 1       | 0   | 0   | 0V      | 0V      |
| 1       | 1       | 0   | 1   | 0V      | Hi-Z    |
| 1       | 1       | 1   | 0   | 0V      | Hi-Z    |
| 1       | 1       | 1   | 1   | 0V      | Hi-Z    |

## ■ OPERATION

When the VccOUT =0V is selected, the IC switches into the sleep mode, and draws only some nano-amperes of leakage current.

Without being V<sub>CCOUT</sub>=0V, if commanded to immediately switch from 5V to 3.3V or vice versa, enhancement of the second switch begins after the first is OFF, realizing break-before-make protection.

In case that an OUT pin may be clamped to the GND, if over-current would continue, the temperature of the IC would increase drastically. If the temperature of the IC is beyond 135°C, the switch transistor turns off. Then, when the temperature of the IC decreases equal or lower than 125°C, the switch transistor turns on. Unless the abnormal situation of OUT pin is removed or turned off, the switch transistor repeats on and off.

Short over-current level is set internally in the IC. There are two types of response against over-current: Under the condition that OUT pin is short or large capacity is loaded, if the IC is enabled, the IC becomes constant current state immediately. Current level of constant current is short current limit. While the switch transistor is on, if OUT pin is short or large capacity is loaded, until the current limit circuit responds, large transient current flows. The transient current depends on the impedance between the power supply circuit, VCC5IN/VCC3IN and load capacitance. In other words, the transient current depends on the transient response characteristics of the power supply circuit, VCC5IN/VCC3IN, PCB layout, and the connector of the card. After the transient current is beyond the current limit threshold and current limit circuit responds, the IC becomes into the constant current mode, and the current level is equal to short current limit.

## ■ APPLICATION NOTES

\* VCC5IN voltage should be equal or more than VCC3IN.

\* Same name pins should be connected one another.

\* There is a parasitic diode between source and drain of the switch transistors. (Refer to the block diagram.) Therefore, even if the switch may be disabled, in case the OUT voltage is higher than VCC5IN, some current flows from OUT to VCC5IN.

\* Connect TST pin to Vcc5IN

\* Set a bypass capacitor with capacitance ranging from 0.1μF to 1.0μF between VCC5IN pin and GND pin, and between VCC3IN and GND pin each.

## TYPICAL CHARACTERISTICS

1) VCCOUT Switch Resistance vs. Temperature  
(Select VCCOUT=5V)

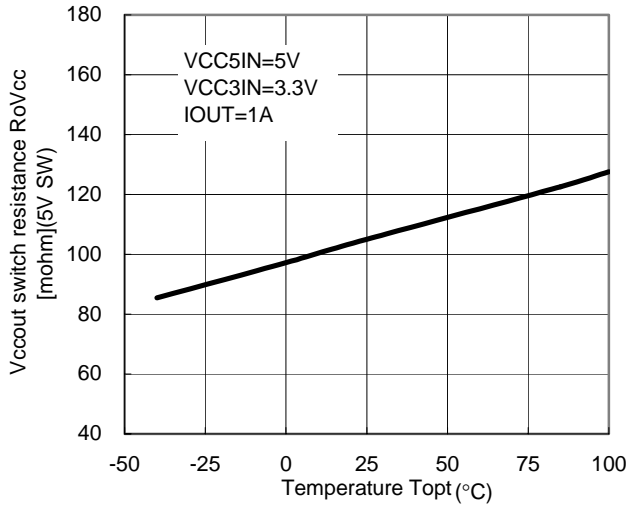

2) VCCOUT Switch Resistance vs. Temperature  
(Select VCCOUT=3.3V)

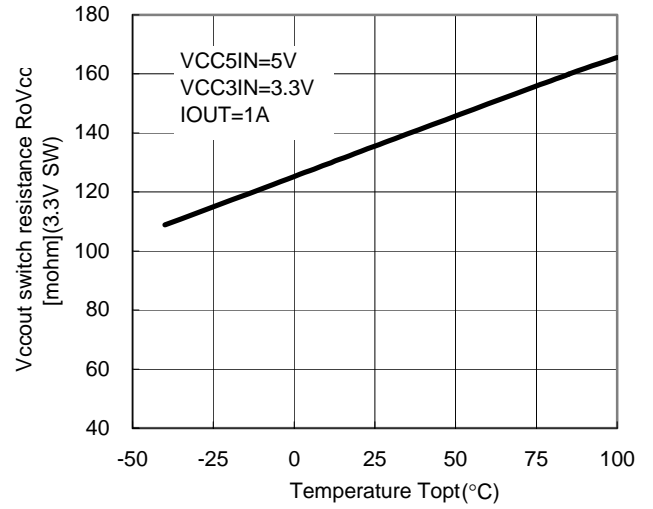

3) Vcc Turn-on Delay Time, Vcc Rising Time  
(Select VCCOUT=5V)

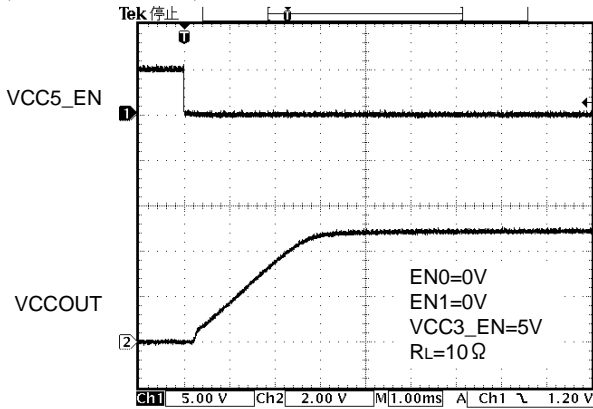

4) Vcc Turn-off Delay Time, Vcc Falling Time  
(Select VCCOUT=5V)

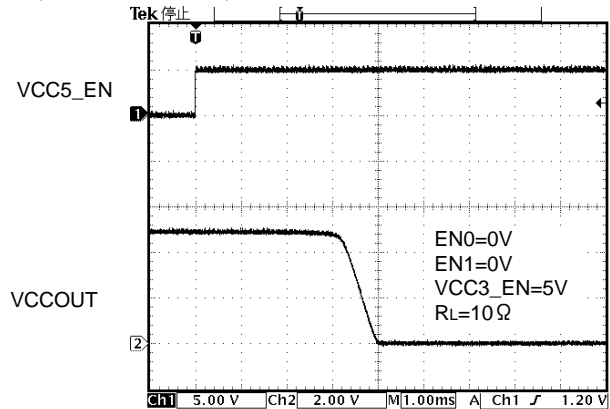

5) Vcc Turn-on Delay Time, Vcc Rising Time  
(Select VCCOUT=3.3V)

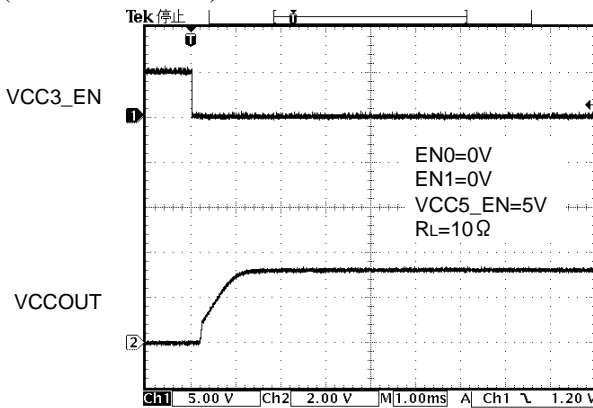

6) Vcc Turn-off Delay Time, Vcc Falling Time  
(Select VCCOUT=3.3V)

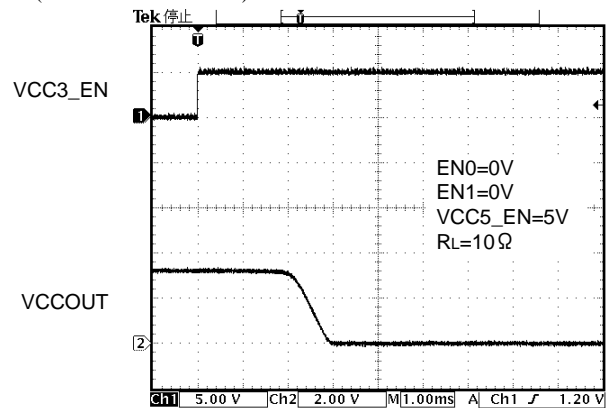

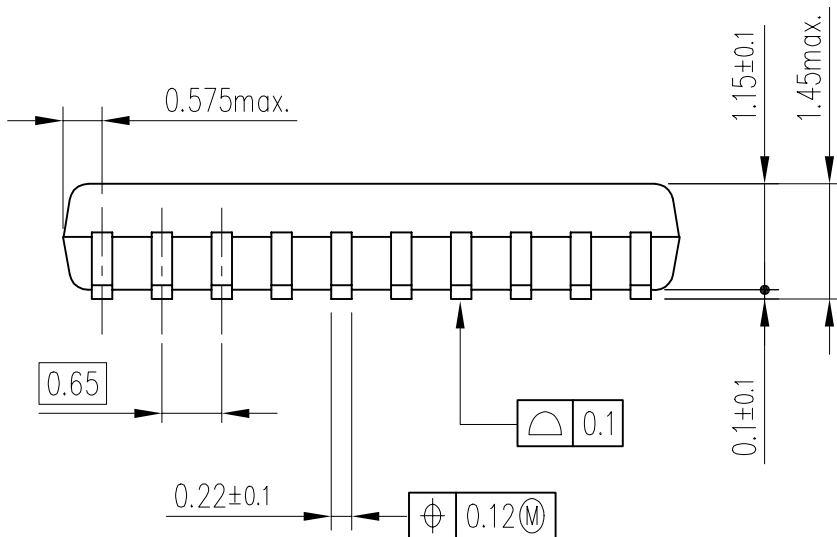
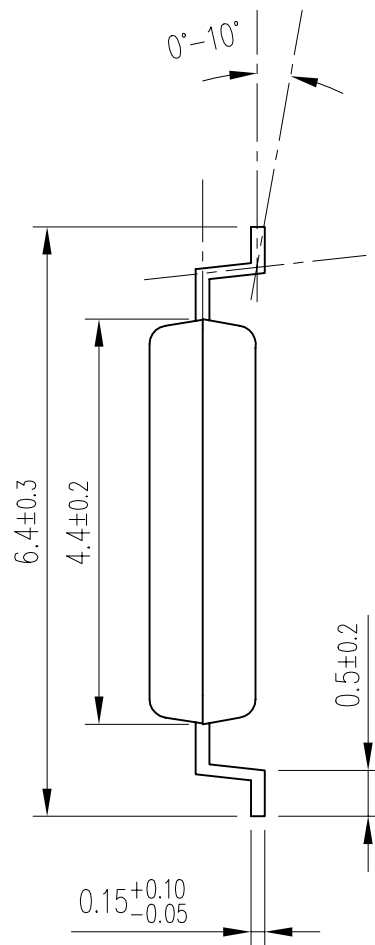
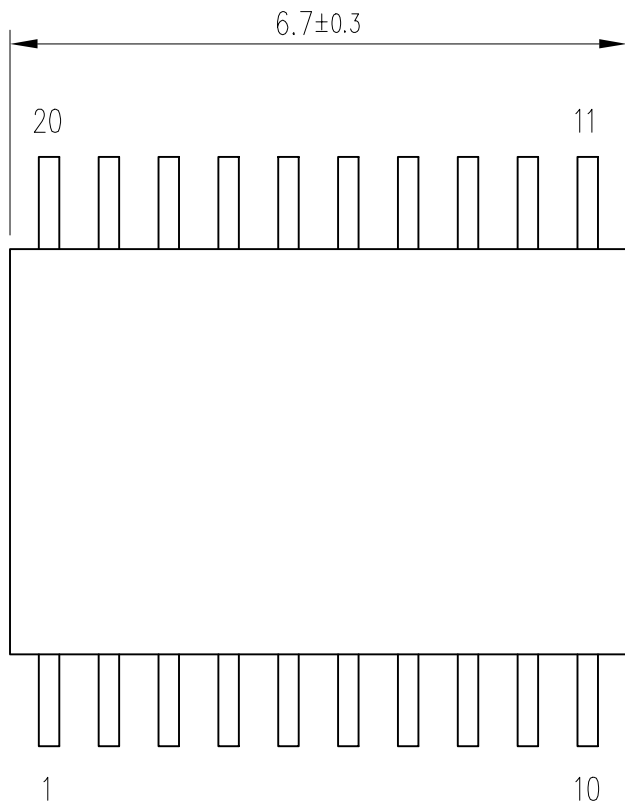

UNIT: mm

|             |                              |             |             | DIMENSIONAL TOLERANCE (±) |       |     | SPECIFIED GRADE | VISUAL GRADE |     |
|-------------|------------------------------|-------------|-------------|---------------------------|-------|-----|-----------------|--------------|-----|
|             |                              |             |             | DIMENSION X               | CLASS | 1   |                 |              | 2   |
|             |                              |             |             | X ≤ 16                    |       | 0.1 | 0.1             | 0.2          |     |
|             |                              |             |             | 16 < X ≤ 63               |       | 0.1 | 0.2             | 0.3          |     |
|             |                              |             |             | 63 < X ≤ 250              |       | 0.2 | 0.3             | 0.5          |     |
|             |                              |             |             | 250 < X ≤ 1000            |       | 0.3 | 0.5             | 0.8          |     |
|             |                              |             |             | 1000 < X ≤ 4000           |       | 0.3 | 0.5             | 0.8          |     |
|             |                              |             |             | ANGLE TOL                 |       |     |                 | SCALE        | NTS |
| DATE        | CHANGE NOTICE / DRAW UP DATE | 2003.8.19   | SIGN        | PART NAME                 |       |     |                 |              |     |
| APPROVED BY | CHECKED BY                   | DESIGNED BY | DRAWN BY    | PART NO.                  |       |     |                 |              |     |
| T.YOSHIMURA | H.GOTOH                      | Y.TANIDA    | K.SHIMOKAWA | DF-20SOP-010              |       |     |                 | A            |     |